

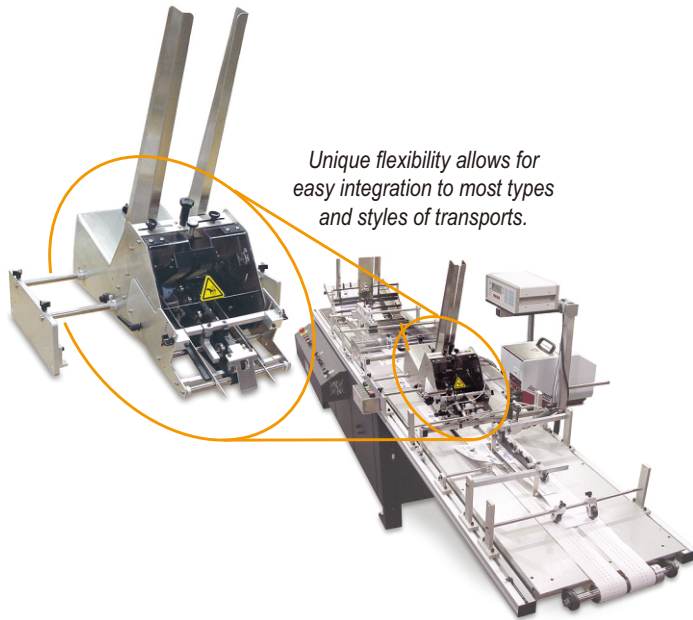

Tip-On / Affixing Model Converge 900

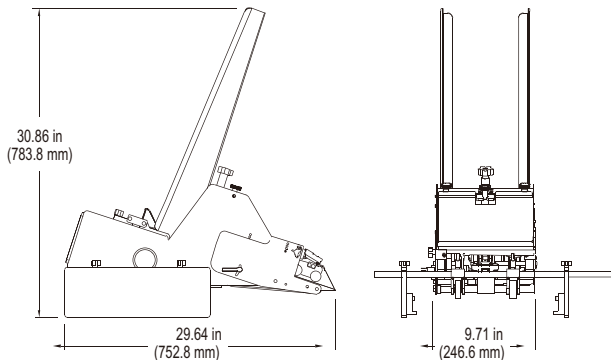

Unique flexibility allows for easy integration to most types and styles of transports.



Overview:

The Converge 900 is the most accurate, innovative high-speed product placement solution available. The Converge 900 precisely places products at high-speed onto carrier pieces traveling on a variety of transports. Singulates and dispenses the widest range of material types and sizes.

Applications:

- Gift cards onto a hanging backer
- Promotional documents onto magazines
- Folded documents onto cartons/boxes
- Embossed credit cards onto folded/unfolded paper carriers

Features:

Servo Motor and Controller

Modular Design

Placement Position Adjustment

Vacuum Assist

Articulating Discharge Section

Optional Alignment Section

Advantages:

High-speed stopping accuracy.

Can be purchased stand-alone, added to existing equipment or configured as a complete system. Use on multiple pieces of host equipment.

Placement position can be set or adjusted on the fly.

Vacuum feed capability is standard.

Height can be raised without changing tip-on position.

True fully-adjustable side registration.

Benefits:

+/- 1/16" Placement tolerance.

Low initial investment. Enables system to process largest variety of products. Utilizes existing resources.

Quickly & accurately adjust product position on the run.

No struggling with coated or slick stocks.

Increases feeder mounting options and system flexibility.

Tighter tolerances and improved product quality.

Specifications

Maximum Product Size:	7 W x 6 L in (177 x 152 mm)
Minimum Product Size:	2 W x 2.5 L in (50 x 63 mm)
Min/Max Product Thickness:	.003-.250 in (.076 x 6.35 mm)
Belt Speed:	24,000 in/min (609,600 mm/min)
Placement Tolerance:	Steady speed up to +/- 1/16 in (1.58 mm)
Electrical Requirements:	115/230vac, 10A
Air Requirements:	4-6 CFM
Weight:	60 lbs. (27.22 kg)
Warranty:	One-year limited

Streamfeeder - Asia : PT. Cakrawala Mega Engineering, Tel : +62 21 2952 6490, +62 812 921 6168, Email : sales@cakrawalamega.com

