

Batch Counting Series Streamfeeder - Ultra High-Speed XT-1200 Paddle Wheel Dropper System

Overview

The fastest batch counting feeder/dropper in the marketplace! Designed for ultra-high-speed batch counting of card and envelope type products, the XT-1200 provides a universal solution for packaging operations requiring greater productivity through automation. The heavy-duty, robust design is perfect for lines that run 24/7. It can accommodate a wide variety of product types including coupons, greeting cards, advertising cards, envelopes, folded brochures, booklets, and more.

Feed a wide variety of flat and multi-thickness products into shrink wrappers, poly baggers, banders, collators, case packers, boxes, and more.

Standard Features

Long-lasting natural gum rubber feed belt vacuum assist ready • Independent side guide adjust • System Interface I/O package • Patented powered separating technology • Tool-less setup and changeovers • Easy-adjust dropper • Self-adjusting discharge hold down • Variable speed control • Heavy-duty adjustable stand with casters • Batch counting up to 99 pieces • Timeout stop, high-performance photo-sensors

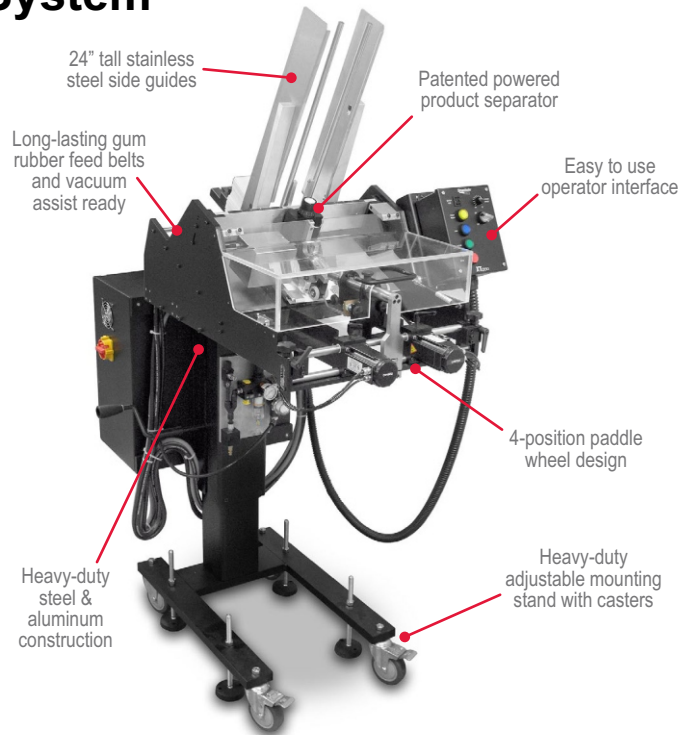

Applications *(ask us about your application)*

Shrink Wrappers	Flow Wrappers	Banders
Poly-baggers	Cartoners	Collators
Case Packers	Order Fulfillment	

Products *(ask us about your products)*

Swatch Cards	Cardstock	Folded Brochures
Warranty Cards	Envelopes	Coupons
Greeting Cards	BRE's	and more...

Specifications

Maximum Product Size	9 W x 7 L in (229 x 178 mm)
Minimum Product Size	4.5 W x 4 L in (114 x 102 mm)
Min/Max Product Thickness	.003 - .500 in (.076 - 12.7 mm)
Belt Speed	13800 in/min (350 m/min)
Productivity	Example: 200 batches/min, 6 count, 5 x 5 in (127 mm)
Batch Size	1-99
Utilities	115/230vac, 50/60Hz, 3.15A
Air	5 CFM
Weight	260 lbs. (118 kg)
Warranty	One year limited

Other sizes and thickness capabilities available. Contact us for your application.

Streamfeeder - Asia : PT. Cakrawala Mega Engineering, Tel : +62 21 2952 6490, +62 812 921 6168, Email : sales@cakrawalamega.com

