

Reliant 2600/2700

Universal Friction Feeders[®]

Product Guide

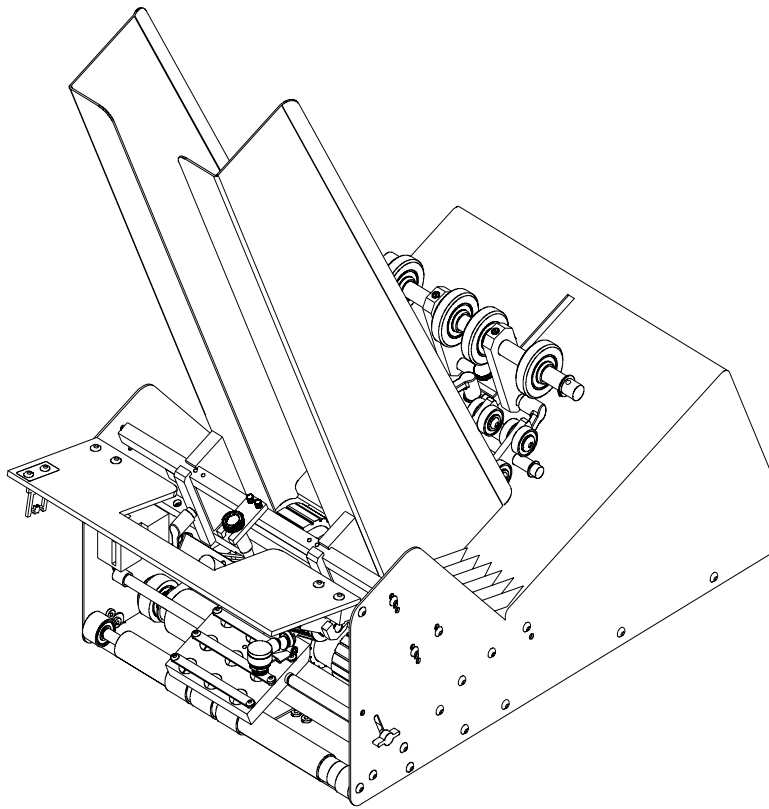

Streamfeeder[®]

First Edition (November, 2001)

Part Number: 00900368

© 2002 Streamfeeder, LLC. All rights reserved.

No part of this publication may be reproduced, photocopied, stored on a retrieval system, or transmitted without the express written consent of Streamfeeder, LLC.

Streamfeeder, LLC
103 Osborne Road
Minneapolis, MN 55432-3120 USA

TEL: 763.502.0000

FAX: 763.502.0100

E-MAIL: service@streamfeeder.com

WEB: www.streamfeeder.com

Printed in the USA.

Contents

	Before You Begin	viii
	Who Should Read This Manual	viii
	How This Manual is Organized	viii
	Message Conventions	ix
	Safety	x
	Danger	x
	Warnings	x
	Cautions	xi
	Labeling	xii
	Electrical Noise	xii
	Safety Listings and Certifications	xii
	Specifications	xiii
Section 1:	About the Machine	1
	Features	1
	Main Assemblies	1
	Control Panel Components	3
Section 2:	Installing the Machine	5
	2A: Vacuum Base Installation	5
	Step 1: Repositioning Front Side Guides	6
	Step 2: Removing Back Jogging Plate/Back Hopper Guide	6
	Step 3: Raising Hopping Rollers	7
	Step 4: Disabling the Shuttle	7
	Step 5: Initial Positioning of Feeder	8
	Step 6: Providing AC Power to Feeder	8
	Step 7: Connecting External Run Input	9
	Step 8: Checking Material Discharge from Feeder	9
	Step 9: Miscellaneous Feeder Adjustments	10

2B: Inserter Installation	11
Step 1: Removing Rear Guide Assembly	11
Step 2: Removing T-Plate	12
Step 3: Repositioning Separator Foot	12
Step 4: Removing Suction Cup and Closing Off Vacuum Hose	13
Step 5: Repositioning Insert Guide Tabs	14
Step 5A: Optional Step – Installing Insert Plate Guide	15
Step 6: Installing Feeder Hold-Down Spring Assemblies	16
Step 7: Aligning Feeder with Insert Station	17
Step 8: Securing Feeder to Inserter	17
Step 9: Installing Support Pedestal	18
Step 10: Providing AC Power to Feeder	18
Step 11: Initial Feeder Photo Sensor Positioning	19
2C: Bryce 16K Ink Jet Printer Base Installation	20
Step 1: Positioning the Feeder and the Bryce 16K Base	20
Step 2: Wiring the Feeder to the Bryce 16K Base	20
Step 3: Providing AC Power to Feeder	21

Section 3: Preparing for Operation 23

Step 1: Gate Assembly Adjustment	24
Changing from Factory Set High-Tension to Low-Tension	25
Step 2: Side Guides Setting	27
Step 3: Back Wedge Adjustment	29
Step 4: Top Roller Hold-Down Assembly Setting	31
Step 4A: Optional Step – Final Photo Sensor Adjustment (Inserter Applications Only)	32
Step 5: Verifying Proper Installation	34
Review of Installation	34
Manual Test to Verify (for All Applications)	35

Section 4: How to Operate 37

Sequence of Operation	37
Step 1: Loading Material in the Hopper	37
Step 2: Determining Stack Height	38
Step 3: Powering On Feeder	38
Step 4: Setting/Adjusting Speed	39
Step 5: Running Test Cycles	39
Step 6: Final Check	40
Clearing a Jam	40
Shutdown	40

Section 5:	Operational Troubleshooting	41
	No AC Power to Feeder	41
	Feeding Doubles	41
	Continuous Feeding (“Presentation Mode”).....	41
	Feeder Times Out While in Continuous Mode; Continuous Alarm Sound	41
	Feed Belts Are Operating, But Material Not Feeding	41
	Feed Belts Not Operating; Continuous Alarm Sound	42
	Feed Belts Not Operating Intermittent Alarm Sound	42
	Feed Belt(s) Not Tracking on Rollers	42
	Jamming Occurs During Operation	42
	Material Skewing	42
	Material Too Far from Gripper Jaw (Inserter Applications Only)	42
	Material Too Deep in Gripper Jaw (Inserter Applications Only)	42
Section 6:	Inspection and Care	43
	Visual Inspection	43
	Checking for Feed and Discharge Belt Wear	43
	Checking for Timing and Drive Belt Wear	43
	Ensuring Proper Feed and Discharge Belt Tracking	44
	Ensuring Proper Timing and Drive Belt Tracking	44
	Checking for Gate Assembly Wear	45
	Advancing O-Ring Gate: Adjusting Worn Rings	46
	Standard O-Ring Gate: Adjusting Worn Rings	46
	Replacing Worn Angled Wedge	46
	Preventive Care.....	47
	Cleaning Feed and Discharge Belts	47
	Cleaning Gate Assembly	48
	Cleaning Photo Sensor (Inserter Applications Only)	49
Section 7:	Additional Wedges	51
	Load Compensating	51
	Articulating Roller	52
	Extended Narrow	52
	Combination Triangle and Low-Profile	53
	Separate Triangle and Low-Profile	53
	Separate Articulating Roller and Low-Profile	54

Section 8:	Mechanical Components	55
	Triangle Wedge	56
	Single S Wedge	58
	2 Knob Gate Plate	60
	1 Knob Solid Gate Plate	62
	Standard O-Ring Gate with Horizon Adjust and Cover	64
	Advancing O-Ring Gate with Horizon Adjust and Cover	66
	Grooved Gum Carriage (2600)	68
	Grooved Gum Carriage (2700)	70
	Hold Down	72
	Electrical Components	74
	Base Features 1	76
	Base Features 2	78
	Support Stand	80
	Standard Material Hold Down	81
Section 9:	Electrical Components	83
	Dual Mode without External Run Option	83
	Dual Mode with External Run Dry Contact	84
	Dual Mode with External Run 3-28VDC	85
	Dual Mode with Powered External Run	86
	Continuous Mode without External Run Option	88
	Continuous Mode with External Run Dry Contact	90
	Continuous Mode with External Run 3-28VDC	91
	Continuous Mode with Powered External Run	92
	Presentation Mode Electrical Wiring	94
	Emergency Stop Option	96
	Reliant 2600/2700 Bryce	98
	Reliant 2600/2700 Datatech	100
	Reliant 2700 w/RSI Interface	102
	Power Entry Module	104
	Transformer	105
	DC Stepping Motor	106
	Unipolar DC Stepping Motor Drive Board	107
	Dip Switch Settings Continuous Mode Only	108

Section 10: Technical Troubleshooting 111

General Troubleshooting Terms 111

Quick-Look Troubleshooting 113

 No Power to Feeder When Power Switch is Turned On 113

 Fuses Blow on Power Up 113

 Decreased Power Experienced After Fuse is Replaced 114

 Decreased Power Experienced After Drive Board is Replaced 114

 Motor Does Not Run, is Noisy, Makes a "Growling" Sound or
 Runs in Reverse 114

 Drive Board Red LED Illuminated 115

 Testing Stepper Motor Drive Board Output Pins 115

 Fan Does Not Operate/Testing DC Power Supply 116

 CPU Board "Heartbeat" Pulse Not Present 116

 On/Off Beeping Sound is Heard 117

 Steady Beep is Heard 117

 Testing the External Run Dry Contact Input 119

 Testing the External Run Input 3-28 Volts DC 119

 Testing the Powered External Run Input 120

 Testing the Fault Output Connector 121

 Testing Motors 121

 Testing the Transformer 122

Warranty

Before You Begin

Welcome to Streamfeeder. This manual was included with your new Streamfeeder Reliant 2600/2700 Universal Friction Feeder. It provides all the information you need to efficiently operate and maintain the product.

Who Should Read This Manual

This manual is primarily intended for operators who will be using the Reliant 2600/2700 Universal Friction Feeder in their day-to-day operations. *Please read it thoroughly before you operate the machine.*

Qualified technicians should also be familiar with the information in this manual.

This manual is divided into the following main areas:

How This Manual Is Organized

- **Safety:** *This section is at the front of this manual for good reason. It covers all safety issues that you should be familiar with before you go any further with adjustments, power-up, or operation.*
- **Section 1, About the Machine:** *Introduces you to the feeder. It provides a complete description of all controls, connectors, and sensors.*
- **Section 2, Installing the Machine:** *Provides you with simple step-by-step instructions to properly install and align a Reliant 2600/2700 with a vacuum base, gripper arm inserter, or ink jet printer.*
- **Section 3, Preparing for Operation:** *Includes all adjustments you should make before attempting to do a power-up and successfully run material through the machine.*
- **Section 4, How to Operate:** *Walks you through the basic steps needed to run the machine — from power-up to shutdown.*
- **Section 5, Operational Troubleshooting:** *Gives you the basic diagnostic information you need to quickly and accurately solve problems to minimize downtime.*
- **Section 6, Inspection and Care:** *Covers all of the steps you can take to keep your feeder running properly to minimize downtime and increase longevity of parts.*
- **Section 7, Additional Wedges:** *Provides information about setting up various wedges which are optional with the Reliant 2600/2700.*
- **Sections 8 and 9, Mechanical Components and Electrical Components:** *These sections contain extensive detailed information for qualified technicians responsible for servicing and maintaining the Reliant 2600/2700.*
- **Section 10, Technical Troubleshooting:** *Gives you the basic diagnostic information you need to quickly and accurately solve problems to minimize downtime.*



The information in Sections 5 and 10 are designed to be a quick and easy method for the operator to minimize downtime. Streamfeeder does not recommend opening the feeder compartment, or performing any part replacement based on the information given in this manual. For more detailed information, please consult with a qualified technician.

Message Conventions

Here are eight types of messages that appear in this manual which help emphasize information of particular interest:



DANGER signifies an operator action or specific equipment area that can result in serious injury or death if proper precautions are not taken.



WARNING signifies an operator action or specific equipment area that can result in personal injury if proper precautions are not taken.



CAUTION signifies an operator action or specific equipment area that can result in equipment damage if proper precautions are not taken.



ELECTRICAL DANGER signifies an operator action or specific equipment area that can result in personal injury or death from an electrical hazard if proper precautions are not taken.



TIP signifies information that is provided to help the operator minimize problems in the operation of the machine.



NOTE provides useful additional information that the operator should be aware of to perform a certain task.



CHECK signifies an action that should be reviewed by the operator before proceeding.



IMPORTANT signifies alerting the operator to actions that can potentially lead to operational problems or equipment damage if instructions are not followed properly.

Safety

Make sure you thoroughly read this Section until you become familiar with all of the safety issues relating to the safe operation of this machine.

Please read all of the Warnings that follow to avoid possible injury. Although Streamfeeder has made every effort to incorporate safety features in the design of this machine, there are residual risks that do exist that an operator should be aware of to prevent personal injury.

Please read all of the Cautions that follow to prevent damage to the machine. The Reliant 2600/2700 Universal Friction Feeder is built with the highest quality materials. However, damage can occur if the machine is not operated and cared for within design guidelines as recommended by Streamfeeder.

Danger



- **Equipment interior contains incoming 115- or 230-VAC electrical power. Bodily contact with these high voltages can cause electrocution, which can result in serious injury or death.**

Warnings



- **When operating the feeder, always make sure the discharge safety shield is in the closed position (covering the discharge belts and rollers).** Failure to do so may expose your hands or fingers to moving parts which can cause serious injury.
- **When performing service or maintenance on the feeder, always lift the discharge safety shield to disengage the safety interlock, turn Off the main power switch, and disconnect the feeder from the electrical power source.** Failure to do so may expose you to dangerous high voltage or moving parts which can cause serious injury.
- **When performing initial adjustments prior to operation, always make sure you lift the discharge safety shield to disengage the safety interlock, turn Off the main power switch, and disconnect the feeder from the electrical power source.** Failure to do so may expose you to a potential start-up and moving parts which can cause serious injury.
- **Make sure you always plug the machine into a 3-prong, properly grounded and fused electrical power source.** Never remove or disable the grounding lug at the outlet. Failure to follow these warnings may expose you to dangerous high voltage which can cause serious injury.

Warnings (cont.)



- **Do not attempt to make any adjustments while the machine is running.** Failure to follow this warning may expose you to moving parts which can cause serious injury.
- **Never attempt to clear a jam from the machine until you turn Off the main power switch and disconnect the machine from the electrical power source.** Failure to do so may expose you to a potential start-up and moving parts which can cause serious injury.
- **Do not attempt to gain access to the inside of the feeder.** Refer all questions or problems to a qualified technician.

Cautions



- **When the machine is not in use, avoid stacking or storing materials on the carriage assembly to prevent damage to the belts.**
- **When replacing fuses, always use the exact type supplied with the machine as shipped from the factory. IMPORTANT: Always make sure power module is replaced exactly as removed. Failure to follow this caution can result in damaged electrical parts.**
- **When performing routine cleaning of parts, only use those methods and cleaning solvents (isopropyl alcohol) which are specified by Streamfeeder.** Failure to do so may cause unpredictable results and can cause damage to machine parts. See Section 6, Inspection and Care, for recommendations.
- **Do not attempt to use the machine for any other purpose other than what was recommended by Streamfeeder.** Failure to follow this caution may cause unpredictable performance, and/or can cause damage to machine parts.
- **Avoid leaving any loose cabling near any moving parts.** Failure to follow this caution may result in damage to machine parts.
- **Avoid any type of direct impact to the sensor and extension assembly.** Failure to follow this caution can cause damage to the photo sensor or extension.
- **Do not apply lubricants to any part of the machine.**
- **Do not attempt to gain access to the inside of the feeder. Do not attempt to remove and replace parts.** Refer all questions or problems to a qualified technician.

Labeling

Streamfeeder has affixed safety labels to those areas of the Reliant 2600/2700 Universal Friction Feeder where potential operator hazards do exist (such as moving belts or rollers). Shown below are label examples, along with their respective locations.

**Feed Belt
Guards**



**Discharge
Safety Shield**



Electrical Noise

The air contains electromagnetic interference (EMI) fields and radio frequency interference (RFI), also known as “electrical noise”. Usually this noise is small enough in size (amplitude) to not be a problem. If intense enough, however, it can cause problems for other electrical equipment.

Streamfeeder has designed the feeder with noise immunity in mind. Even the sensors provided with the machine have a certain amount of noise immunity built-in. However, in extremely noisy environments, these design considerations are not necessarily immune to electrical noise and therefore, operational problems can occur. *If you suspect any such electrical noise problems, please report it to a qualified technician.*

Safety Listings and Certifications



This symbol on the back panel means the product is in compliance with the following standards under the provisions of the Machinery Directive 89/392/EEC and the amendments 91/368/EEC, 93/44/EEC and 93/68/EEC, and the EMC Directive 89/336/EEC.

Specifications

Maximum Material Size:	
2600:	10 3/4 in. W x 14 in. L (27.31 cm x 35.56 cm)
2700:	11 3/4 in. W x 14 in. L (29.85 cm x 35.56 cm)
Minimum Material Size:	3 3/4 in. W x 2 1/2 in. L (9.53 cm x 6.35 cm)
<i>Optional:</i>	2 in. W x 2 1/2 in. L (5.08 cm x 6.35 mm)
Thickness Range:	.003 in. to .5 in. (.076 mm to 12.7 mm)
<i>Optional:</i>	.003 in. to 1 in. (.076 mm to 25.4 mm)
Printing/Labeling Productivity:	Up to 144,000/hour (business cards)
Inserter Productivity:	10,000/hour (product dependent)
Belt Speed:	9,000 in./minute (228.59 m/minute)
Hopper Capacity:	24 in. (60.96 cm)
Drive:	Stepper motor
Power Input:	115VAC/230VAC 50/60 Hz 3 amps
Sensor:	Diffuse reflective
Switches & Controls:	Power On/Off; Variable speed control; Reset; Fault indicator
Construction:	Powder coated cold-rolled steel enclosure; aluminum base plate
Overall Dimensions:	
2600:	21 in. L (53.34 cm) 12 1/4 in. W (31.16 cm) 26 1/2 in. H (67.31 cm)
2700:	21 in. L (53.34 cm) 13 1/4 in. W (33.66 cm) 26 1/2 in. H (67.31 cm)
Weight:	
2600:	57 lb. (25.79 kg)
2700:	59 lb. (26.69 kg)
Certifications:	CE
Warranty:	Two-year limited warranty

1 About the Machine

Features



- *Feeders can be configured three ways: presentation mode only, continuous mode only, or dual mode (both).*
- *Presentation mode feeders can be used for inserter applications.*
- *Continuous mode feeders can be used for vacuum, non-vacuum base applications.*
- *Dual mode feeders can be used for either presentation or continuous mode applications.*
- *For purposes of illustration, a dual-mode feeder is shown in all drawings of this manual.*

The Reliant 2600/2700 Universal Friction Feeder is designed for reliability, flexibility, and ease of use with a variety of host systems. Included are such applications as vacuum and non-vacuum bases, inserters, and ink jet printer bases.

All parts required for setup, loading, feeding, sensing and easy operator control are combined into one compact unit.

Review the *main assemblies* in Figure 1-1 to become familiar with names and locations of feeder parts and adjustments. This will help prepare you for initial setup. Descriptions are found in Table 1-1.

Review the *control panel components* in Figure 1-2 to become familiar with names and locations of specific connectors, switches, and controls. This will help prepare you for installation and operation. Descriptions are found in Table 1-2.

Main Assemblies

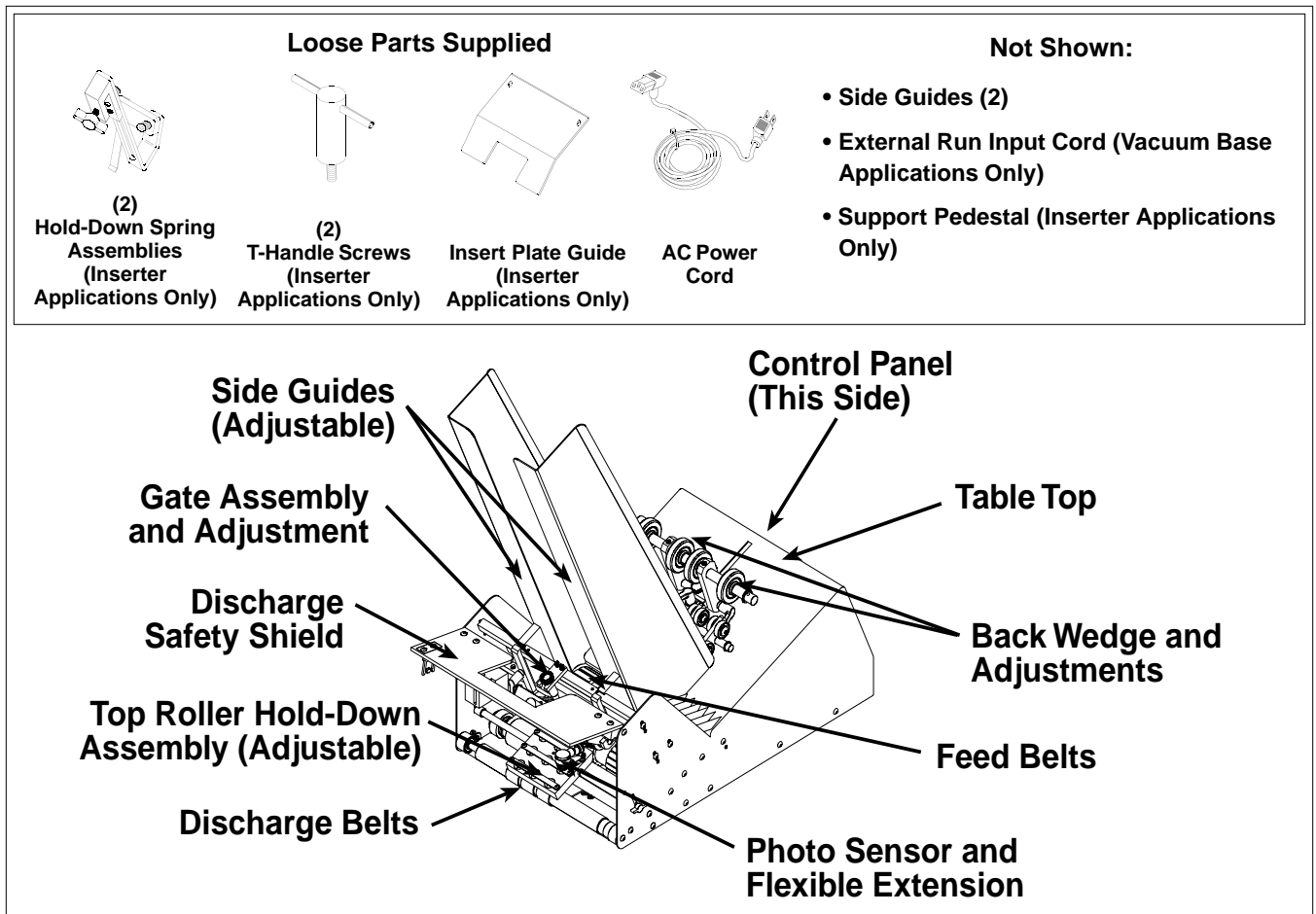

Figure 1-1. Main Assemblies of the Reliant 2600/2700 Universal Friction Feeder

Table 1-1. Main Assemblies Feature Descriptions

Feature	Description
Gate assembly and adjustment	Mounted on a gate bracket assembly above the feed belts, this device provides a curvature to help preshingle stacked material. When properly adjusted, a clearance is created to help singulate and feed material. <i>(Note: For multiple page material, a 1 to 1.5 maximum thickness is typical.)</i>
Table top	Used to support the back wedge.
Side guides (adjustable)	Holds a stack of material to be fed and helps keep it straight for proper entry through the gate assembly area. Single adjustment knob allows you to move side guides together or apart for different size material. Can be positioned equally or offset. <i>(Note: Dual-knob design also available.)</i>
Back wedge and adjustment	Lifts the material to keep it off the table top, reduces excessive contact with the feed belts, and helps push the material against the curvature of the gate assembly. To achieve proper lift, adjustment wing-nuts and locking levers allow you to slide the wedge to various positions and angles.
Photo sensor and flexible extension	<i>(Note: Inserter applications only.)</i> Also called a <i>sheet-detect</i> photo sensor, it “looks” for the leading edge of the material to stop the feeder. For optimum setting, a flexible extension allows you to adjust for distance and perpendicular angle to material.
Feed belts and discharge belts	<i>Feed belts:</i> Provides the friction and motion necessary to pull individual material from the bottom of the stack and through the gate assembly area. <i>Discharge belts:</i> Combined with the top roller hold-down assembly, provides the friction and motion necessary to pull material away from the gate assembly area.
Top roller hold-down assy (adjustable)	A block of small rollers mounted on a movable shaft. Used to gently force the material down on the discharge belts so that it can be controlled after it exits the gate assembly area. To achieve proper downward pressure, T-nuts allow you to loosen the shaft to adjust block up or down.
Control panel	All connectors and switches for sensor, interface, and AC power are located here. For descriptions, see Figure 1-2 and Table 1-2.
AC power cord, 8 ft. (2.44 m)	IEC320 removal three-prong. Shipped loose.
Discharge safety shield	Provides residual risk protection to operator when feeder is running. Built-in interlock switch stops the feeder when opened.
Support pedestal	<i>(Note: Inserter applications only.)</i> Supports part of feeder that extends over the inserter’s back deck plate. Includes built-in height adjustment.
Loose Parts	
External run input (optional)	<i>(Note: Vacuum base and Bryce 16K base applications only.)</i> This two-wire interface cable allows the feeder to be turned On or Off with the host base.
Hold-down spring assemblies	<i>(Note: Inserter applications only.)</i> As a piece of material exits the feeder gate assembly area, these two hold-down spring assemblies help keep it aligned and in proper position for the gripper jaw. Mounted on inserter.
T-handle screws	<i>(Note: Inserter applications only.)</i> These two hand-tightening screws secure the feeder to the inserter back deck plate. Fastened to underside of feeder.
Insert plate guide	<i>(Note: Inserter applications only.)</i> This plate is supplied with your feeder and is to be mounted on the inserter’s back deck plate (if required).

Control Panel Components

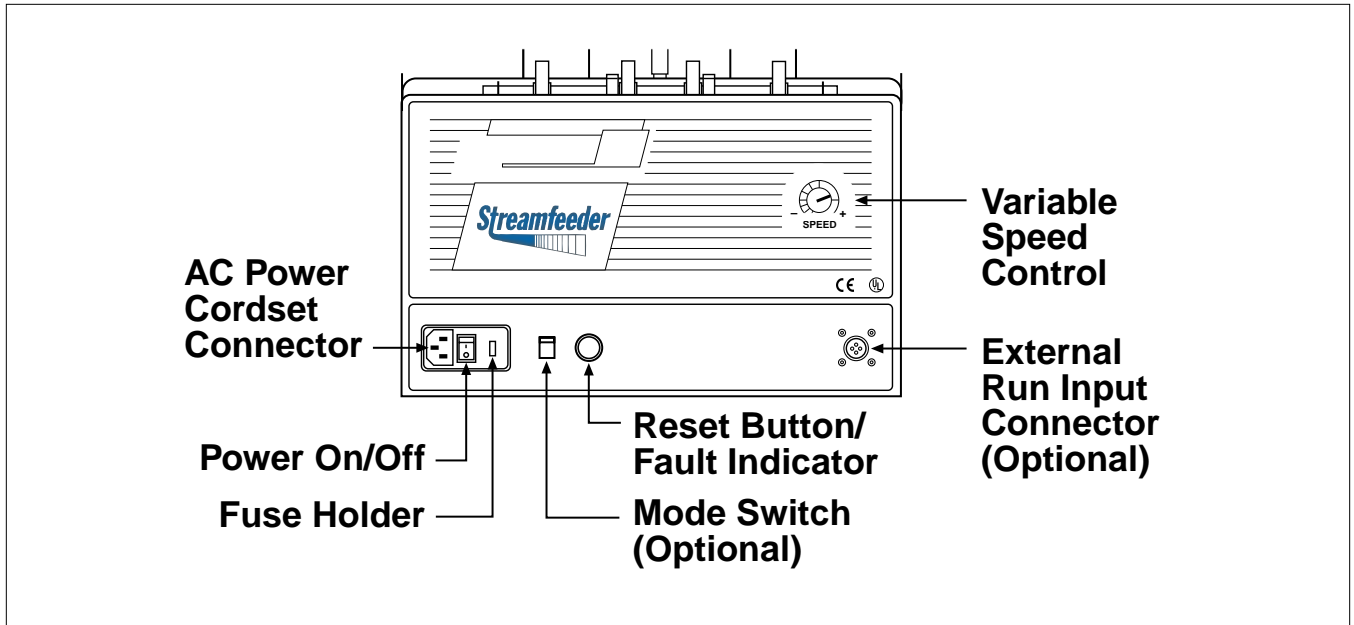

Figure 1-2. Control Panel Components

Table 1-2. Control Panel Feature Descriptions

Feature	Description
AC power cordset connector	Cordset plugs into this IEC320 connector to provide feeder with power from a grounded/fused outlet. Switchable for either 115- or 230-VAC.
External run input connector (optional)	<i>(Note: Vacuum base only.)</i> This 2-pin connector (labeled External Run Input) is used to carry start/stop signals from a vacuum or non-vacuum base to the feeder.
Power On/Off	Toggles AC power On or Off.
Fuse holder	Contains two replaceable 3-Amp, 5-mm time delay fuses. <i>IMPORTANT: Always make sure power module is replaced exactly as removed. Failure to follow this caution can result in damaged electrical parts.</i>
Reset button/fault indicator	Labeled Reset , the primary purpose of this pushbutton switch/indicator is to reset the feeder after: 1) a “time-out” occurs or, 2) the discharge safety shield is opened. “Time-outs” occur: 1) during a misfeed or, 2) when the hopper runs out of material. Built-in indicator illuminates and audible alarm sounds: 1) <i>steady</i> during a time-out condition; 2) <i>flashing</i> light/intermittent alarm during an “open” discharge safety shield.
Mode switch (dual mode only)	This slide switch (labeled Continuous/Presentation) allows you to use the feeder for either inserter applications (using “presentation mode”) or vacuum, non-vacuum base applications (using “continuous mode”). <i>Note: Continuous mode feeders may be configured with a switch that is labeled Continuous/Ext. Run.</i>
Variable speed control	This dial switch (labeled Speed) allows the feeder speed to be synchronized with an inserter, vacuum or non-vacuum base. Turning counterclockwise decreases speed; clockwise increases speed.

2 Installing the Machine



When performing initial installation, always make sure you turn Off the main power switch and disconnect all equipment from the electrical power source. Failure to do so can expose you to a potential startup and moving parts which can cause serious injury.

Do not attempt feeder installation while the feeder and machine of application are running. Failure to do so can expose you to moving parts which can cause serious injury. Do not wear loose clothing when operating the feeder.

Avoid turning on the feeder or making initial adjustments until all parts are secured. Failure to do so can cause damage to equipment.

This section provides information on how to install the Reliant 2600/2700 Universal Friction Feeder in the following application environments:

- Vacuum base installation (2A)
- Inserter installation (2B)
- Bryce 16K ink jet printer base installation (2C)

Information for a particular application typically includes procedures for basic parts removal, feeder mounting and alignment, and cable connections for power and control interface. *Information that relates to specific adjustments you must make to feeder prior to startup and operation is found in Section 3, Preparing for Operation.*

2A: Vacuum Base Installation

Installation of the Reliant 2600/2700 Universal Friction Feeder with “continuous mode” or “dual mode” configurations onto various types of vacuum and non-vacuum bases is a relatively simple procedure. Several minor modifications to the vacuum base are required prior to mounting, wiring, and aligning the feeder.

To install the feeder onto a vacuum base, perform the following steps:

- 1: Repositioning front side guides
- 2: Removing back jogging plate/back hopper guide
- 3: Raising hopping rollers
- 4: Disabling the shuttle
- 5: Initial positioning of feeder
- 6: Providing AC power to feeder
- 7: Connecting external run input
- 8: Checking material discharge from feeder
- 9: Miscellaneous feeder adjustments

STEP 1: Repositioning Front Side Guides

1. Loosen locking knobs at both side guides (Figure 2-1).
2. Slide each side guide to the outermost position. Do not lock in place.

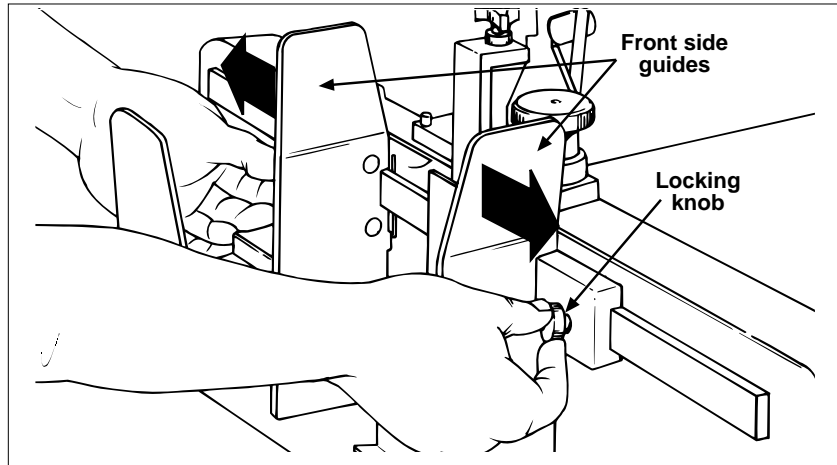

Figure 2-1. Front Side Guides Being Repositioned

STEP 2: Removing Back Jogging Plate/Back Hopper Guide

1. Loosen each of the setscrews at the two shaft housing assemblies A and B (Figure 2-2).
2. Slide shaft end closest to the vacuum base gate out of housing A (with jogging plate/hopper guides still attached). Slide shaft back far enough on housing B to allow removal of jogging plate/hopper guides.
3. Loosen locking knob and slide jogging plate/back hopper guide off of shaft and away from the surface of the vacuum base.
4. Return shaft end to housing B. Lock setscrews in both housing assemblies.

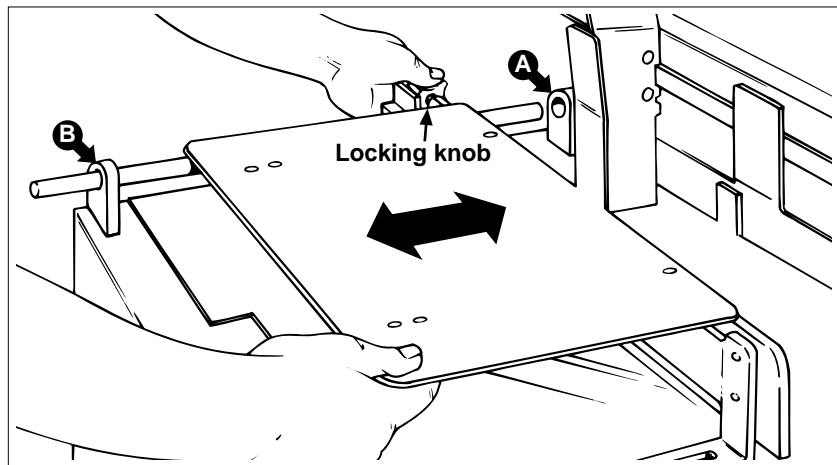

Figure 2-2. Back Jogging Plate/Back Hopper Guide Removal

STEP 3: Raising Hopping Rollers

NOTE

If additional control of material is required during feeding, you may choose to keep the base's hopping roller assembly in the down (or normal) position.

1. Locate the gate adjustment knobs (Figure 2-3) and turn completely in a clockwise direction to raise hopping rollers.
2. Locate the vertical adjustment lever on the hopping rollers assembly and push down all the way. This will raise the feed rollers to highest vertical position possible, making for maximum clearance.

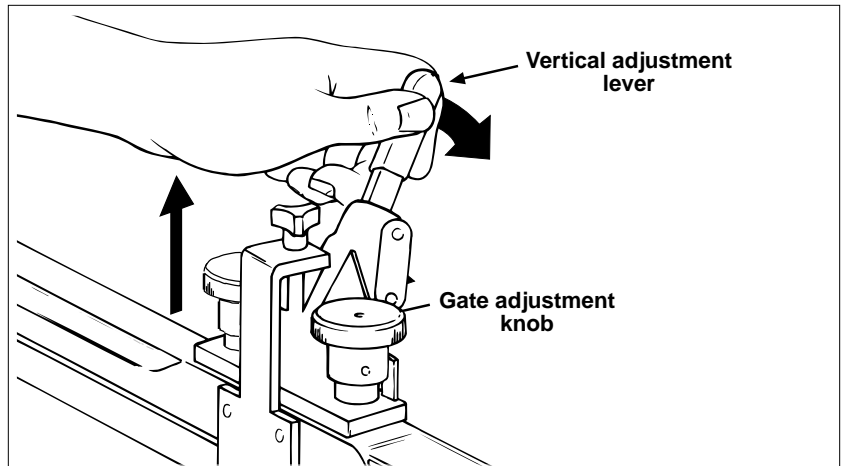

Figure 2-3. Using the Adjustments to Raise Hopping Rollers

STEP 4: Disabling the Shuttle



To prevent any accidental startup of shuttle motor and to eliminate the hazard of moving parts, you can prevent accidental startup by either disconnecting vacuum base from AC power at the outlet, or you can remove the internal AC power fuse (located behind the access door of the vacuum base).

1. Remove side access panel from vacuum base enclosure.
2. Locate the reciprocating arm and reciprocating block directly beneath the underside of shuttle (Figure 2-4).
3. Using a box wrench, remove the hex-head rod end bearing bolt holding the reciprocating arm to the reciprocating block.
4. Once the bearing bolt is removed, the reciprocating arm is effectively disconnected. As the shaft is connected to the shuttle base plate on the other end, simply allow the shaft to hang in-position, with no further disassembly.
5. Make sure the base plate of shuttle is all the way forward (toward the vacuum base gate).

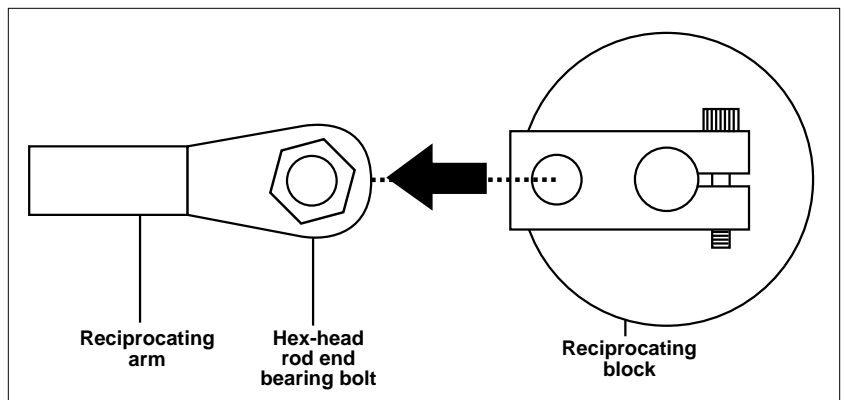

Figure 2-4. Disabling the Shuttle from Inside the Access Panel

STEP 5: Initial Positioning of Feeder

1. Lift the feeder onto the top plate of the vacuum base and slide forward toward the vacuum base gate.
2. Center the feeder between the two side guides as you position the feeder fully forward. To verify centering, sight down the center of the feeder gate, making sure it is in-line with the vacuum base gate (Figure 2-5).
3. Trap the feeder in-between the vacuum base side guides by sliding each in toward the side plates of the feeder until they gently touch. Tighten side guide knobs to secure in position.

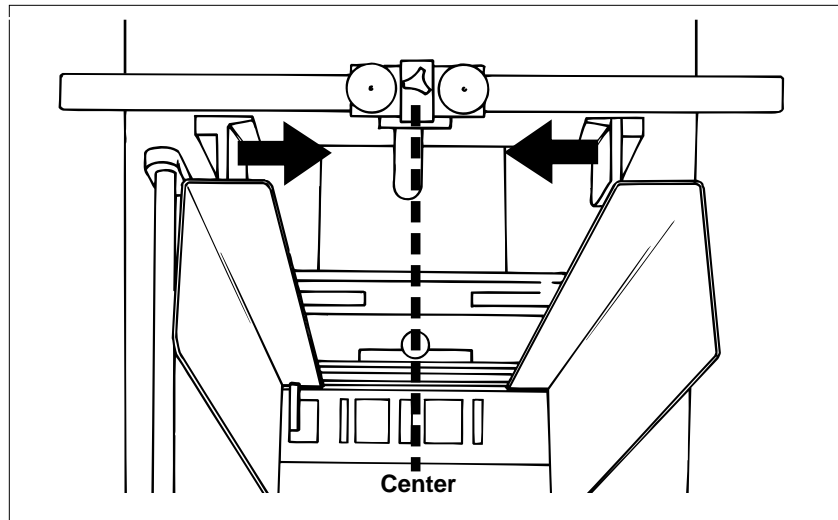
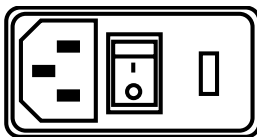

Figure 2-5. Positioning the Feeder on the Vacuum Base

STEP 6: Providing AC Power to Feeder



IMPORTANT

Please verify that the voltage shown at the power inlet module matches the incoming voltage from the power source. If not, please consult with a qualified technician for the procedure on changing the voltage at the machine.

1. Connect IEC320 end of power cord to the feeder (at the power inlet module).
2. Connect three-prong end to nearest AC voltage power source.

STEP 7: Connecting External Run Input

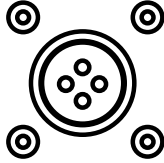

IMPORTANT

This procedure should be performed only by a qualified technician.

Using the two-wire interface cable supplied for vacuum base applications:

1. At the feeder, connect external run input cable to feeder using the two-pin threaded connector on the control panel.
2. At the vacuum base, open access door at end of the lower enclosure to locate start/stop control circuit (Figure 2-6).
3. Route internal run input cable from the feeder to this area.
4. Determine the exact run input voltage required by checking the label on the run input cable.
5. Interface the two bare wire leads at the opposite end of the interface cable to the vacuum base start/stop circuit. This involves splicing the black (GND) wire and red (AC, DC or dry contact) wire to the start/stop circuit.

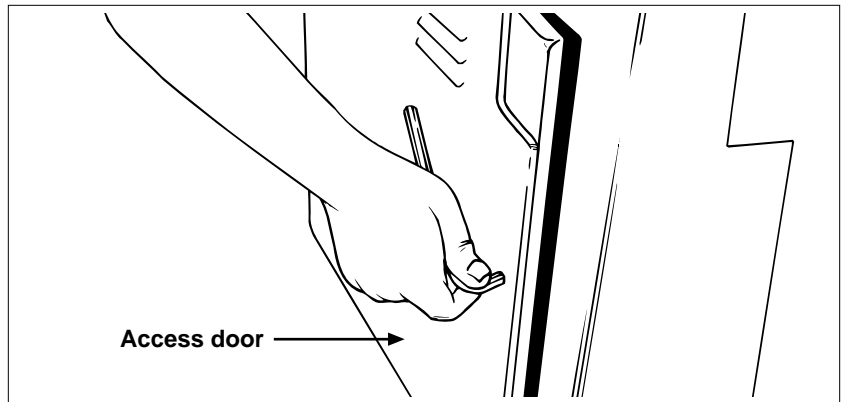

Figure 2-6. Gaining Access to Vacuum Base Start/Stop Circuit

STEP 8: Checking Material Discharge from Feeder

IMPORTANT

Make sure rollers on vacuum base are raised in the highest vertical position so that it does not interfere with the material.

As material leaves the feeder gate cylinder, the trailing edge must be under the hold-down block as the leading edge is entering the vacuum base transfer section. *In other words, there must be a good transfer of material from the feeder hold-down block to the vacuum base transfer section.*

To verify:

1. Slide feeder back far enough to clear the vacuum base side guides. *If necessary, loosen the knobs on both side guides and pull to the outside slightly to allow movement of the feeder.*
2. Insert a piece of material under the hold-down block/ball bearings in such a way that approximately 2/3 of the leading edge is extending out beyond the feeder (Figure 2-7).
3. Slide feeder back into position, making sure it is again centered between the side guides. As you do so, also make sure that the leading edge of the material moves into the transfer section of the vacuum base unobstructed.

STEP 8: Checking Material Discharge from Feeder (continued)

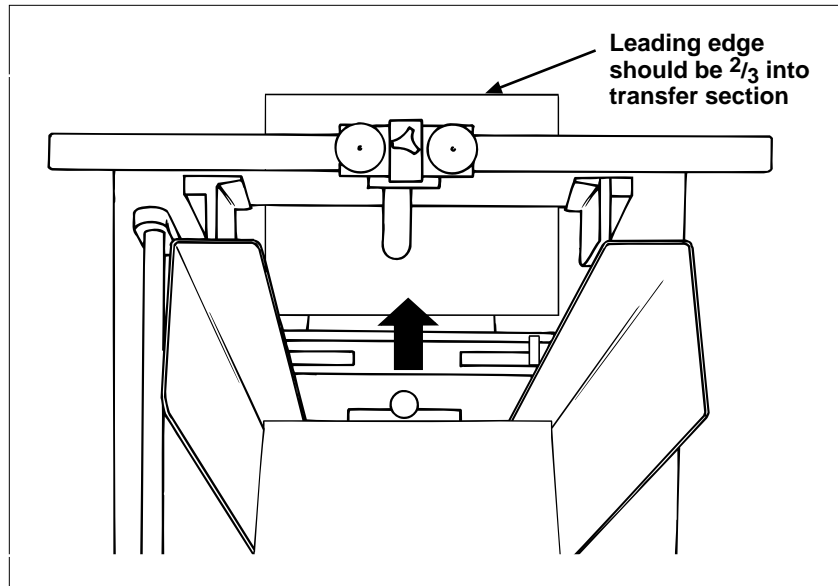

Figure 2-7. Checking for Proper Material Discharge from Feeder to Vacuum Base

4. Check to make sure the material is still under the hold-down block/ball bearings and also resting on the vacuum base transfer section.
5. Trap the feeder in-between the side guides until they gently touch. Tighten side guide knobs.

STEP 9: Miscellaneous Feeder Adjustments

1. Make sure the feeder mode switch is set to “continuous” (Figure 2-8A). This will disable the photo sensor on dual-mode models. Set to "external" run on continuous-mode models.
2. Set the variable speed control (Figure 2-8B) to the lowest speed (counterclockwise). Gradually increase the speed to match the speed of the vacuum base, thus bringing the gap of the material closer together.

IMPORTANT

If you change modes while feeder power is On, the current mode selection will not be applied until you turn power Off and then On again.

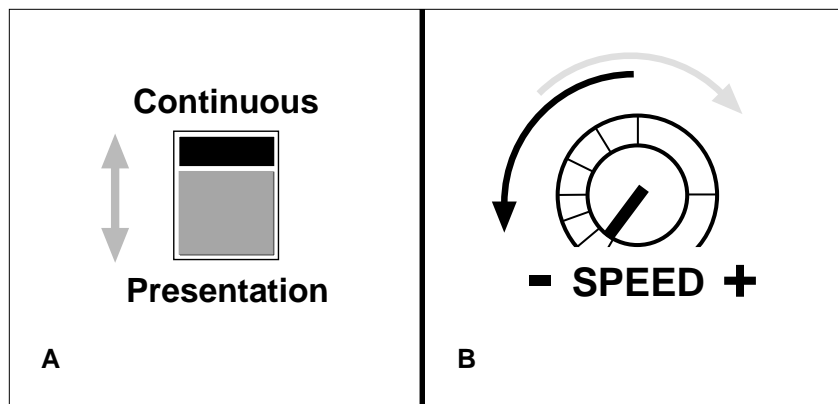

Figure 2-8. Location of Mode Switch and Variable Speed Control

2B: Inserter Installation

Installation of the Reliant 2600/2700 Universal Friction Feeder onto the back deck plate of an inserter is a relatively simple procedure. Several minor modifications to the selected insert station are required prior to mounting, wiring, and aligning the feeder.

To install the feeder, perform the following steps:

- 1: Removing rear guide assembly
- 2: Removing T-plate
- 3: Repositioning separator foot
- 4: Removing suction cup and closing off vacuum hose
- 5: Repositioning insert guide tabs
 - A: Optional step – Installing insert plate guide
- 6: Installing feeder hold-down spring assemblies
- 7: Aligning feeder with insert station
- 8: Securing feeder to inserter
- 9: Installing support pedestal
- 10: Providing AC power to feeder
- 11: Initial feeder photo sensor positioning

STEP 1: Removing Rear Guide Assembly

At the selected insert station, remove the fasteners that hold the inserter rear guide assembly to the inserter back deck plate. Lift rear guide assembly off of back deck plate (Figure 2-9).

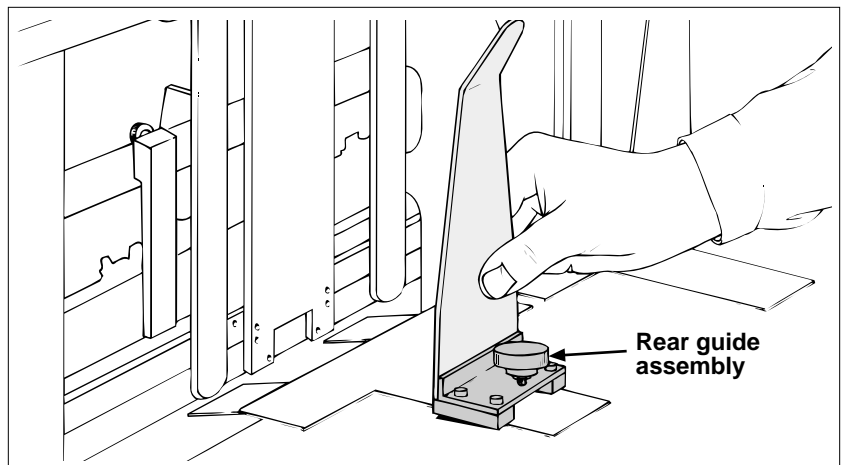

Figure 2-9. Removing Guide Assembly Rear from Inserter

STEP 2: Removing T-Plate

With the rear guide assembly removed, you can now access the inserter T-plate. Simply lift off of back deck plate (Figure 2-10).

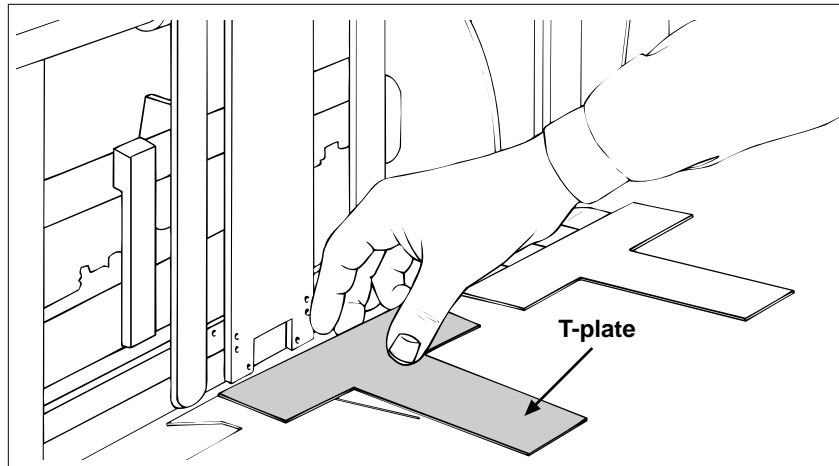

Figure 2-10. Removing T-Plate from Inserter

STEP 3: Repositioning Separator Foot

1. Locate the separator foot at the front side of the inserter station.
2. With a screwdriver, loosen the inserter separator foot and tilt away slightly from insert station assembly (opposite feeder) so that foot does not interfere with material being fed (Figure 2-11).
3. Retighten to secure.

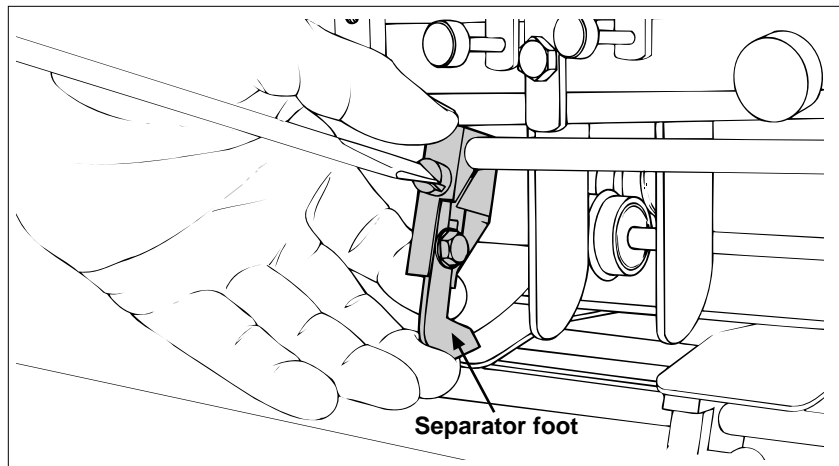

Figure 2-11. Repositioning Separator Foot at Front of Inserter

STEP 4: Removing Suction Cup and Closing Off Vacuum Hose

1. Locate the suction cup and hose from front side of insert station.
2. Remove suction cup from vacuum assembly (Figure 2-12).
3. Lower and tilt the adjustable vacuum assembly forward (by turning the built-in thumbscrew). The vacuum assembly may be moved down and to one side if it interferes with the material being fed.
4. Close off the vacuum hose opening; any convenient plugging method will do.

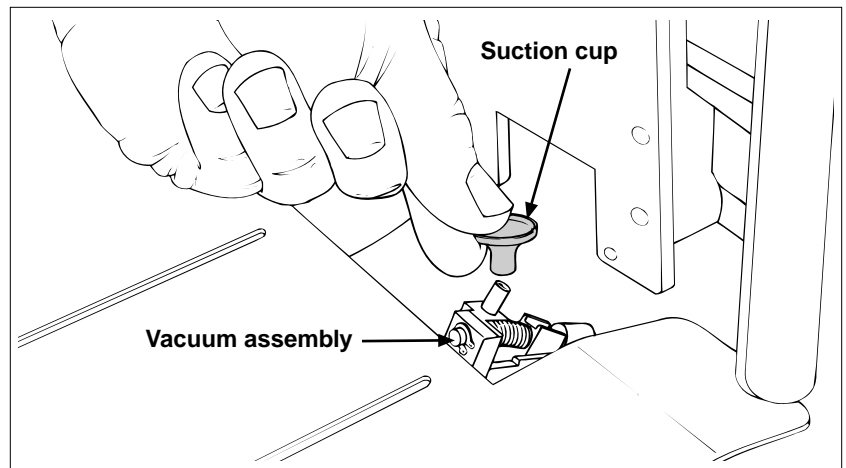

Figure 2-12. Removing Suction Cup from Vacuum Assembly

STEP 5: Repositioning Insert Guide Tabs

1. Cycle the inserter until the gripper arm jaw is approximately .5 in. (12.7 mm) from the hopper plate (leading edge of material exiting feeder stops here).
2. Locate the two insert guide tabs that protrude from under the back deck plate. Bend these tabs as required (either up or down) until their top surface is slightly above the bottom of the gripper arm jaw (Figure 2-13A). The material to be run will rest on these tabs. The bottom of the gripper arm jaw must pass under the material without making contact with it.
3. As it is important that there be adequate clearance between the guide tabs surface and the gripper jaw, use a flat, thin rule (or gauge) to test for clearance (Figure 2-13B). Ideally, the gripper jaw should be fully open when testing.
4. Center the gauge on the guide tabs and slide the gauge back and forth on the tabs, making sure the gripper jaw does not touch the bottom of the gauge (Figure 2-13B).

NOTE

*Mailcrafters' inserters only:
Remove the two insert guide tabs that protrude from the back deck plate. Make a bend in each tab approximately 1.375 in. (34.9 mm) from the tip by placing the tab approximately 1.375 in. (34.9 mm) into the rear guide assembly. Bend the tab slightly and repeat same for second tab. Reinstall insert guide tabs to back deck plate.*

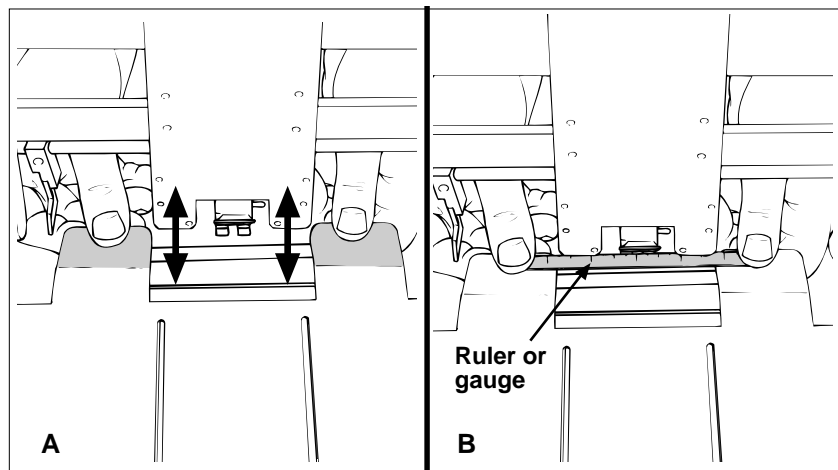

Figure 2-13. Repositioning Guide Tabs and Testing for Clearance

5A: Optional Step — Installing Insert Plate Guide

When feeding materials less than 5 in. (12.7 cm) wide, you must install the provided insert plate guide with your machine. Install it from the underside of the back deck plate using the two provided hex-head screws; reuse the two slots previously used for mounting the rear guide assembly.

To install:

1. Start the screws from the top side of the back deck plate, leaving them loose so you can move the insert plate guide during placement (Figure 2-14A).
2. Position the insert plate guide so that the top surface is slightly above the bottom of the gripper arm jaw.
3. Tighten to secure.
4. As it is important that there be adequate clearance between the guide tabs surface and the gripper jaw, use a flat, thin rule (or gauge) to test for clearance (Figure 2-14B). Ideally, the gripper jaw should be fully open when testing.
5. Center the gauge on the guide tabs and slide the gauge back and forth on the tabs, making sure the gripper jaw does not touch the bottom of the gauge (Figure 2-14B).

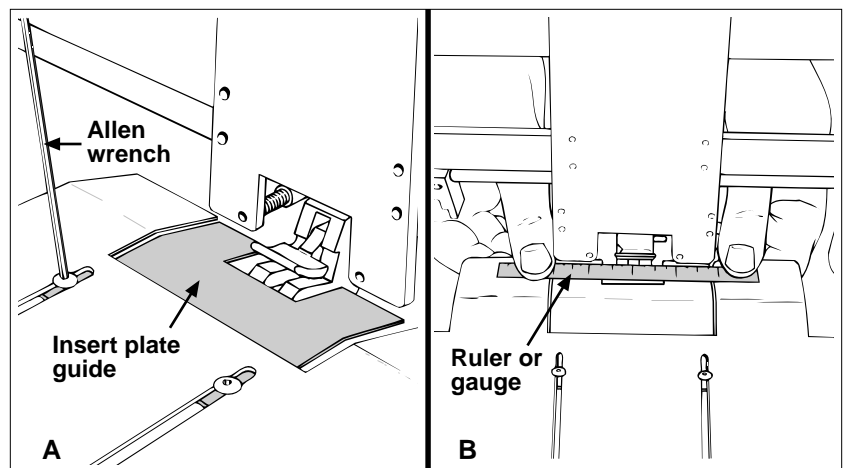
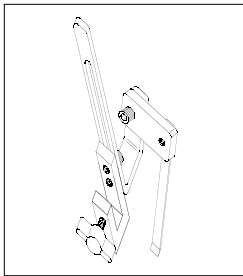

Figure 2-14. Installing Optional Insert Plate Guide and Checking for Clearance

STEP 6: Installing Feeder Hold-Down Spring Assemblies

NOTE

Certain inserter models require hold-down spring assemblies to mount from the bottom side of the crossbar (see figure below). To invert, simply remove screw and invert L-bracket and spring.



1. Using the two provided hold-down spring assemblies (with support bars), place each on the insert station rail (feeder side of inserter).
2. Position each spring support bar so they are equally spaced from each edge of the material to be run (Figure 2-15A).
3. Tighten the built-in wing nut on each to secure.
4. Check for placement and pressure of the hold-down spring assemblies by sliding a piece of material to be run under the springs (Figure 2-15B). There should be a “slight drag” when moving the material back and forth.
5. Make adjustments as required and recheck.

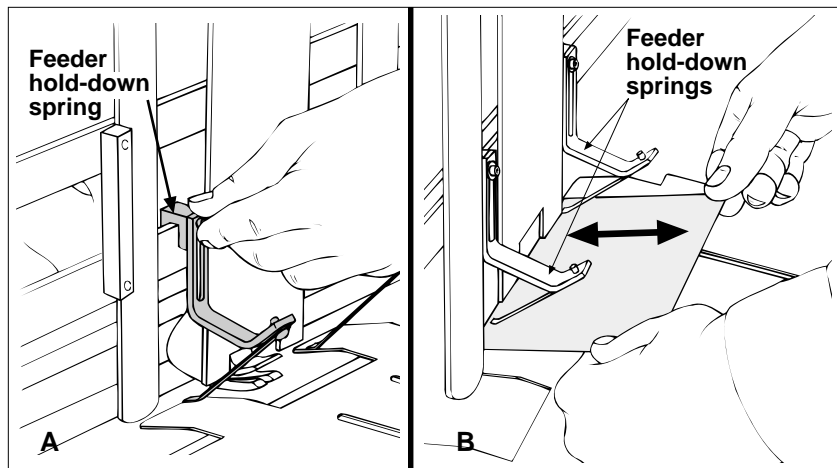

Figure 2-15. Installing Hold-Down Spring Assemblies and Testing for Drag

TIP

Knowing how far from each edge of the material to place the hold-down spring assemblies is a combination of intuition and testing.

TIP

With material inserted between the springs and the insert guide tabs, test the spring tension by sliding the material back and forth. Tension should not be so great that it distorts the material as it moves.

If adjustment is required, loosen the hex-head screw for each spring and move up or down on support bar. Retighten when optimum tension is achieved.

STEP 7: Aligning Feeder with Insert Station

NOTE

If there are brackets or hangers in the way, you may have to adjust the feeder side-to-side by selecting any of the three hole positions in the bottom mounting plate. See figure below.

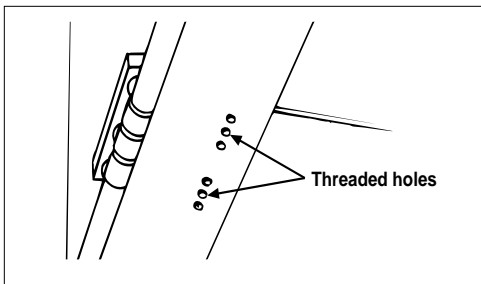

1. Position the feeder on the rear deck plate so the two slots on the back deck plate line up with two threaded holes in the bottom of the feeder (Figure 2-16A).
2. Using the two provided T-handle screws, start these part way into the bottom threaded holes of the feeder base plate from the underside of the back deck plate (but not tight).
3. Make sure a piece of material to be run is placed under the hold-down springs (and centered), with the front edge of the material in-line with the front hopper plate.
4. Carefully slide the feeder toward the gripper arm (Figure 2-16B) until the trailing edge of material fits between the feeder exit rollers (.25-.5 in. or 6.4-12.7 mm of material).

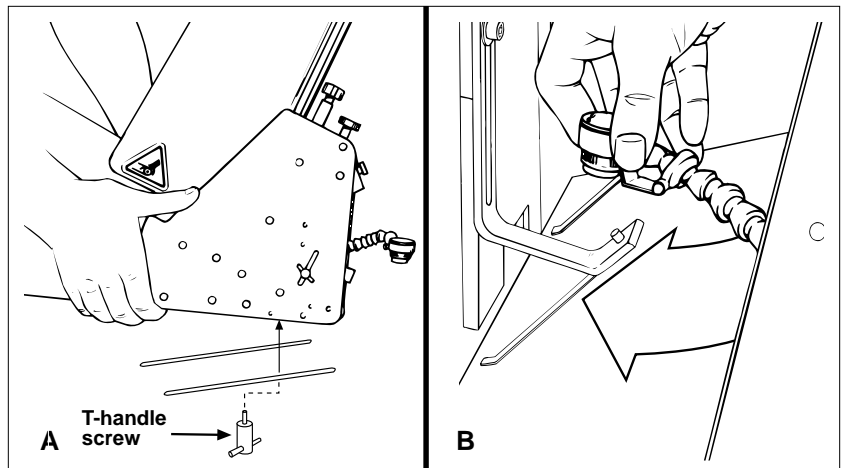
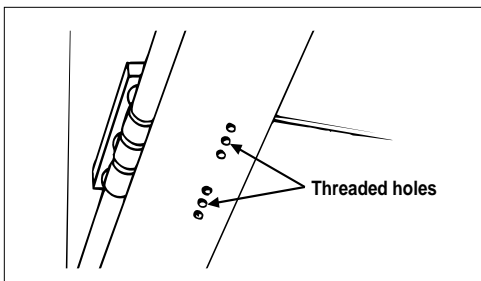

Figure 2-16. Aligning Feeder with Insert Station

STEP 8: Securing Feeder to Inserter

TIP

If you need to move the feeder side-to-side to fine-tune the alignment with the insert station, use any of the three hole positions in the bottom mounting plate. See figure below.



When you are satisfied with the alignment, secure the feeder by tightening the two T-handle screws from underside of inserter rear deck plate (Figure 2-17).

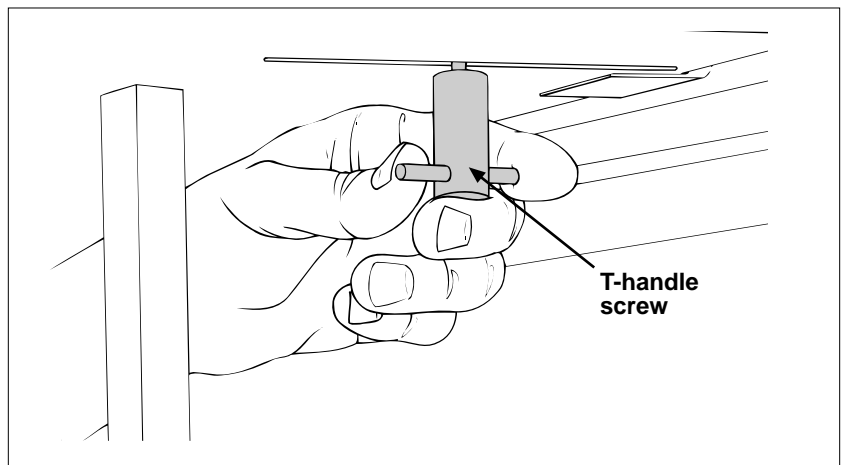

Figure 2-17. Securing Feeder to Back Deck Plate

STEP 9: Installing Support Pedestal

The length and weight of the feeder may cause the rear deck plate of the inserter to flex. A variety of alignment and feeding problems can result from such flexing. *Always use a support stand on all inserter applications.*

To install:

1. Position the pedestal under the rear of the feeder (where support is needed).
2. Loosen both height adjustment knobs on the telescoping support beam (Figure 2-18).
3. Raise the support beam until the L-bracket rests against the bottom of the feeder. Make sure the support pedestal is perpendicular to the feeder before tightening the two adjustment knobs.

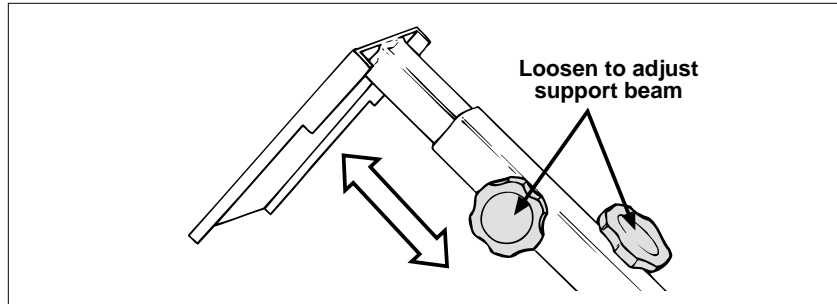
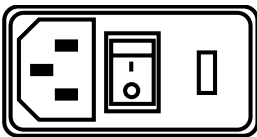

Figure 2-18. Pedestal Installation

STEP 10: Providing AC Power to Feeder



IMPORTANT

Please verify that the voltage shown at the power inlet module matches the incoming voltage from the power source. If not, please consult with a qualified technician for the procedure on changing the voltage at the machine.

1. Connect IEC320 end of power cord to the feeder (at the power inlet module).
2. Connect three-prong end to nearest AC voltage power source.

STEP 11: Initial Feeder Photo Sensor Positioning

NOTE

The final photo sensor adjustment will align slightly to the rear of the leading edge. This is because when the photo sensor signals the feeder to stop, the motor will over-travel slightly.

IMPORTANT

A perpendicular alignment to the material is preferred. However, in many instances you may be limited to an angular alignment due to the constraints of the flexible extension arm.

1. With the machine turned Off, position the photo sensor so it is somewhat centered between the outside edges of the material.
2. Next, adjust the sensor so it points exactly at the leading edge of material being held by the hold-down springs (Figure 2-19). *Use the flexible extension arm to maneuver the photo sensor into position for desired height and angle.*
3. During the final adjustment of the photo sensor, you need to actually load material into hopper, turn the feeder Off, and cycle the inserter. See Section 3, Preparing for Operation, for more information.

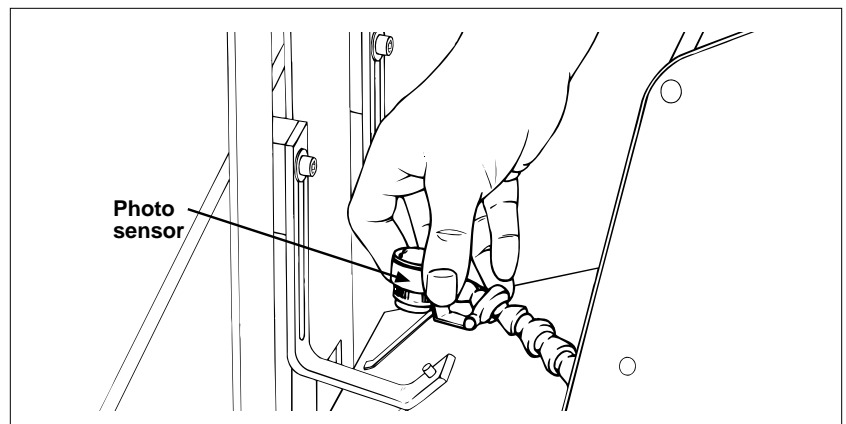

Figure 2-19. Initial Photo Sensor Adjustment

2C: Bryce 16K Ink Jet Printer Base Installation

Interfacing the Reliant 2600/2700 Universal Friction Feeder to the Bryce 16K ink jet printer base is a relatively simple procedure. No modifications to the Bryce 16K base are required prior to mounting, wiring, and aligning the feeder.

To install the feeder, perform the following steps:

- 1: Position the feeder and the Bryce 16K base
- 2: Wire the feeder to the Bryce 16K base
- 3: Provide AC Power to Feeder

STEP 1: Positioning the Feeder and the Bryce 16K Base

Using the optional roll-up stand provided for Bryce 16K base applications:

1. Position the feeder (and stand) at the “upstream” end of the conveyor.
2. Adjust the feeder stand so that outermost discharge roller of feeder is at the same height as the top of the Bryce 16K base conveyor belt.
3. Allow for a horizontal distance from .25 in. (6.35 mm) to .50 in. (12.7 mm) between the feeder discharge roller and the Bryce 16K base conveyor belt.

STEP 2: Wiring the Feeder to the Bryce 16K Base

External Run Input

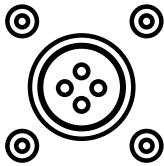

Using the two-wire interface cable supplied for Bryce 16K base applications:

1. At the feeder, connect external run input cable to feeder using the two-pin threaded connector located on the control panel.
2. At the Bryce 16K base, remove panel to access the main control circuit board.
3. Splice the black (GND) wire and red (+24 V) wire on the opposite end of the interface cable into the GND and +24 V wires connecting the Bryce 16K base main circuit board and the shingling conveyor motor.

IMPORTANT

This procedure should be performed only by a qualified technician.

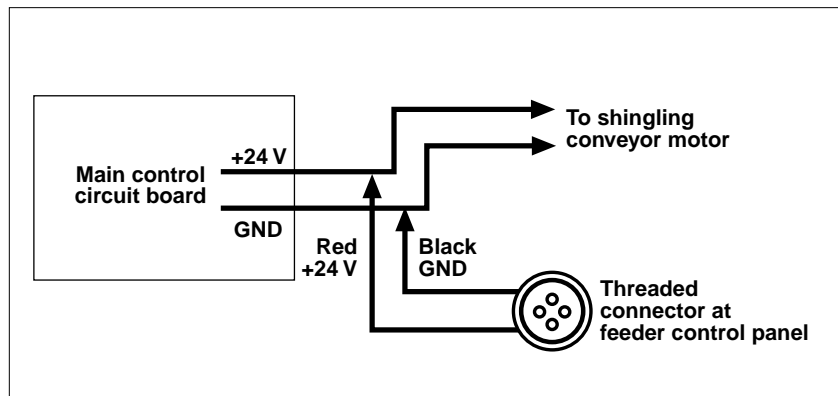
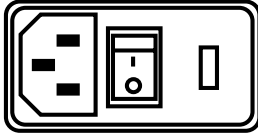

Figure 2-20. Wiring the Feeder into the Bryce 16K Base

STEP 3: Providing AC Power to Feeder

1. Connect IEC320 end of power cord to the feeder (at the power inlet module).
2. Connect three-prong end to nearest AC voltage power source.



IMPORTANT

Please verify that the voltage shown at the power inlet module matches the incoming voltage from the power source. If not, please consult with a qualified technician for the procedure on changing the voltage at the machine.

3 Preparing for Operation



When performing initial feeder adjustments prior to operation, always make sure you turn Off the main power switch and disconnect all equipment from the electrical power source. Failure to do so can expose you to a potential startup and moving parts which can cause serious injury.

Do not attempt to make any adjustments while the feeder and machine of application are running. Failure to do so can expose you to moving parts which can cause serious injury. Do not wear loose clothing when operating the feeder.

Avoid making adjustments with loose or unsecured parts. This can potentially damage parts.

Once the Streamfeeder Reliant 2600/2700 Universal Friction Feeder is installed on your host system, you are then ready to prepare the machine for operation. To do so, you must perform several adjustments with the material you are going to be feeding. And, you must do a test run with this material to verify that it is set correctly before you begin cycling the feeder with your particular application. *You will have to perform this procedure for material that you plan to feed.*

The adjustments you must make (in order) are as follows:

- 1: Gate assembly adjustment
- 2: Side guides setting
- 3: Back wedge adjustment
- 4: Top roller hold-down assembly setting
- 4A: Optional step – Final photo sensor adjustment for inserter applications only
- 5: Verifying proper installation

STEP 1: Gate Assembly Adjustment



Excessive lowering of the gate assembly can damage product or lead to premature wear of the O-rings or feed belts.



If material does not move freely, then the gate assembly is too tight. This can lead to premature wear of the O-rings or feed belts.

TIP

A wider gap between product and belt provides the highest tolerance for curled and bent edges.

NOTE

Feeding problems will occur with either too much material in the hopper, or too large a gap between the gate assembly and the material.

Procedure

To adjust the gate assembly for proper gap:

1. Slide a single sheet of test product under the gate assembly. It may be necessary to pull up on the adjustment knob to allow the piece to be inserted.
2. Test the piece for clearance. Grasp the product with two hands and slide it front-to-back under the gate assembly. A proper adjustment allows a slight amount of drag on the top of the piece.
3. Adjust the knob on the gate assembly until the piece has the desired drag. Turn the knob clockwise to increase clearance or counterclockwise to decrease clearance.
4. Repeat the drag tests and adjust as needed to achieve acceptable clearance.

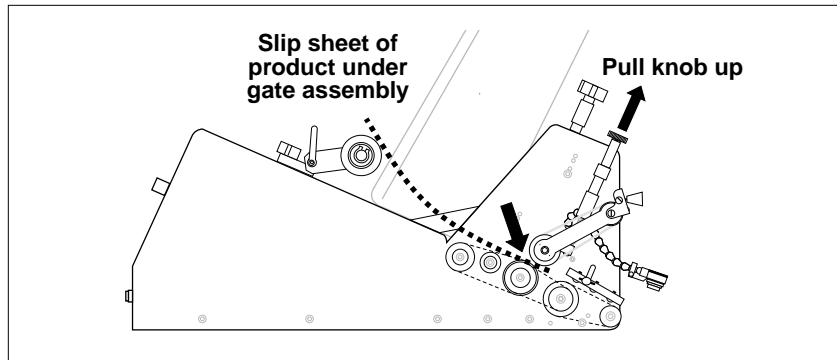

Figure 3-1. Lifting Gate Assembly Upward to Insert Material

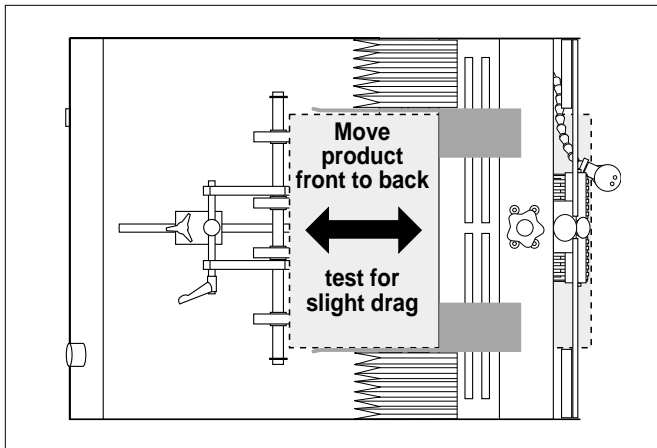

Figure 3-2. Using One Piece of Material to Set Gap

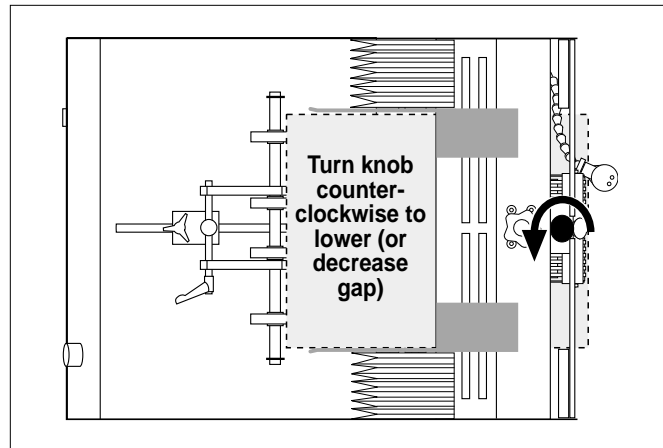

Figure 3-3. Adjusting Gate Assembly for Correct Gap

STEP 1: Gate Assembly Adjustment (continued)

NOTE

When feeding product with varying thickness throughout, it may be necessary to turn both adjustment rollers 1-2 **full turns** counterclockwise to compensate for the differential thickness. This procedure allows the gate horizon to “float.”

IMPORTANT

The adjustment knob set screws are pre-set at the factory to lock the knob to the threaded rod. **DO NOT OVER-TIGHTEN!** Over-tightening the set screws may damage the components.

To adjust the gate for effective material skew control, follow these steps:

1. Repeat drag test.
2. Test the piece for uneven side-to-side drag. Grasp with two hands and slide it front-to-back under the gate assembly. A proper adjustment allows for equal drag on the left and right sides of the piece of material.
3. To compensate for greater drag on one side of the material, turn the *opposite* adjustment roller *counterclockwise* 1/8 turn. Next, turn the other adjustment roller *clockwise* 1/8 turn.
4. Repeat drag tests and adjust as needed until equal drag is achieved. You may need to repeat this procedure after observing the feeder cycling (refer to Section 4, How to Operate).

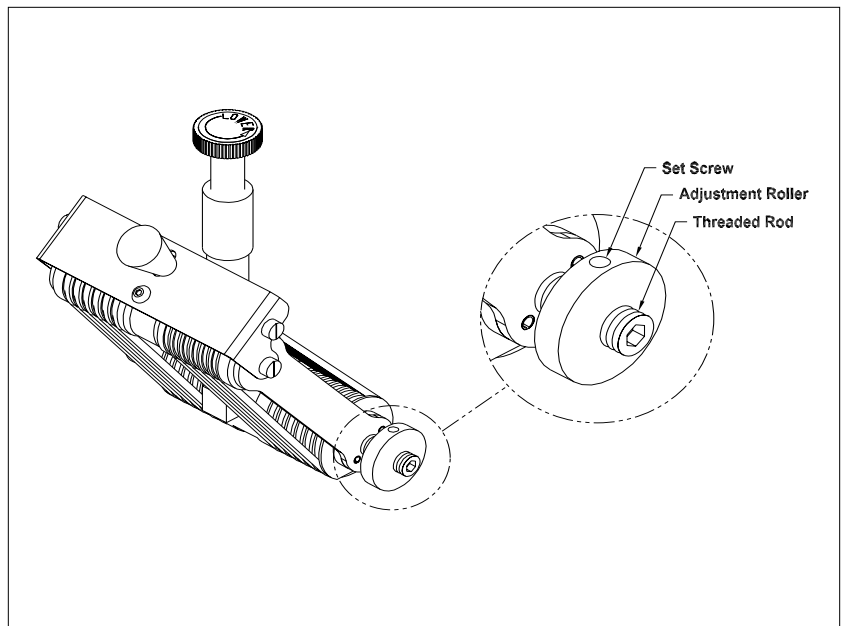

Figure 3-4. Horizon Adjustment (shown on Advancing O-Ring Gate)

Changing From Factory Set High-Tension to Low-Tension



Excessive lowering of the gate assembly can damage material and/or lead to premature wear of the O-rings or feed belts.

IMPORTANT

When changing from a low-tension to high-tension setting, you may have to adjust the stack height downward to prevent feeding problems.

NOTE

Certain types of single-sheet material may require even more tension than the high-tension setting can provide. To increase tension even further, place a washer between the cylinder and spring.

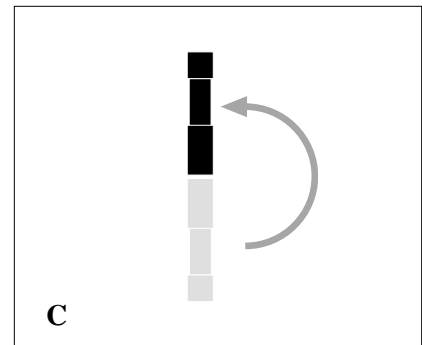
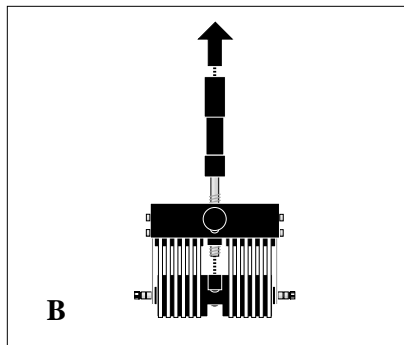
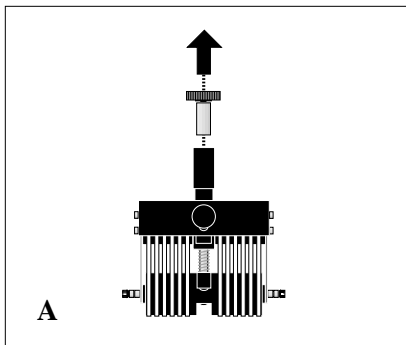
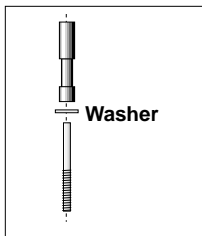

Figure 3-5. Adjusting Gate Assembly for Low-Tension

Procedure

Certain types of material may demand that you change the gate assembly from a *high-tension* setting to a *low-tension* setting (for example, irregular shaped material).

To change the spring from a *high* to a *low* tension, follow these steps:

1. Remove the gate assembly from gate bracket assembly. To do so, pull cylinder down with one hand, lift up on knob with other, and tip at slight angle to remove.
2. Remove the adjustment knob by turning counterclockwise. Then lift the cylinder off of top of spring.
3. Turn the cylinder around so that the cylinder collar faces up. Then place the cylinder on top of the spring.
4. Replace the adjustment knob (make about 8 revolutions of the knob before reinstalling gate assembly on gate plate).

STEP 2: Side Guides Setting

TIP

A good “rule-of-thumb” measurement to use is about .0625 in. (1.6 mm) between material edge and side guide (.125 in. or 3.1 mm overall).

NOTE

There are two types of side guide adjustments available:

- 1) *Single-Knob:* Both side guides controlled simultaneously by a single knob (as shown in Figures 3-6 and 3-7).
- 2) *Dual-Knob:* Each side guide controlled by a separate knob.

The side guides hold the stack of material being fed, and they guide the material through the feeder in a straight line of movement.

Adjust the side guides so the material stack maintains uniformity from top to bottom, with no drifting or binding. Adjustments are made *horizontally*.

Make sure the space between the side guides can accommodate the size of the material being fed. Consider the following as you adjust the guides:

- An initial starting point should always be that each guide is of equal distance from the center point of the machine.
- Each edge of the material should rest equally on the belts, on both sides of the gate assembly (or equidistant spacing). *However, there can be certain instances where guides do not need to be centered due to material characteristics. This is called offset spacing.*
- Adjust both side guides to be as close as possible to either sides of the material, without causing binding, curling of edges, or resistance to movement.

Procedure

Single-Knob Side Guides. To adjust each side guide for proper *equidistant* horizontal spacing using the single-knob adjustment, follow these steps (Figure 3-6):

1. Place a small stack of material in the hopper.
2. Using the side guides adjustment knob (centrally located between the two guides), turn in either direction until guides are located at the recommended distance from the material: .0625 in. (1.6 mm) from each edge, .125 in. (3.1 mm) overall.
3. Visually check both guides for proper spacing from material.

Dual-Knob Side Guides. To adjust each side guide for proper *equidistant* horizontal spacing using the dual-knob adjustment, follow these steps:

1. Place a small stack of material in the hopper.
2. Start by loosening each side guide wing adjuster (counterclockwise). This will allow you to move each side guide as needed.
3. Grasp the lower part of each guide and slide to the recommended distance from the material: .0625 in. (1.6 mm) from each edge, .125 in. (3.1 mm) overall. Tighten each wing adjuster after you establish proper position for each guide.
4. Visually check both guides for proper spacing from material.

STEP 2: Side Guides Setting (continued)

Single-Knob Side Guides. To adjust each side guide for proper *offset* horizontal spacing using the single-knob adjustment, follow these steps (Figure 3-7):

1. Push down on the side guides spring-loaded adjustment knob to disengage guides from gear mechanism.
2. Grasp whichever side you wish to offset first and move into position.
3. Place a small stack of material in the hopper, with edge of paper against offset guide.
4. Move the second side guide so that it is located at the recommended distance from the material: .0625 in. (1.6 mm) from each edge, .125 in. (3.1 mm) overall.
5. Lift up on the spring-loaded adjustment knob so that the guides lock into place.
6. Visually check both guides for proper spacing from material.

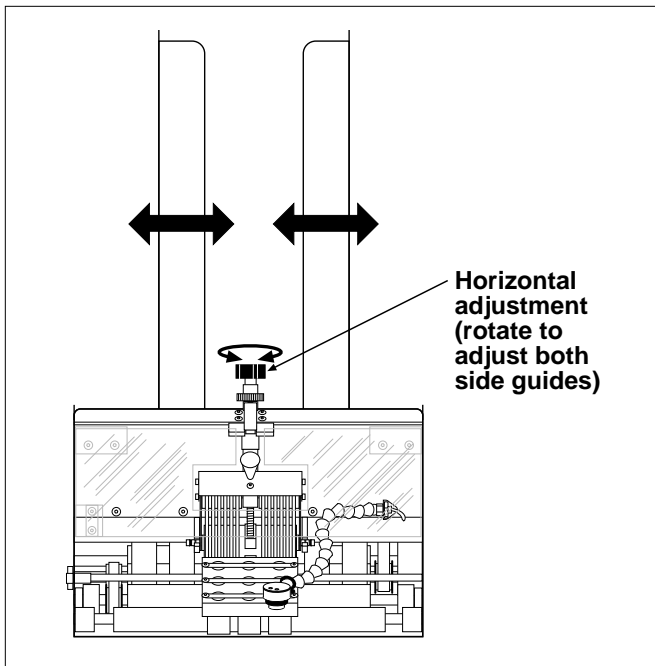

Figure 3-6. Horizontal Adjustment of Side Guides

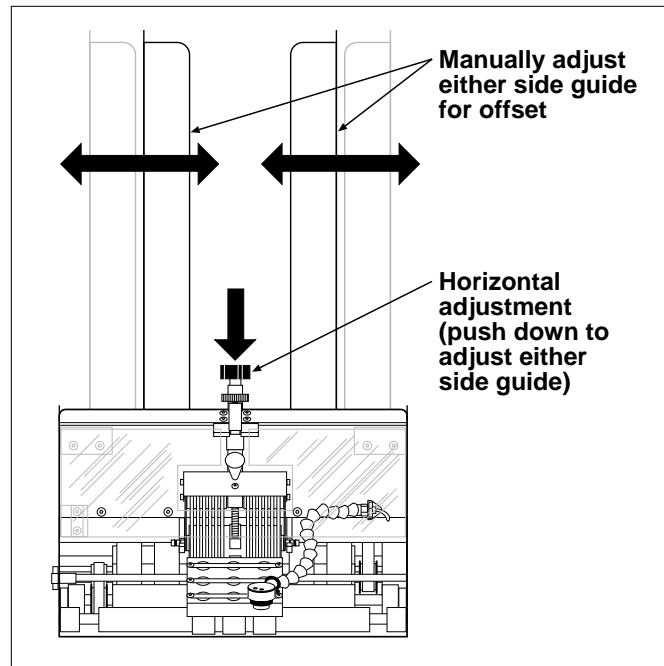

Figure 3-7. Individual Side Guide Offset

Dual-Knob Side Guides. To adjust each side guide for proper *offset* horizontal spacing using the dual-knob adjustment, follow these steps:

1. Start by loosening each side guide wing adjuster (counterclockwise). This will allow you to move each side guide as needed.
2. Repeat steps 2-5 above.
3. Tighten each wing adjuster after you establish proper position for each guide.
4. Visually check both guides for proper spacing from material.

STEP 3: Back Wedge Adjustment

NOTE

Keep in mind that the back wedge works with the gate assembly to provide the proper lift, curvature of the material, and proper belt/material contact to separate and feed one sheet at a time.

TIP

There are a number of feeding problems which can be solved by simply adjusting the back wedge to different positions. Some of these problems include double feeds, skewing, twisting, poor singulation, ink or varnish buildup on the belts, and jamming at the gate assembly area.

NOTE

For more information about optional wedges and their use with various materials, see Section 7, *Additional Wedges*.

NOTE

Moving the back wedge too far forward to the gate assembly can create a pinch point between the wedge and the material. If moving the back wedge in is not effective, then an optional wedge may be required. See Section 7, *Additional Wedges*, for more information.

Procedure

To adjust the back wedge for initial proper positioning, follow these steps:

1. Grasp a handful of material, approximately 2 to 2.5 in. (5 to 6 cm) thick, and preshingle the edges with your thumb (Figure 3-8).
2. Place the preshingled material in the hopper so the edges rest against the curvature of the gate assembly (Figure 3-9).
3. Turn the back wedge wing-nut adjustment counterclockwise to loosen the wedge (Figure 3-9).

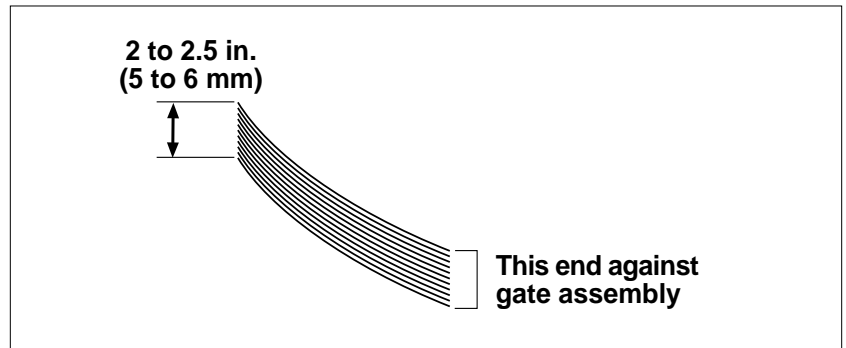

Figure 3-8. Preshingling a Small Stack of Material By Hand

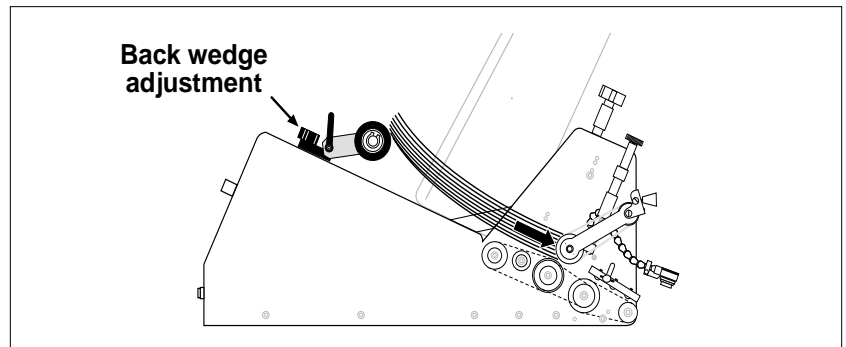

Figure 3-9. Positioning Material Prior to Loosening Back Wedge

4. Move the back wedge forward and backward until the bottom sheet is not touching the table top (Figure 3-8). A good starting point is to measure about .625 in. (16 mm) from the bottom sheet to front edge of table top. Then as you test, you can “fine-tune” from this point. You can also fine-tune back wedge location by loosening the roller swivel wing-nut to pivot the rollers back and forth (Figure 3-9).

STEP 3: Back Wedge Adjustment (continued)

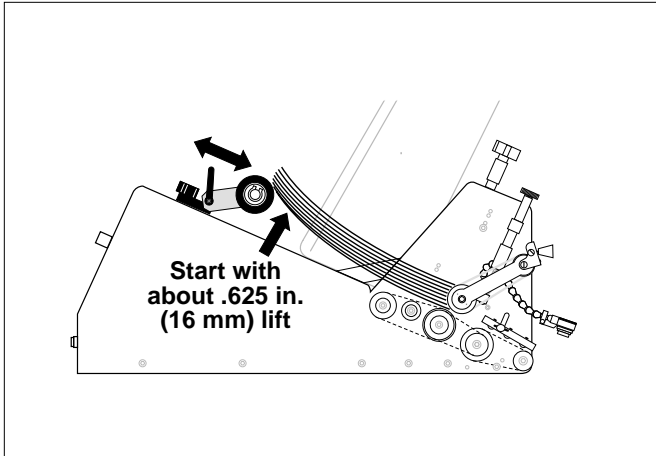

Figure 3-10. Adjusting Back Wedge for Parallel

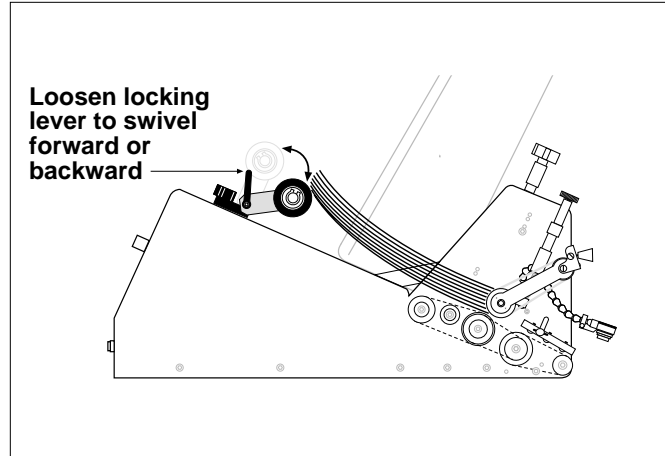

Figure 3-11. Evenly Adjusting Individual Wedges

5. Make sure the edge of the back wedge assembly is parallel with the edge of the material stack (Figure 3-12). Adjust as required and then tighten wing-nut.
6. Check that individual rollers are evenly spaced to provide enough support to lift the material off the table top and feed belts, without any bowing or twisting (Figure 3-13). Refer back to page 28 for guidelines on adjusting individual rollers for thinner material.

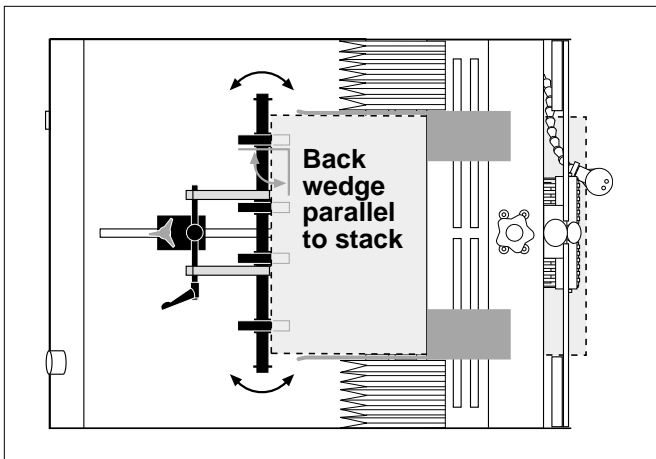

Figure 3-12. Adjusting Back Wedge for Parallel

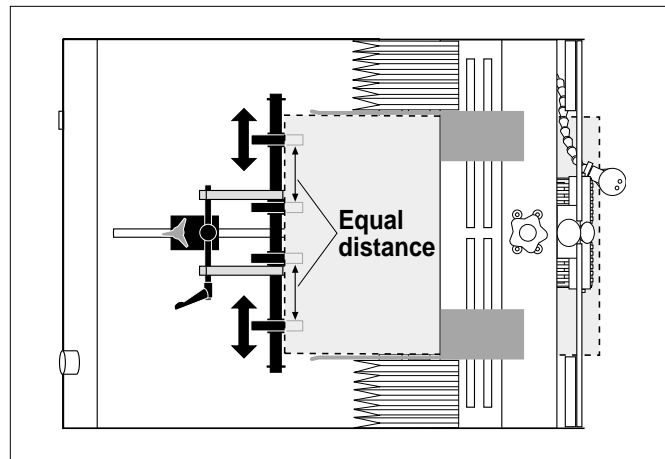

Figure 3-13. Evenly Adjusting Individual Wedges

STEP 4: Top Roller Hold- Down Assembly Setting

The top roller hold-down assembly consists of an array of ball bearings in a block that is mounted on a movable shaft just above the discharge belt. This assembly rests on top of the material as it exits the gate assembly area. Incorrect hold-down pressure can damage material.

Adjust the top roller hold-down assembly for proper amount of pressure so the material exits the discharge area efficiently and squarely.

Procedure

To adjust the top roller hold-down assembly for proper pressure, follow these steps:

1. Loosen the two T-nuts on either side of the shaft (Figure 3-14A).
2. Lift up on the top roller hold-down assembly and insert one piece of material to be fed under the rollers (Figure 3-14B). Then allow the assembly to lightly rest on top of the material.
3. Retighten (or lock) the two T-nuts to secure the top roller hold-down assembly in position. The proper pressure (or gap) should be retained.
4. Verify that assembly is set for proper amount of pressure (or drag) by sliding the material back and forth. There should be a very slight amount of drag.

IMPORTANT

If the roller farthest from the gate assembly is tighter than the roller closest to the gate assembly, jamming may occur.

If either adjustment is too tight, material damage may occur.

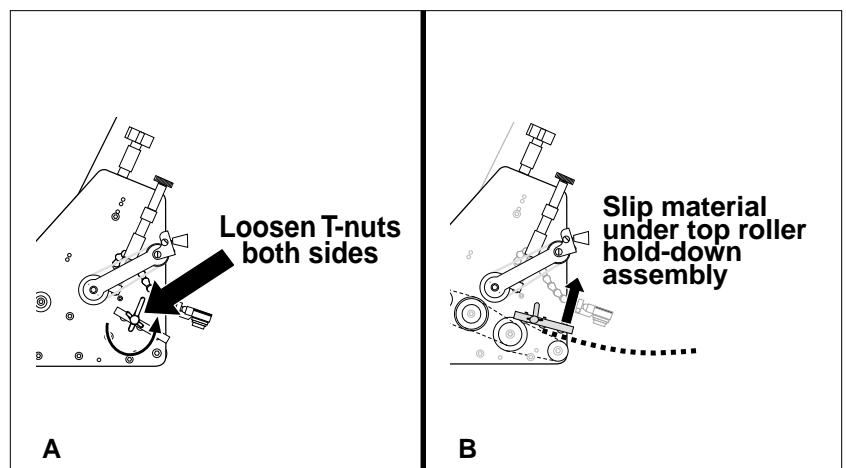

Figure 3-14. Adjusting Top Roller Hold-Down Assembly

4A: Optional Step — Final Photo Sensor Adjustment (Inserter Applications Only)

NOTE

Standard photo sensor shipped from the factory is a diffuse reflective detector. No adjustment for gain is required or necessary.



Only adjust the photo sensor when the feeder power is Off. Do not attempt to adjust the photo sensor while the feeder power is On or while the feeder is running. Doing so will expose you to pinch points which can cause injury to hands or fingers.



Potential damage to feeder parts is avoided if adjustments are made when the feeder power is Off.

IMPORTANT

Observe the overlap between the trailing edge of the bottom sheet and leading edge of the next sheet. It should be approximately .25 in. (6.4 mm) to .5 in. (12.7 mm). If not, refer back to Section 2, 2B: Inserter Installation, Step 7, Aligning Feeder with Inserter Station, for more information.

The photo sensor is mounted on the flexible extension arm to detect the leading edge of a piece of material to be staged. When the gripper jaw pulls the material from the feeder, the photo sensor no longer “sees” the material and sends a signal to start the feeder. The feeder then moves another piece of material into place, and then stops.

For the photo sensor to be effective, it must be adjusted so each time the feeder starts, the leading edge of the material being fed stops in-line with the front hopper plate. The feeder should stop so the trailing edge of the material has minimal overlap with the next trailing edge exiting the gate assembly area.

Procedure

To adjust the photo sensor for proper positioning, follow these steps:

1. Prepare your adjustment by loading the hopper with approximately 2 to 2.5 in. (5 to 6 cm) of material. Make sure you preshingle the stack so that material rests against the curvature of the gate assembly.
2. Use your finger or thumb on the drive belt or one of the feed rollers to manually move the bottom sheet of material through the gate assembly area and under hold-down springs. Continue until material leading edge is in-line with front hopper plate, then stop (Figure 3-15).
3. Turn the feeder power On by pushing the horizontal line (—) at the **Power** On/Off rocker switch.

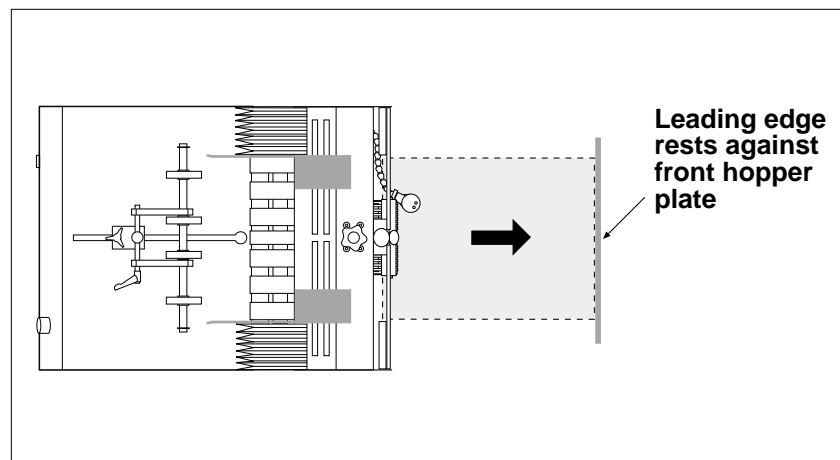

Figure 3-15. Moving the First Sheet Into Position

4A: Optional Step — Final Photo Sensor Adjustment (Inserter Applications Only) (continued)

IMPORTANT

Sensing range from the lens to the paper should not exceed 2 in. (5.08 cm).

NOTE

If the photo sensor is set too far from the surface of the material, the feeder will "stream" out product and feeder will go into "time-out." This indicates the sensor is out of range and therefore will not "see" the target.

IMPORTANT

On the feeder, such objects as shafts, guides, belts, and supports may cause false "reads" if the photo sensor is not adjusted properly for the material (or target). The resulting problem can be intermittent or continuous feeding. See Section 5, Operational Troubleshooting, for a solution.

IMPORTANT

Black opaque objects may require a special photo sensor. If the photo sensor fails to stop the feeder when the material is within the target range, consult with a qualified technician.

4. Simulate gripper jaw action by manually grasping the leading edge of the bottom sheet and pulling completely away from the gate assembly area. Once a piece is removed from the gripper jaw, the sensor sends a signal to the feeder to "stage" the next piece. The leading edge of the "staged" piece should be in-line with the front hopper plate.
5. After running several sheets through, turn the feeder power Off by pushing the circle (O) at the **Power On/Off** rocker switch. Adjust the photo sensor as needed to achieve the correct stopping point. *An optimum setting is to aim the sensor slightly to the rear of the leading edge (Figure 3-16).* This compensates for the slight over-travel of the motor after it turns Off, thus allowing the leading edge to stop in-line with the front hopper plate.
6. Retest the feeder as needed until optimum results are achieved.

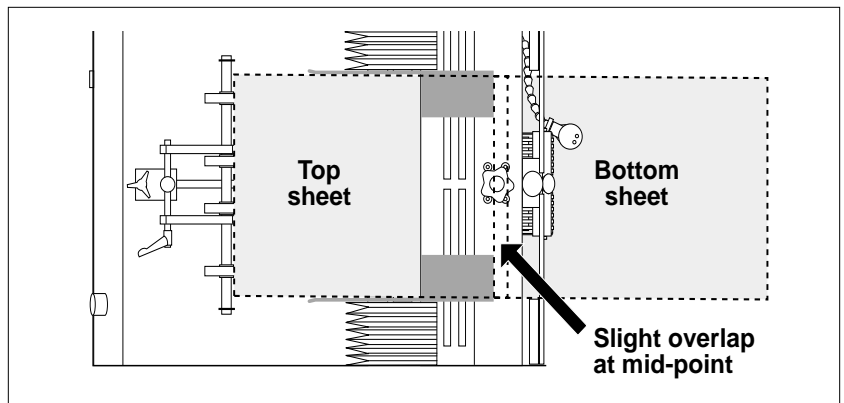

Figure 3-16 . Optimum Alignment of Photo Sensor

STEP 5: Verifying Proper Installation

Before you move on to Section 4, How to Operate, verify that the installation is properly done by reading the following to prevent any operational problems:

- Review of installation
 - Manual test to verify
-

Review of Installation

Please notice the three applications covered in the text to follow: *vacuum base*, *inserter*, and *Bryce 16K base*.

Vacuum Base Applications

For the *vacuum base* installation, it is recommended that you check the following to ensure a proper installation:

1. Review all vacuum base preparations to make sure they have been properly done.
2. Check interface connection.
3. Check electrical connection.
4. Make sure feeder is properly positioned (or centered).

Inserter Applications

For the *inserter* installation, it is recommended that you check the following to ensure a proper installation:

1. Review all inserter preparations to make sure they have been properly done.
2. Check alignment of feeder with station.
3. Check electrical connection.
4. Make sure feeder is properly secured to the deck plate.

Bryce 16K Base Applications

For the *Bryce 16K base* installation, it is recommended that you check the following to ensure a proper installation:

1. Make sure feeder is positioned close enough to the conveyor so as to allow a smooth transition of material from the feeder to the conveyor.
2. Check to make sure feeder is properly aligned horizontally and vertically with conveyor. Re-adjust if necessary.

STEP 5: Verifying Proper Installation (continued)

Now that you have made all the necessary adjustments for operation, it is recommended you verify material singulation and separation at the feeder for your particular application. Before you power-up and run your machine with a full hopper, manually feed several sheets of material through the gate assembly area.

NOTE

If the gate assembly is too tight, the feeder will have difficulty pulling the material through the gate assembly area. This will cause “missed” feeds.

NOTE

Moving the back wedge too far forward to the gate assembly can create a pinch point between the wedge and the material. If moving the back wedge in is not effective, then an optional wedge may be required. See Section 7, Additional Wedges, for more information.

TIP

For certain types of materials, you may have to position the material “off-center” to prevent any skewing effect.

Manual Test to Verify (for All Applications)

Prepare your test by loading the hopper with approximately 2 to 2.5 in. (5 to 6 cm) of material. Make sure you preshingle the stack so that material rests against the curvature of the gate assembly.

1. Manually feed several sheets of material slowly through the gate assembly area. Move the drive belts by pressing your thumb against the discharge belt.
2. Observe how individual material enters and exits the gate assembly area. Remember, a properly set gap will allow each new sheet to enter at about the center line of the cylinder while the bottom sheet is exiting the gate assembly area (Figure 3-17). Ideally, this means a slight overlap of both the first sheet and the second sheet (.125 in., or 3 mm) at the gate assembly area. The overlap occurs as the bottom sheet is exiting, and the next sheet is entering.
3. If feeding doubles, move the wedge in towards the gate assembly. Test again.
4. If sheets are overlapping excessively or, if the machine is feeding doubles, reduce the gap slightly by moving the knob about 1/8 turn counterclockwise. Test again.
5. As material moves through the hold-down area, check for any skewing or jamming. Also check for damage to the material.
6. If this or other feeding problems still persist (slipping, skewing, jamming), review all the adjustment procedures in Section 3, Preparing for Operation.

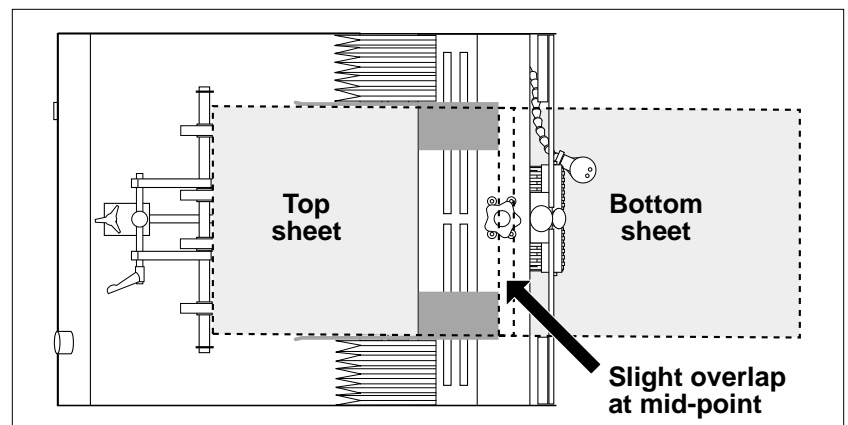

Figure 3-17. Optimum Overlap and Separation of Material

4 How to Operate

This section provides a *sequence of operation* for the Reliant 2600/2700 Universal Friction Feeder. It also provides information for *clearing a jam* and for *shutdown*.

Sequence of Operation

Successful power-up and operation is assured if you apply the following sequence of steps:

- 1: Loading material in the hopper
- 2: Determining stack height
- 3: Powering On feeder
- 4: Setting/adjusting speed (inserter applications only)
- 5: Running test cycles
- 6: Final check

STEP 1: Loading Material in the Hopper

NOTE

Preshingling prevents multiple sheets from jamming under the gate assembly at startup.

NOTE

If you wish, loading of material can be accomplished from the front side of the inserter.

1. Start by preshingling by hand a small stack of material (Figure 4-1) so that it conforms to the curvature of the gate assembly. Push in gently to make sure lead edges touch the gate bracket assembly and front edges of the hopper guides (Figure 4-2).
2. At the back wedge, notice how it helps lift the trailing edges of the material off the table top and feed belts. Also notice how the lifting helps to push the preshingled edges against the curvature of the gate assembly (Figure 4-2).

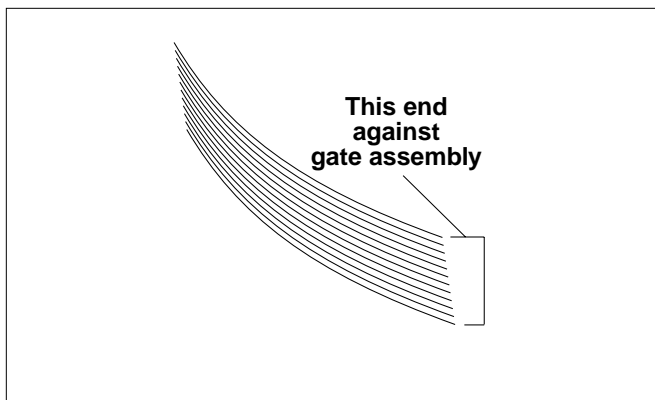

Figure 4-1. Preshingling of First Stack

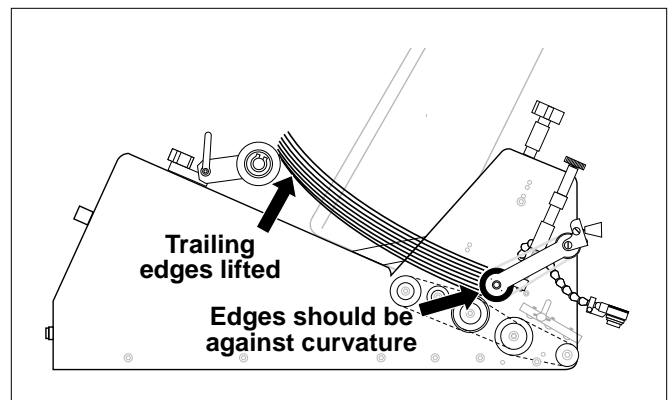

Figure 4-2. Leading Edges Against Gate Bracket Assembly and Side Guides

STEP 2: Determining Stack Height

TIP

Stack height affects the downward pressure on the feed belts. Greater downward pressure can increase the chances for double feeds.

1. Gradually add more material to the hopper after the initial stack is formed around the gate assembly. As stack height will have a preferred minimum and maximum, you will have to experiment to determine effective range of height (Figure 4-3).
2. Make sure the material is loaded in the hopper as straight as possible. Before adding to hopper, “jog” each hand-full of material on a flat surface to make sure lead edges are even. As you add each handful, gently push in each stack so that lead edges rest firmly against front of side guides.

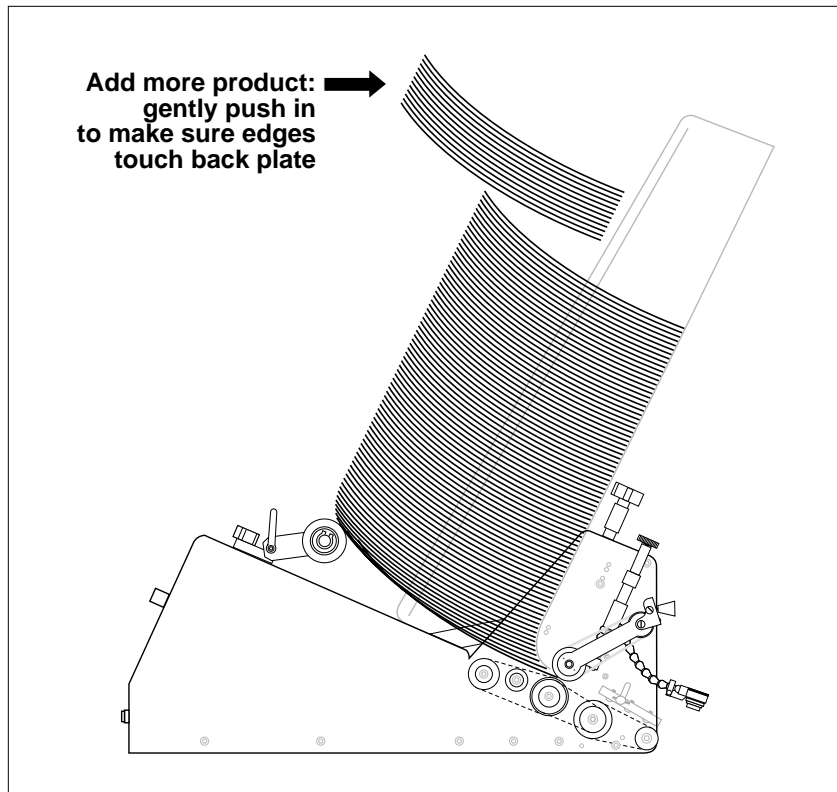
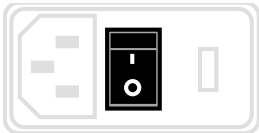

Figure 4-3. Adding More Material to Hopper

STEP 3: Powering On Feeder



Turn the feeder power On by pushing the horizontal line (—) at the **Power On/Off** rocker switch.

- *For vacuum base and Bryce 16K base applications only (continuous mode):* Feeder motor will not run until the entire base power switch is turned On (feeder On/Off is controlled via external run input cable).
- *For inserter applications only (presentation mode):* As the photo sensor “sees” the leading edge, the feeder motor should turn Off. Check the leading edge of bottom sheet. It should be in-line with the front hopper plate and ready for cycling.

STEP 4: Setting/Adjusting Speed

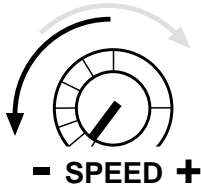

Note: The following applies to all applications, including both “presentation mode” and “continuous mode.”

1. Set the variable speed control to the lowest speed (counterclockwise).
2. Start by slowly turning the control clockwise to gradually increase feeder speed to coincide with the production line speed of your particular application.

STEP 5: Running Test Cycles

For vacuum base applications:

1. With the feeder already fully loaded and powered On, run the vacuum base through several cycles.
2. Notice transition of material from feeder gate assembly area to the transfer area of the vacuum base. Adjust feeder horizontally as needed (refer back to Section 2, Installing the Machine).
3. Adjust feeder speed as needed to coincide with transport belt speed.

TIP

It might be helpful to know that a properly set gap will allow the leading edge of a sheet to enter at about the center line of the cylinder (refer back to Figure 3-17) as the previous or bottom sheet is exiting the gate assembly area.

For inserter applications:

1. Jog the inserter to see if hold-down spring pressure is equal. Any unequal spring pressure will skew material in the jaw.
2. With the feeder already fully loaded and powered On, run the inserter through several cycles.
3. Check material alignment to make sure it is consistent with the grip position (refer back to Section 2, Installing the Machine).

For Bryce 16K base applications:

1. With the feeder already fully loaded and powered On, run several pieces through the Bryce 16K system.
2. Notice transition of material from feeder gate assembly area to the transfer area of the Bryce 16K base. Adjust feeder vertically and horizontally as needed (refer back to Section 2, Installing the Machine).
3. Adjust feeder speed as needed to coincide with transport belt speed.

STEP 6: Final Check

Make sure:

- Leading edge of bottom sheet stops at proper location.
- Proper separation is occurring at gate assembly area.
- Effective preshingling is occurring at curvature of gate assembly.
- Material is not being damaged during cycling.
- Feeder is secured and will not move during operation.

Clearing a Jam

If a jam occurs during operation, follow these steps:

1. Open the discharge safety shield (interlock switch prevents feeder from starting while shield is in the “open” position).
2. Remove jammed product from feeder. While doing so, try to determine the cause of the jam (see Section 5, Operational Troubleshooting).
3. Verify whether any adjustments are loose. If so, refer back to Section 3, Preparing for Operation, for proper adjustment procedures.
4. Close the discharge safety shield and reset the feeder by pressing the reset/fault indicator button (labeled **Reset**).



For inserter applications only: Reposition photo sensor (as required).

Shutdown

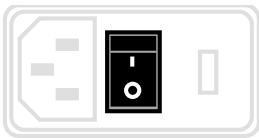

Should you not be using the feeder for long periods of time, follow these steps to ensure safe and secure storage:

1. Turn the feeder power Off by pushing the circle (O) at the rocker **Power** On/Off rocker switch.
2. Disconnect the feeder power cord from the AC power source. *If using the feeder for “continuous mode” applications, disconnect external run input from feeder control panel.*
3. Cover the feeder with a cloth or plastic tarp to prevent dust and debris from accumulating.

5 Operational Troubleshooting

Table 5-1 is intended to provide you with quick solutions to the more common day-to-day problems you may encounter. For additional troubleshooting information, contact a qualified technician.

Table 5-1. Quick-Look Troubleshooting

Problem	Cause	Solution
No AC power to feeder	<ol style="list-style-type: none"> 1. On/Off switch in "Off" (or "O" position). 2. Power cord loose or not plugged into outlet (or AC power source). 3. Female end of power cable loose or not plugged into AC power inlet at rear of feeder. 4. Faulty external run input connection or cable. 5. No voltage is being applied to the external run input connection. 6. Faulty safety interlock switch. 7. Blown fuse. 	<ol style="list-style-type: none"> 1. Check that the switch is pressed to "On" (or "___" position). 2. Check and secure power cord at AC outlet. 3. Check and secure cord at AC power inlet (rear of feeder). 4. Check and secure cable connections. Replace if necessary. 5. Consult with a qualified technician.* 6. Consult with a qualified technician.* 7. Consult with a qualified technician.*
Feeding doubles	<ol style="list-style-type: none"> 1. Gate assembly improperly adjusted (possibly more than one sheet thickness). 2. Back wedge improperly adjusted. 3. Worn O-rings (or if applicable, angled edge). 4. Material interlocking. 5. Static buildup. 	<ol style="list-style-type: none"> 1. Review gate assembly adjustment in Section 3, Preparing for Operation. 2. Review back wedge adjustment in Section 3, Preparing for Operation. 3. Rotate O-rings. Or, if applicable, replace angled edge (see Section 6, Inspection and Care, for procedure). If wear is excessive, consult with a qualified technician.* 4. Check material and source. 5. Check material and source.
Continuous feeding while in presentation mode	<ol style="list-style-type: none"> 1. Possible overlapping. 2. Photosensor not adjusted properly; may be "seeing" background objects. 3. Feeder mode was switched from "continuous" to "presentation" with power supplied to the feeder. 	<ol style="list-style-type: none"> 1. See "Feeding Doubles" above. 2. Review photo sensor adjustment in Section 3, Preparing for Operation. 3. Reset the feeder by pressing the On/Off switch to "Off" (or "O" position) and then back to "On" (or "___" position).
Feeder times out while in continuous mode; continuous alarm sound	<ol style="list-style-type: none"> 1. Feed mode was switched from "presentation" to "continuous" with power supplied to the feeder. 	<ol style="list-style-type: none"> 1. Reset the feeder by pressing the On/Off switch to "Off" (or "O" position) and then back to "On" (or "___" position).
Feed belts are operating, but material not feeding	<ol style="list-style-type: none"> 1. Material stack weight is too low when stack height is down, resulting in reduction of down pressure. 2. Binding in side guides. 	<ol style="list-style-type: none"> 1. Review loading the material in Section 4, How to Operate. 2. Adjust the side guides further apart to allow freedom of movement between sheets.

Table 5-1. Quick-Look Troubleshooting (continued)

Problem	Cause	Solution
Feed belts are operating, but material not feeding (continued)	<ol style="list-style-type: none"> 3. Slippery feed belts (material buildup). 4. Sheet adhesion or interlocking between the bottom and next sheet. 5. Gate assembly may be down too tight. 6. Too much weight in hopper. 	<ol style="list-style-type: none"> 3. Consult with a qualified technician.* 4. Review loading the material in Section 4, How to Operate, or review back wedge adjustment in Section 3, Preparing for Operation. 5. Review gate assembly adjustment in Section 3, Preparing for Operation. 6. Remove material from stack. Test again.
Feed belts not operating; continuous alarm sound	<ol style="list-style-type: none"> 1. Feeder operation was stopped due to a "time-out" fault (i.e., miss, jam, no material in hopper). 	<ol style="list-style-type: none"> 1. Check if reset button/fault indicator is illuminated. Press Reset button.
Feed belts not operating; intermittent alarm sound	<ol style="list-style-type: none"> 1. Discharge safety shield not closed completely. 	<ol style="list-style-type: none"> 1. Check if reset button/fault indicator is blinking. Press Reset button.
Feed belt(s) not tracking on rollers	<ol style="list-style-type: none"> 1. Excessive weight in hopper. 2. Excessive down pressure on gate assembly. 3. Off-centered product from center point of machine. 4. Stack is bearing down on edge of belt. 5. Belt wear. 6. Rollers out of adjustment. 	<ol style="list-style-type: none"> 1. Reduce weight. Test again. 2. Rotate clockwise 1/8 turn to increase gap and manually test. Also, review gate assembly adjustment in Section 3, Preparing for Operation. 3. Review side guides setting in Section 3, Preparing for Operation. 4. Move stack away from belt, even if this causes stack to be aligned off center from center line of feeder. 5. Review gate assembly adjustment and back wedge adjustment in Section 3, Preparing for Operation. Also see Section 6, Inspection and Care. If wear is excessive, consult with a qualified technician.* 6. Consult with a qualified technician.*
Jamming occurs during operation	<ol style="list-style-type: none"> 1. Improper adjustment of any of the following areas: <ol style="list-style-type: none"> a. Gate assembly. b. Back wedge. c. Top roller hold-down assembly. 	<ol style="list-style-type: none"> a. Turn the Power switch to "Off" by pushing the circle ("O"). b. Removed jammed material from feeder. While doing so, try to determine the cause of the jam. c. Verify each adjustment by reviewing Section 3, Preparing for Operation.
Material skewing	<ol style="list-style-type: none"> 1. Back wedge not aligned properly. 2. Hold-down spring tension either too loose or too light. 	<ol style="list-style-type: none"> 1. Review back wedge adjustment in Section 3, Preparing for Operation. 2. Review hold-down spring installation in Section 2, Installing the Machine.
Material too far from gripper jaw (inserter application only)	<ol style="list-style-type: none"> 1. Photo sensor "staging" leading edge of material too far from hopper plate. 2. Gripper jaw adjusted too far from edge of hopper plate. 	<ol style="list-style-type: none"> 1. Review photo sensor adjustment in Section 3, Preparing for Operation. 2. Adjust gripper jaw as required per insert owner's manual.
Material too deep in gripper jaw (inserter application only)	<ol style="list-style-type: none"> 1. Photo sensor "staging" leading edge of material too far past hopper plate. 2. Gripper jaw adjusted too close to edge of hopper plate. 	<ol style="list-style-type: none"> 1. Review photo sensor adjustment in Section 3, Preparing for Operation. 2. Adjust gripper jaw as required per inserter owner's manual.

6 Inspection and Care



When performing initial feeder adjustments prior to operation, always make sure you turn Off the main power switch and disconnect all equipment from the electrical power source. Failure to do so can expose you to a potential startup and moving parts which can cause serious injury.

Do not attempt to make any adjustments while the feeder and machine of application are running. Failure to do so can expose you to moving parts which can cause serious injury. Do not wear loose clothing when operating the feeder.

Avoid making adjustments with loose or unsecured parts. This can potentially damage parts.

Please read this Section to learn how to:

- Visually inspect your machine to detect part problems which may require adjustment or replacement.
- Periodically care for your machine to prevent any operational problems.

Visual Inspection

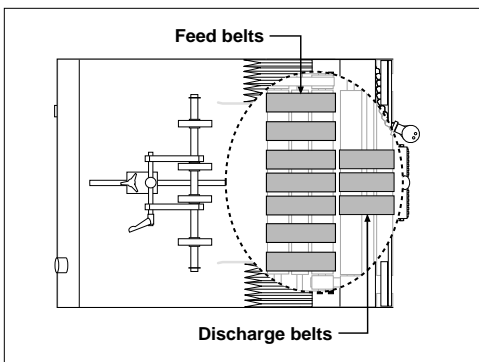

Figure 6-1. Inspecting Feed and Discharge Belts

Checking for Feed and Discharge Belt Wear

Referring to Figure 6-1, check for visual signs of:

- Walking. Replace as required.
- Cracking. Replace as required.
- Thinning. Replace as required.

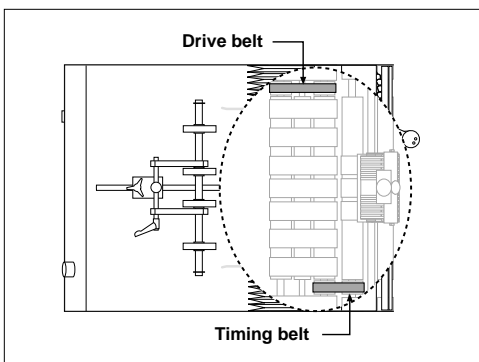

Figure 6-2. Inspecting Timing Belt and Drive Belt

Checking for Timing and Drive Belt Wear

Referring to Figure 6-2, check for visual signs of:

- Fraying. Replace as required.
- Missing teeth. Replace as required.
- Cracking. Replace as required.
- Paper residue buildup. Clean from belts, especially in grooves.

Visual Inspection (continued)

Ensuring Proper Feed and Discharge Belt Tracking

Referring to Figure 6-3, check for visual signs of:

- Stretching.
- Improper roller adjustment.

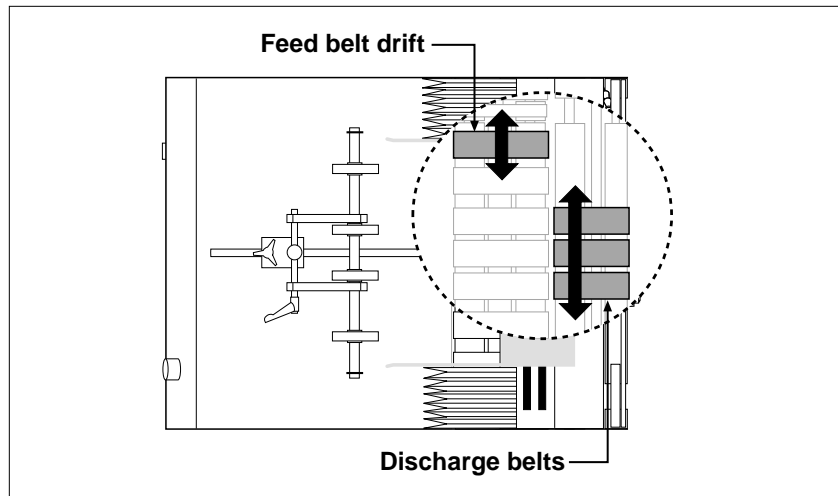

Figure 6-3. Ensuring Proper Feed Belt Tracking

Ensuring Proper Timing and Drive Belt Tracking

Referring to Figure 6-4, check for visual signs of:

- Misaligned timing pulleys.

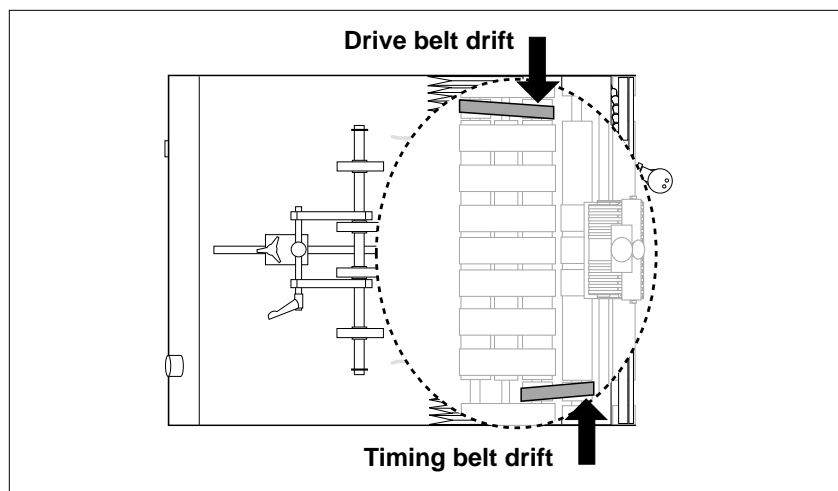

Figure 6-4. Ensuring Proper Drive Belt Tracking

Visual Inspection (continued)

Checking for Gate Assembly Wear

Check for visual signs of wear:

- Advancing O-ring, or Standard O-ring: Flat areas along the O-rings (Figures 6-5 and 6-6, respectively).
- Bar Gate: Angled wedge begins to flatten excessively (Figure 6-7).

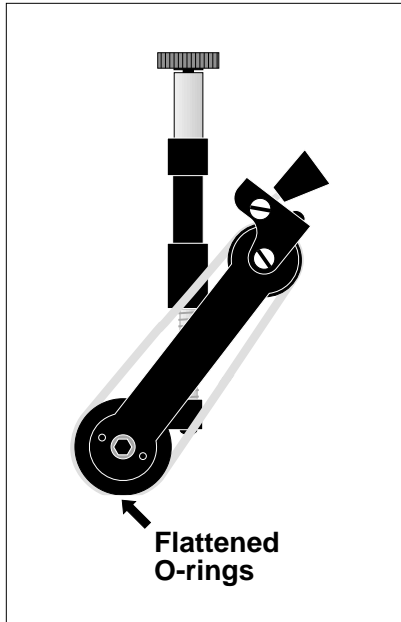

Figure 6-5. Advancing O-Ring Gate

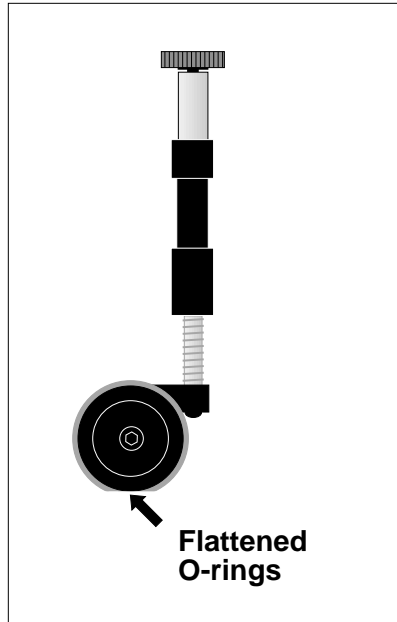

Figure 6-6. Standard O-Ring Gate

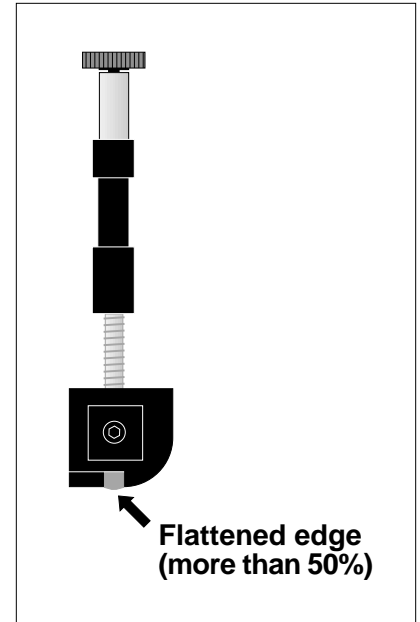

Figure 6-7. Bar Gate

Visual Inspection (continued)

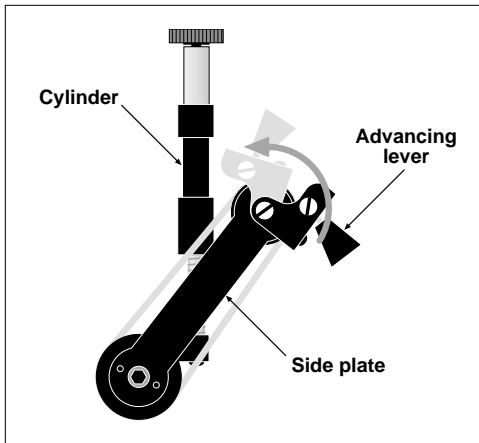

Figure 6-8. Advancing O-Ring Gate

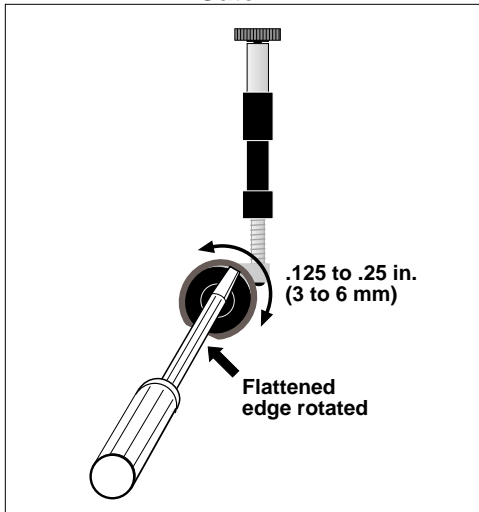

Figure 6-9. Standard O-Ring Gate

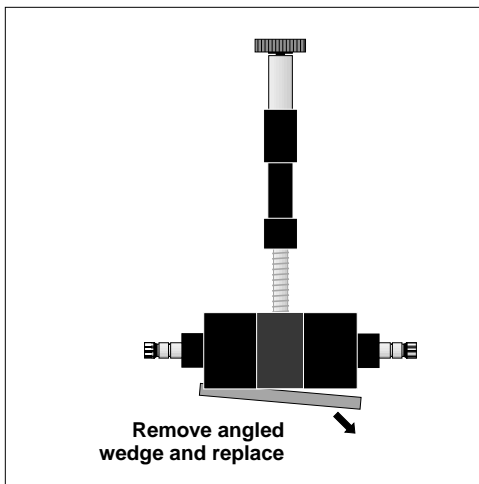

Figure 6-10. Bar Gate

Advancing O-Ring Gate: Adjusting Worn O-Rings

To adjust worn O-rings on advancing O-ring gate (Figure 6-8):

1. Turn Off feeder and remove power cord from outlet.
2. Open discharge safety shield to access gate.
3. Make sure advance knob is in-line with the side plate and secure. Then loosen left and right locking wing nuts.
4. Rotate O-rings by grasping advance knob and pushing towards gate cylinder about .125 to .25 in. (3 to 6 mm).
5. Retighten locking wing nuts. Then loosen advance knob and move to original position (in-line with side plate). Retighten.
6. Close discharge safety shield and restore power.

Standard O-Ring Gate: Adjusting Worn O-Rings

To adjust worn O-rings on standard O-ring gate (Figure 6-9):

1. Turn Off feeder and remove power cord from outlet.
2. Open discharge safety shield to access gate.
3. Remove gate assembly from gate plate.
4. Insert a screwdriver in slot on top of gate assembly and rotate screwdriver clockwise or counter-clockwise 360° so as to move worn area of O-ring about .125 to .25 in. (3 to 6 mm).
5. Remove screwdriver and repeat for each ring as necessary.
6. Reinstall gate assembly, close discharge safety shield, and restore power.

Replacing Worn Angled Wedge

To replace a worn angled wedge (Figure 6-10):

1. Turn Off feeder and remove power cord from outlet.
2. Open discharge safety shield to access gate.
3. Remove gate assembly from gate plate.
4. Remove plate (two screws).
5. Remove angled wedge.
6. Install new angled wedge. Reinstall plate (two screws).
7. Reinstall gate assembly, close discharge safety shield, and restore power.

Preventive Care



Use only isopropyl alcohol (98% concentration). Other solvents can cause belts to wear prematurely, and even cause total breakdown of material.

Cleaning schedule for various materials:

- *Typical: every month*
- *Dusty: after every shift*
- *High ink or varnish: 1 time per shift*

Cleaning Feed and Discharge Belts

To clean feed belts (Figure 6-11):

1. Turn Off feeder and remove power cord from outlet.
2. Open discharge safety shield.
3. Remove gate assembly from gate plate for easier access to belts.
4. Apply a small amount of isopropyl alcohol to a soft cloth.
5. Use your hand to move the feed belt, start with one feed belt at a time and carefully press the moistened area of the cloth to the belt. As you rotate the belt, use moderate pressure to wipe across the belt, making sure to wipe in direction of grooves. After several rotations of the belt, repeat for each belt.
6. Taking a dry portion of the cloth, go back to the first feed belt cleaned and use moderate pressure against the belt for several revolutions to ensure the belt is dried. Repeat for each belt.
7. Reinstall gate assembly, close discharge safety shield, and restore power.

To clean discharge belts (Figure 6-12):

1. Turn Off feeder and remove power cord from outlet.
2. Open discharge safety shield.
3. To access discharge belts, move top roller hold-down assembly away from discharge belts by loosening two T-nuts on either side of shaft. Lift up on top roller assembly.
4. Repeat steps 4-6 above. Repeat for each belt.
5. Reinstall gate assembly, return roller hold-down assembly to original position, close discharge safety shield, and restore power.

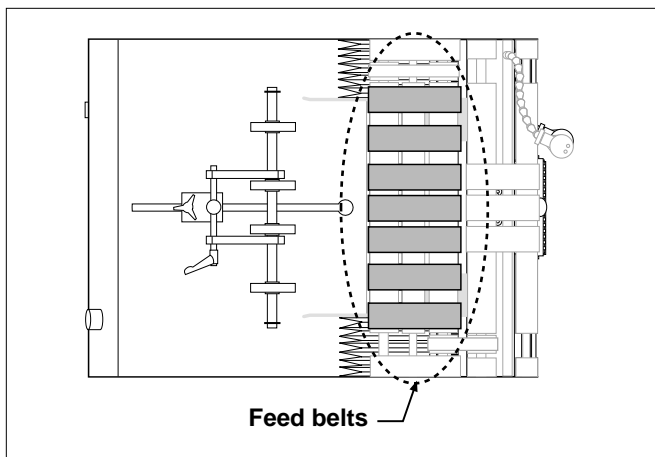

Figure 6-11. Cleaning Feed Belts

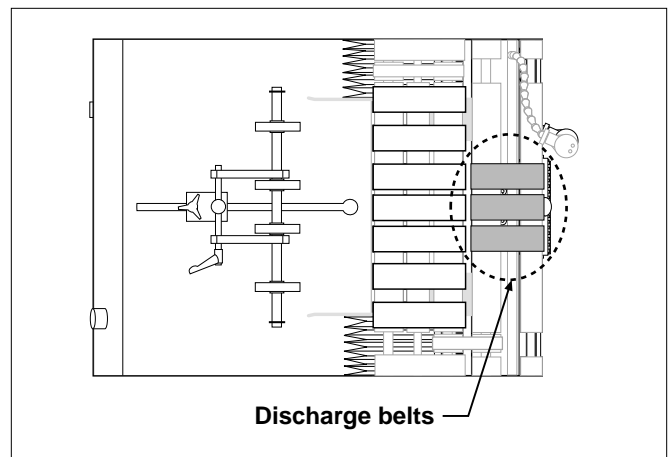

Figure 6-12. Cleaning Discharge Belts

Preventive Care (continued)

NOTE

Depending on the application, it may be necessary to move the feeder from original installation so as to access gate assembly.

Cleaning schedule for various materials:

- Typical: every month
- Dusty: after every shift
- High ink or varnish: 1 time per shift

Cleaning Gate Assembly

Use only isopropyl alcohol (98% concentration). Do not use any other types of solvents. They can cause premature wear of the belts, or even total breakdown of the material.

To clean gate assemblies:

1. Turn Off feeder and remove power cord from outlet.
2. Open discharge safety shield to access gate.
3. Remove gate assembly from gate bracket assembly.
4. Apply a small amount of isopropyl alcohol to a soft cloth.
5. Wipe across O-rings (Figures 6-13 or 6-14), or angled wedge if applicable (Figure 6-15). First wipe in one direction, then the other.
6. Taking a dry portion of the cloth, go back and wipe all surfaces to ensure they are dried.
7. Reinstall gate assembly, close discharge safety shield, and restore power. *It may be necessary to recheck alignment of feeder with host machine if feeder was moved from original installation position (for a review, refer back to Section 2, Installing the Machine).*

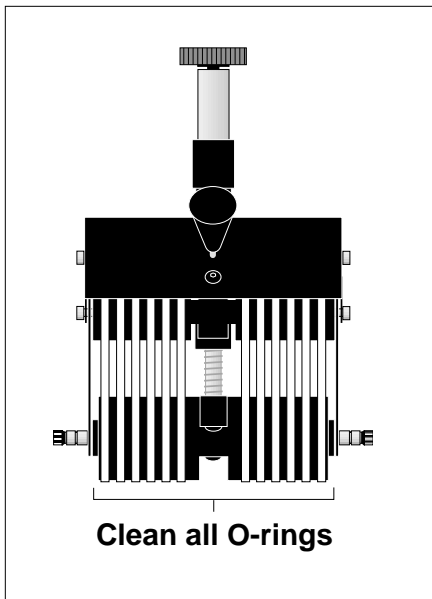

Figure 6-13. Advancing O-Ring Gate

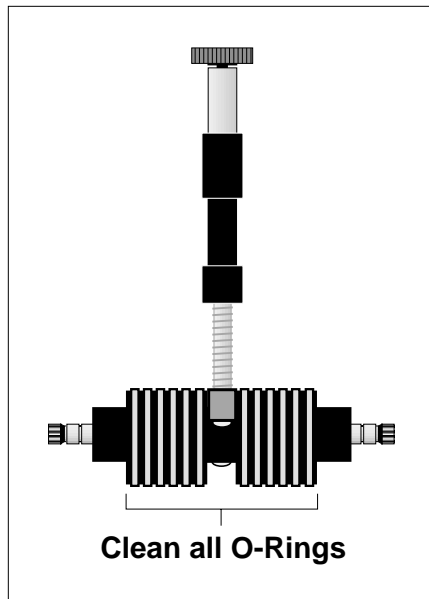

Figure 6-14. Standard O-Ring Gate

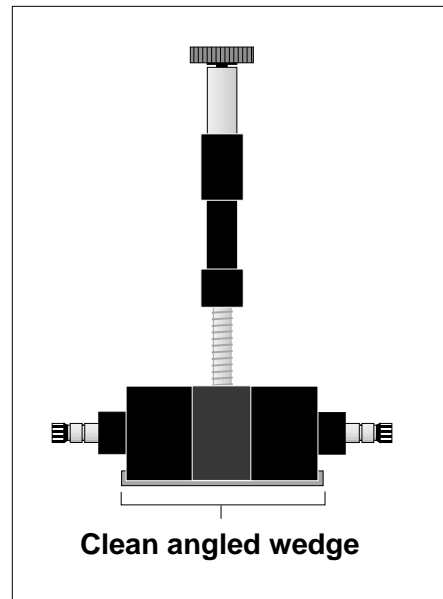

Figure 6-15. Bar Gate

Preventive Care (continued)



Do not use any solvents or cleaning agents when cleaning the photo sensor lens. This can result in surface damage and eventual faulty performance.

Cleaning Photo Sensor (Inserter Applications Only)

To clean the photo sensor lens:

1. Turn Off feeder and remove power cord from outlet.
2. Open discharge safety shield to access photo sensor.
3. Using a soft, dry cloth, wipe across the face of the photo sensor lens (Figure 6-16).
4. Recheck the adjustments to make sure it is still in alignment to the target (for a review, refer back to Section 3, Preparing for Operation).
5. Close discharge safety shield and restore power.

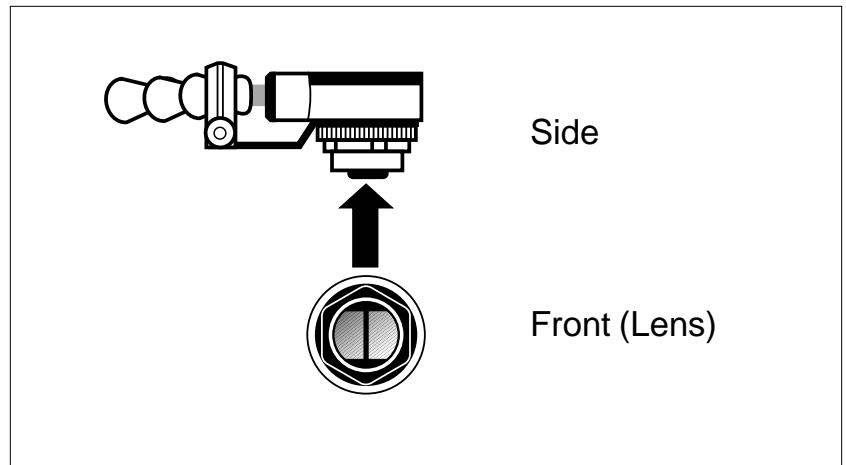

Figure 6-16. Cleaning Photo Sensor

7 Additional Wedges

This section provides information about setting up various wedges which are optional with the Reliant 2600/2700 Universal Friction Feeders.

Now that you are familiar with the basic principles of using a wedge, it is simply a matter of combining these principles with the information provided in this Section. This will allow you to get optimum performance when setting up the wedge included with your particular feeder.

The following wedges are covered:

- Load compensating
- Articulating roller
- Extended narrow
- Combination triangle and low-profile
- Separate triangle and low-profile
- Separate articulating roller and low-profile

Load Compensating

When to use: Effective for moderately thick material. Due to characteristics of material, no mid-range support is required.

Setup guidelines: Adjust so the top angle of wedge preshingles the stack against curvature of gate assembly. Edges of material should not extend beyond the tip of wedge. Ideal separation should be: as the stack moves down the wedge, 3 or 4 sheets of material separate out and come to rest on lower angle of wedge. Then, 3 or 4 sheets of material fall to table top, which are then replaced with another 3 or 4 sheets from stack above (Figure 7-1).

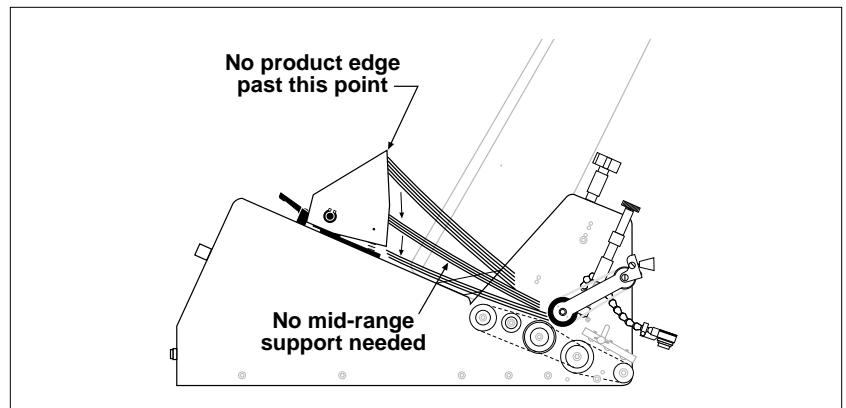
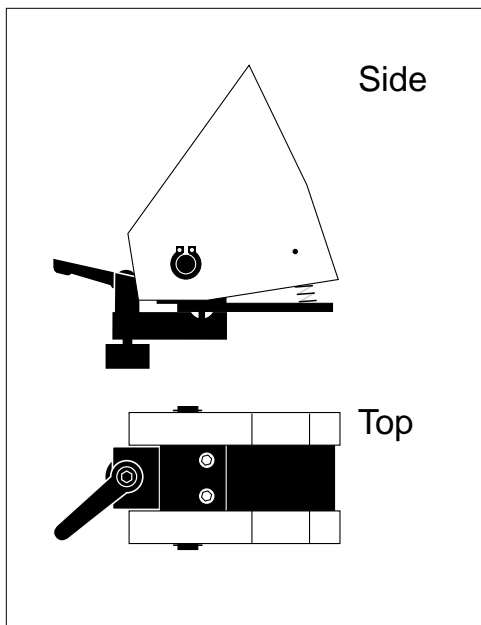
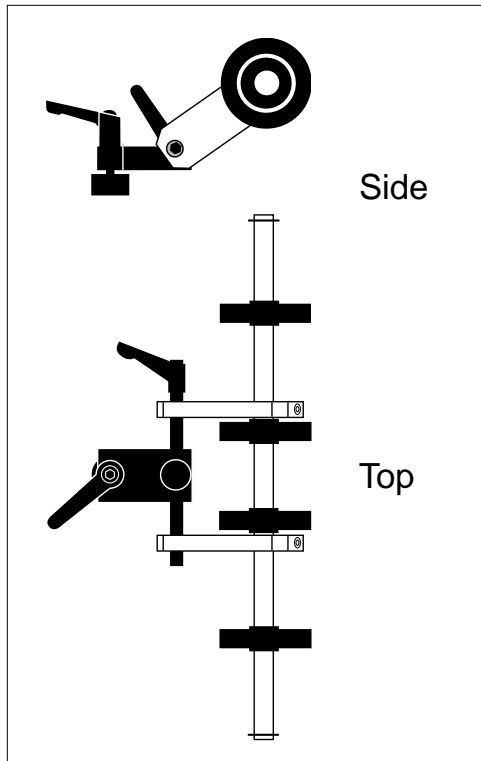

Figure 7-1. Load Compensating Wedge Setup

Articulating Roller



When to use: Effective for very thick and/or ridged material. Due to characteristics of material, no mid-range support is required.

Setup guidelines: Adjust so that roller edges preshingle the stack against the curvature of gate assembly. Again, make sure edges of material do not extend back more than the mid-point of roller (Figure 7-2). *Note: With some material that tends to bind together (for example, perforated material), it may be beneficial to separate 4 to 5 sheets of material at the bottom to provide some air space.*

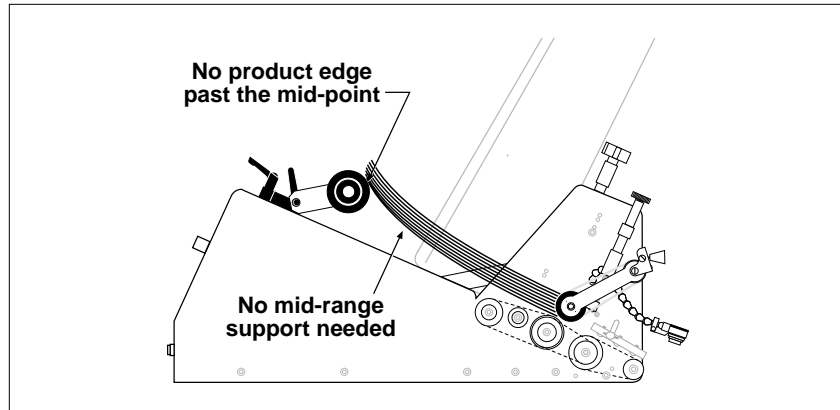
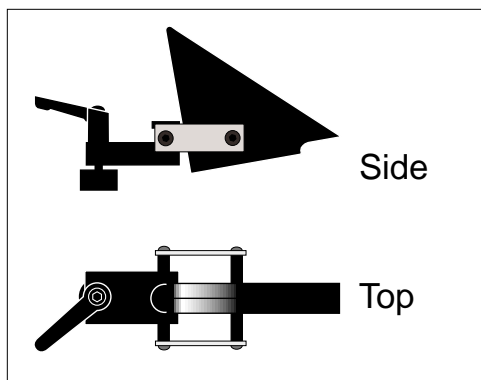

Figure 7-2. Articulating Roller Wedge Setup

Extended Narrow



When to use: Effective for moving in close to the gate assembly for supporting very small material. Due to characteristics of material, no mid-range support is required.

Setup guidelines: Adjust so that wedge preshingles the bottom of stack against the curvature of gate assembly. Make sure edges of material do not extend back more than the mid-point of wedge (Figure 7-3).

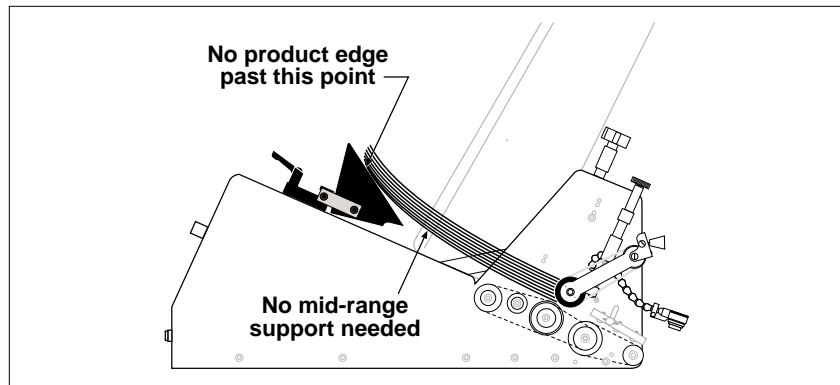
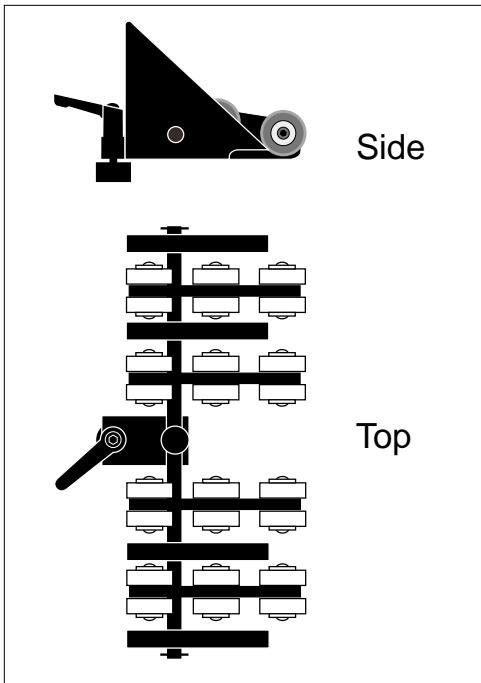

Figure 7-3. Extended Narrow Wedge Setup

Combination Triangle and Low-Profile



When to use: For thin material with minimal body, thus requiring minimal mid-range support.

Setup guidelines: Adjust so that bottom of stack preshingles against the curvature of gate assembly, making sure edges of material do not touch or overhang tips of triangle wedges, as this creates pressure points. Roller(s) should lift bottom of stack off table top to eliminate friction and create body (Figure 7-4).

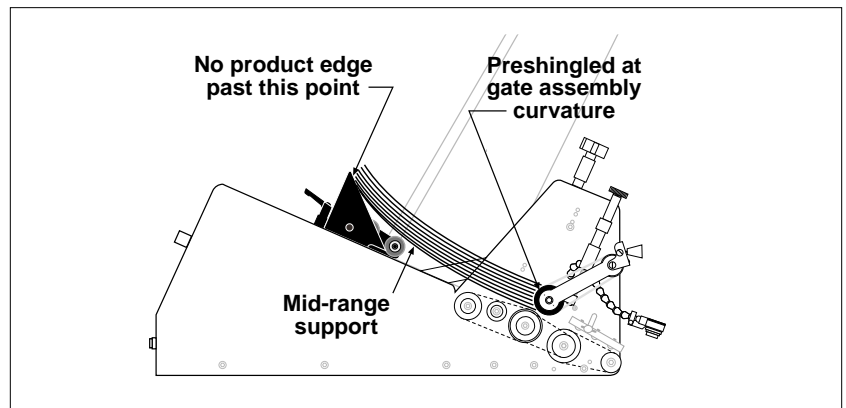
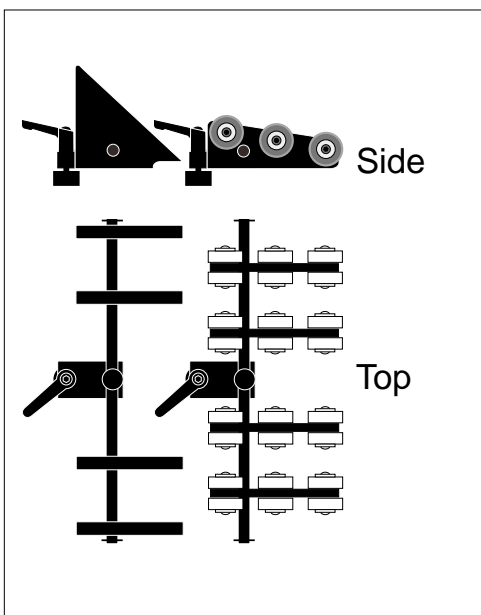

Figure 7-4. Combination Triangle/Low-Profile Wedge Setup

Separate Triangle and Low-Profile



When to use: If moving separate triangle wedge assembly back from the gate assembly, bottom of stack still touches table top. This means you need mid-range support.

Setup guidelines: Adjust the triangle wedge the same way you would the combined triangle/low-profile wedge assembly (see above). Set the low-profile wedge relative to the triangle wedge so it lifts bottom of the stack off the table top to eliminate friction and create body. Make sure edges of material do not touch or overhang tips of triangle wedges, as this creates pressure points (Figure 7-5).

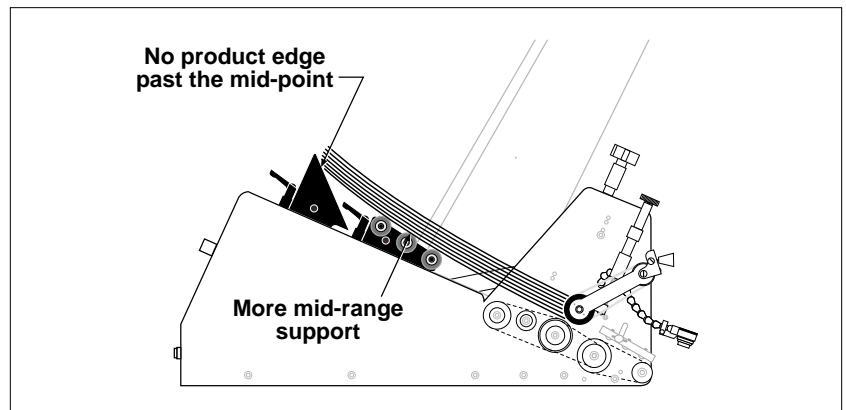
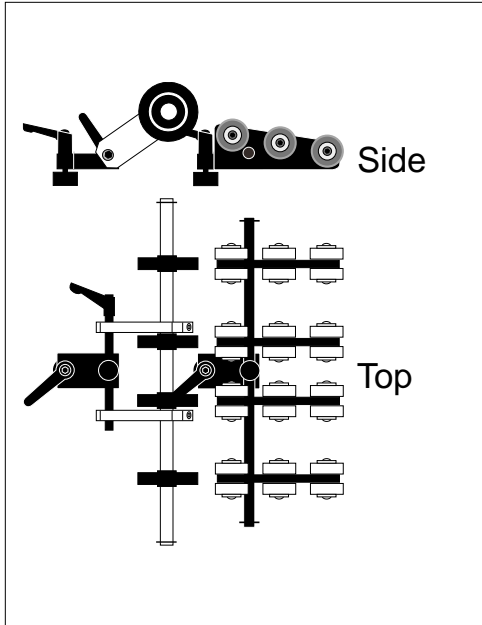

Figure 7-5. Separate Triangle and Low-Profile Wedge Setup

Separate Articulating Roller and Low-Profile



When to use: For thicker material with more body, thus requiring medium mid-range support. Longer material may also benefit.

Setup guidelines: Initially adjust articulating wedge so that roller edges preshingle the bottom of the stack against the curvature of gate assembly. Make sure edges of material do not extend back more than mid-point of rollers (Figure 7-6). Set the low-profile wedge so roller(s) lift bottom of stack off the table top to eliminate friction and create body.

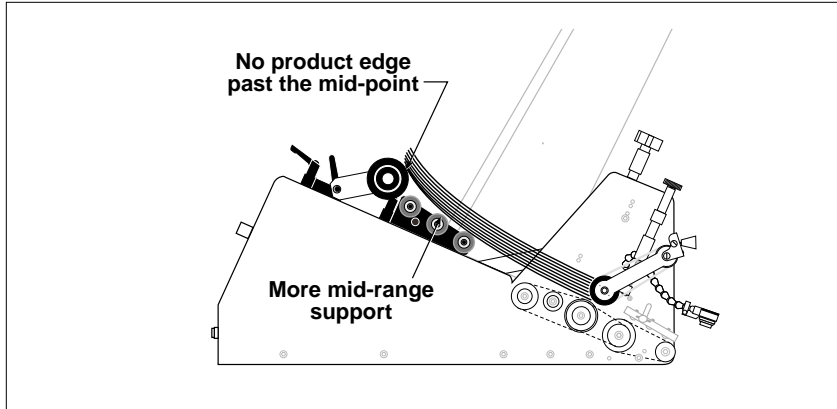
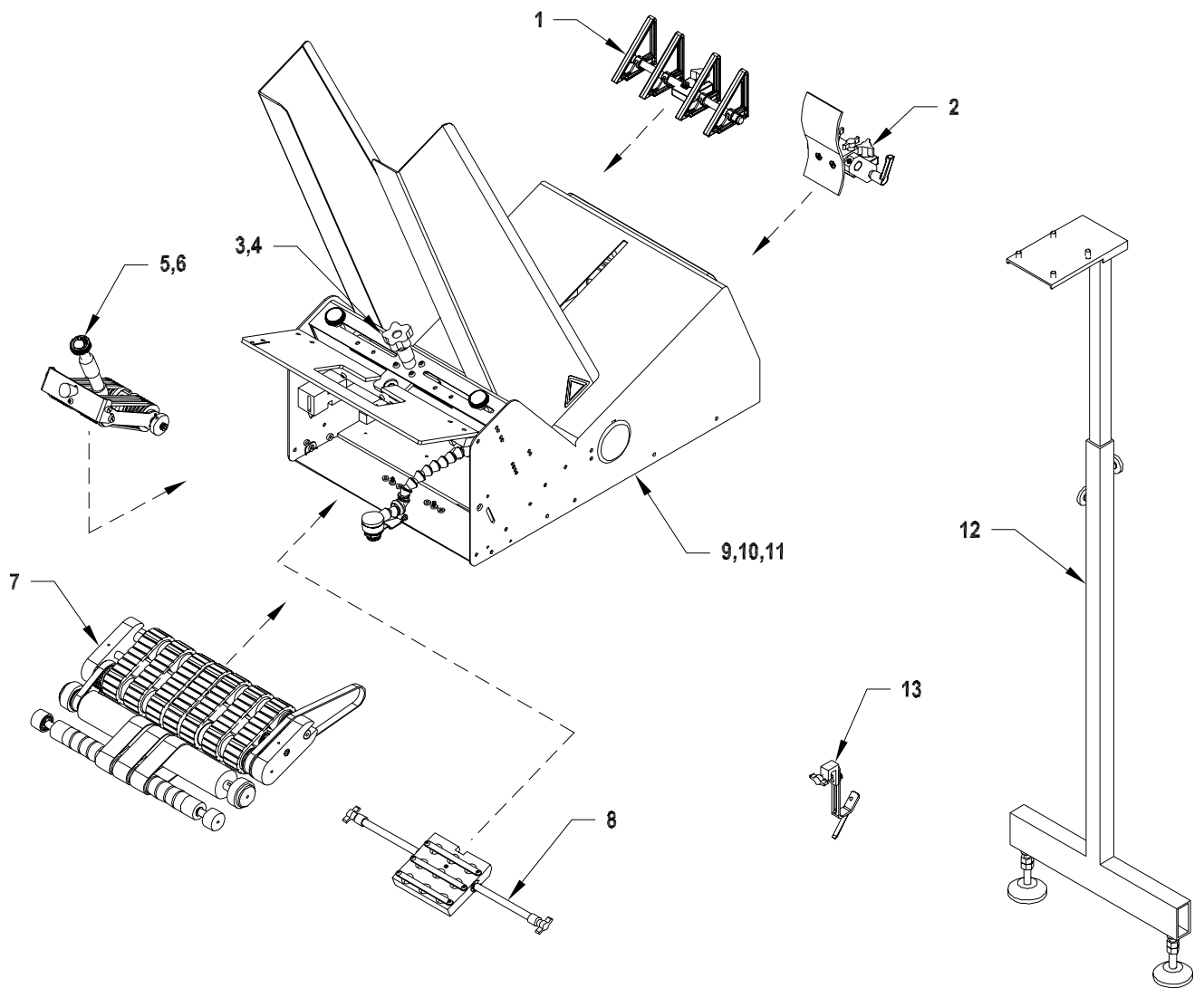

Figure 7-6. Separate Articulating Roller and Low-Profile Wedge Setup

8 Mechanical Components



1: TRIANGLE WEDGE ASSEMBLY #63311214

NOTE: THIS ASSEMBLY IS STANDARD ONLY ON PRESENTATION MODE FEEDERS

<u>DIAGRAM NUMBER</u>	<u>QTY</u>	<u>DESCRIPTION</u>	<u>PART NUMBER</u>
1-1	1	Wedge Guide Shaft	44633018
1-2	1	SHCS 10-32 X 5/8" LG	00002320
1-3	1	Wedge Block	44633014
1-4	1	T-Nut Round	44633016
1-5	1	Knob 3 Lobe 10-32 X 5/8" LG	44633033
1-6	2	Ring Grip 3/8 Waldes	00001110
1-7	4	Wedge Material Support	43560212
1-8	1	Short Triangle Wedge	63311017
	(2)	(Ring Grip 3/8 Waldes)	(00001110)
	(2)	(Wedge Material Support)	(43560212)
	(1)	(Shaft Wedge Guide)	(44633017)

NOTE: THIS ASSEMBLY IS STANDARD ONLY ON PRESENTATION MODE FEEDERS

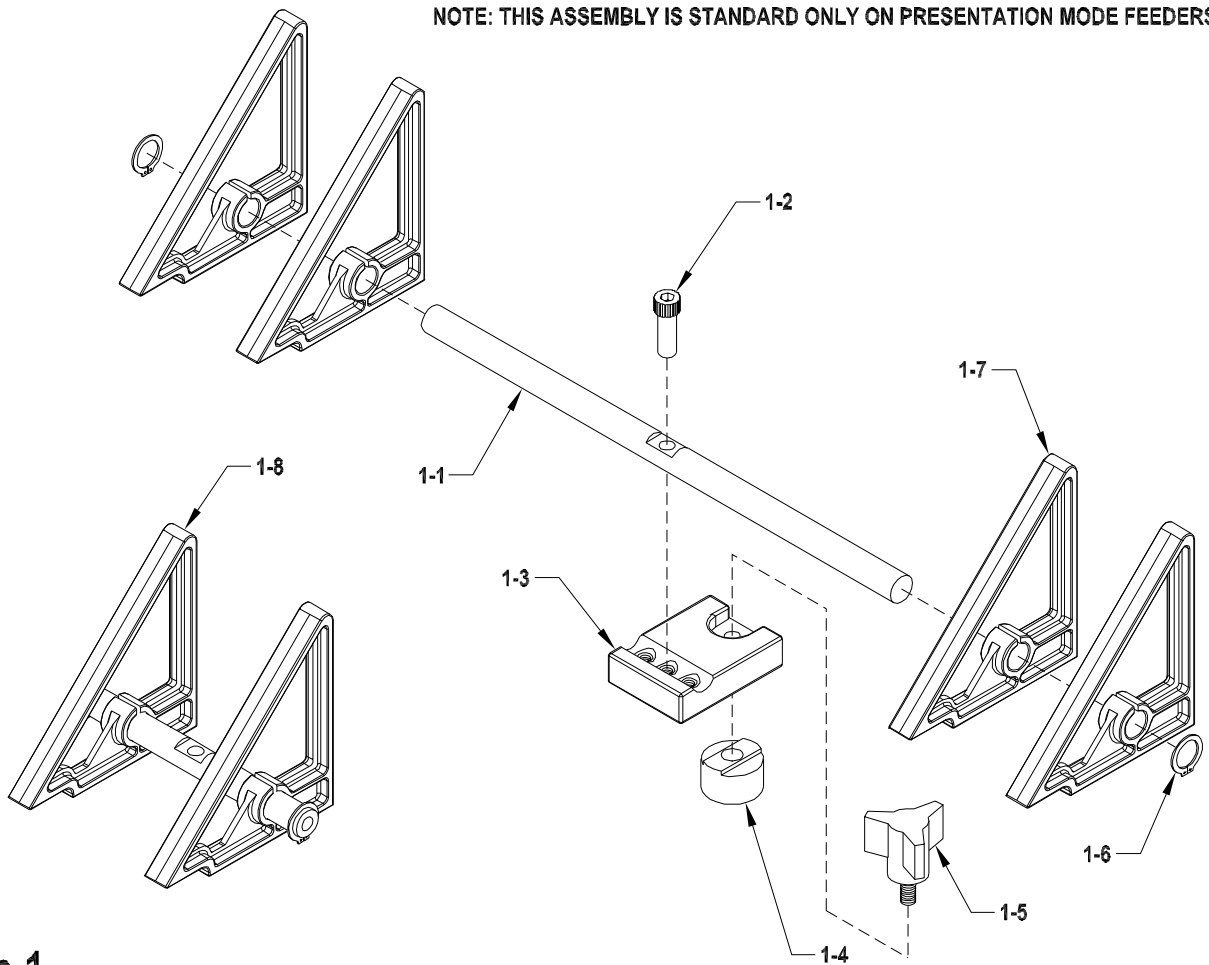

Diagram 1
Triangle Wedge
Assembly #63311214

2: SINGLE S WEDGE ASSEMBLY #63311026

NOTE: THIS ASSEMBLY IS STANDARD ONLY ON CONTINUOUS & DUAL MODE FEEDERS

<u>DIAGRAM NUMBER</u>	<u>QTY</u>	<u>DESCRIPTION</u>	<u>PART NUMBER</u>
2-1	2	Knob Wing #10 w/o Screw	23500076
2-2	2	SHCS 10-32 X 1" LG	00002335
2-3	1	S Wedge	44633025
2-4	2	Screw Flat Head 10-32 X 1/2" LG	00002330
2-5	2	Spacer .25 X .375 Tapped 10-32	44633027
2-6	2	Screw Socket Set 1/4-20 X 1/4" LG	00002205
2-7	1	Block Mounting	44633026
2-8	1	Shaft Pivot Block	44633028
2-9	2	Adjustment Clamping Handle 1/4-20 X .63	44340015
2-10	2	Bracket Roller Wedge Pivot	43500165
2-11	1	SHCS 10-32 X 5/8" LG	00002320
2-12	1	Shaft Wedge Guide	44633032
2-13	1	Knob 3 Lobe 10-32 X 5/8	44633033
2-14	1	Wedge Block	44633014
2-15	1	T-Nut Round	44633016

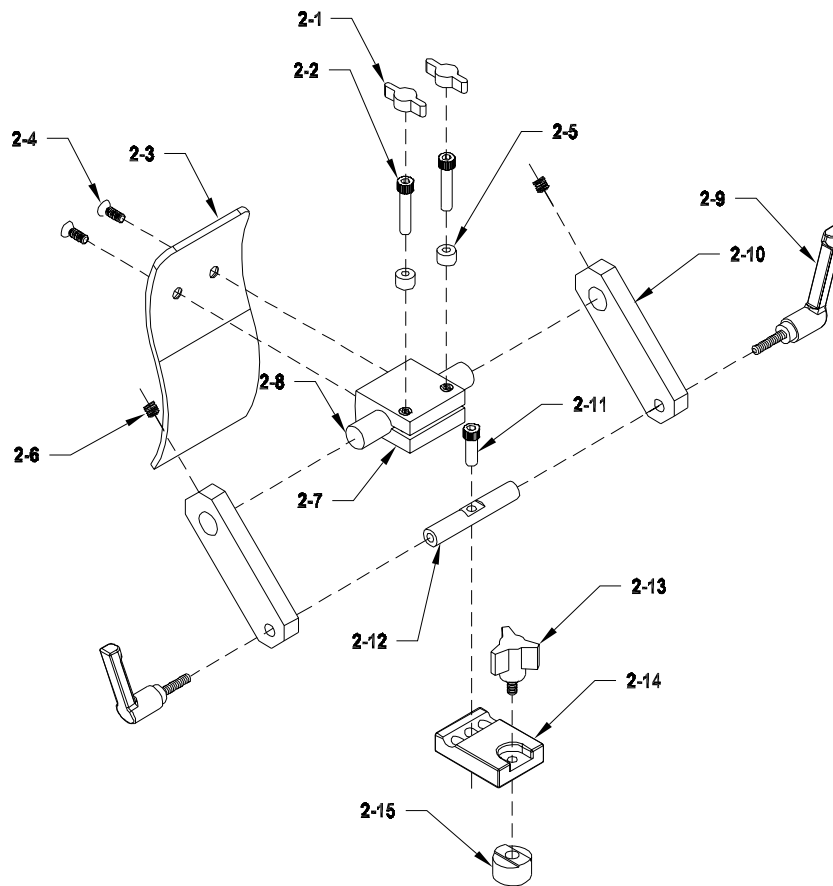

Diagram 2
 Angle S Wedge
 Assembly #63311026 REV A

3: 2 KNOB GATE PLATE

ASSEMBLY #69211011 (2600) OR #67511011 (2700)

NOTE: THIS ASSEMBLY IS STANDARD ONLY ON PRESENTATION MODE FEEDERS

<u>DIAGRAM NUMBER</u>	<u>QTY</u>	<u>DESCRIPTION</u>	<u>P/N 2600</u>	<u>P/N 2700</u>
3-1	2	Lever Adjustment 10-32 X .75	43555098	43555098
3-2	2	Clamp Side Adjust	44675006	44675006
3-3	1	Bar Lower Gate Support	44642022	44675008
	2	Hook Gate J	15000007	15000007
	2	SHCS 8-32 X 5/8" LG	00002215	00002215
3-4	1	Bar Upper Gate Support	44642021	44675009
3-5	2	Block Side Guide Mount	44675007	44675007
3-6	1	Bar Pre Gate	44642019	44675010
3-7	1	Pre Gate	44642020	44675011
	4	Screw Flat Head 10-32 X 1/2" LG SS	00002830	00002830
3-8	1	Block Adjustment Reference	15000003	15000003
3-9	2	SHCS 8-32 X 5/8" LG	00002215	00002215

NOTE: THIS ASSEMBLY IS STANDARD ONLY ON PRESENTATION MODE FEEDERS

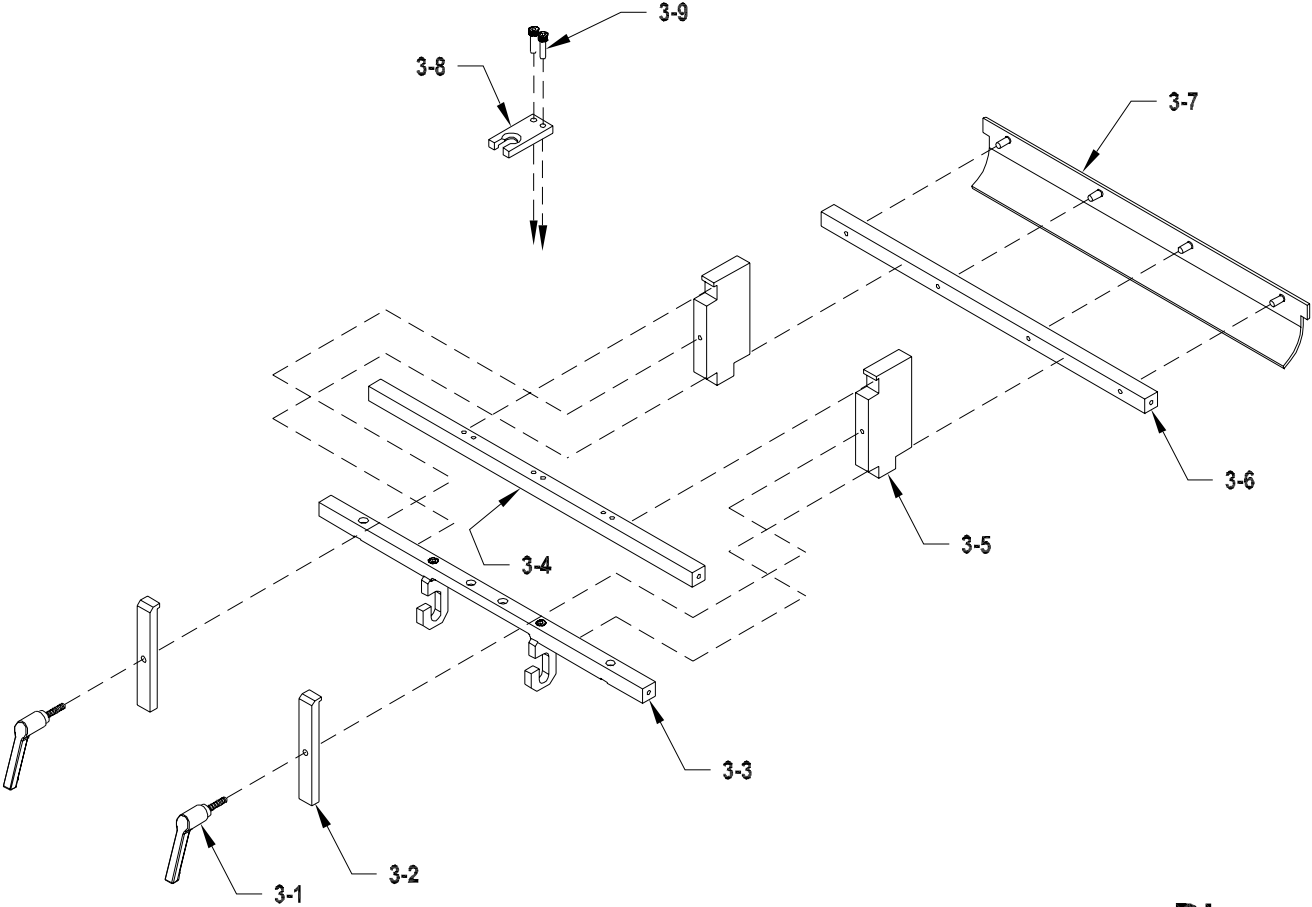

Diagram 3

2 Knob Gate Plate
Assy #69211011 (2600)
Assy #67511011 (2700)

4: 1 KNOB SOLID GATE PLATE ASSEMBLY #69211004 (2600) OR #64011004 (2700)

NOTE: THIS ASSEMBLY IS STANDARD ONLY ON CONTINUOUS & DUAL MODE FEEDERS

<u>DIAGRAM NUMBER</u>	<u>QTY</u>	<u>DESCRIPTION</u>	<u>P/N 2600</u>	<u>P/N 2700</u>
4-1	1	Guide Adjustment Cover Side	44692015	44646012
	4	BHCS 10-32 X 3/8" LG	00002805	00002805
4-2	1	Gate Support Bar Lower	44692011	44646003
	2	Hook Gate J	15000007	15000007
	2	SHCS 8-32 X 5/8" LG	00002215	00002215
4-3	2	Rail Side Guide Support	44692013	44646006
4-4	2	Guide Adjustment Block	44646001	44646001
	4	Screw Socket Set 1/4-20 X 1/4"	00002205	00002205
4-5	1	Guide Stationary Block Side	44646002	44646002
4-6	4	Rack	44692014	44646010
4-7	2	Spacer Lower	44646015	44646015
4-8	1	Block Adjustment Reference	44646004	44646004
	4	BHCS 10-32 X 3/8" LG	00002805	00002805
4-9	1	Shaft Pinion Adjustment	44646005	44646005
4-10	1	Solid Gate Plate	44692012	44640004
4-11	4	Screw Flat Head 10-32 X 3/8" LG	00002234	00002234
4-12	2	Knob Plastic 10-32 w/o Screw	44681021	44681021
	2	Screw Socket Set 10-32 X 1 1/2" LG	00003313	00003313
	2	Spacer Upper	44646016	44646016
4-13	1	Knob 5 Lobe	44646009	44646009
	1	Spring Retainer Upper	44646008	44646008
	1	Spring Retainer Lower	44646007	44646007
	1	Spring Compression	44646013	44646013
4-14	2	Screw Flat Head 10-32 X 1/2" LG	00002830	00002830

**NOTE: THIS ASSEMBLY IS STANDARD ONLY ON
CONTINUOUS & DUAL MODE FEEDERS**

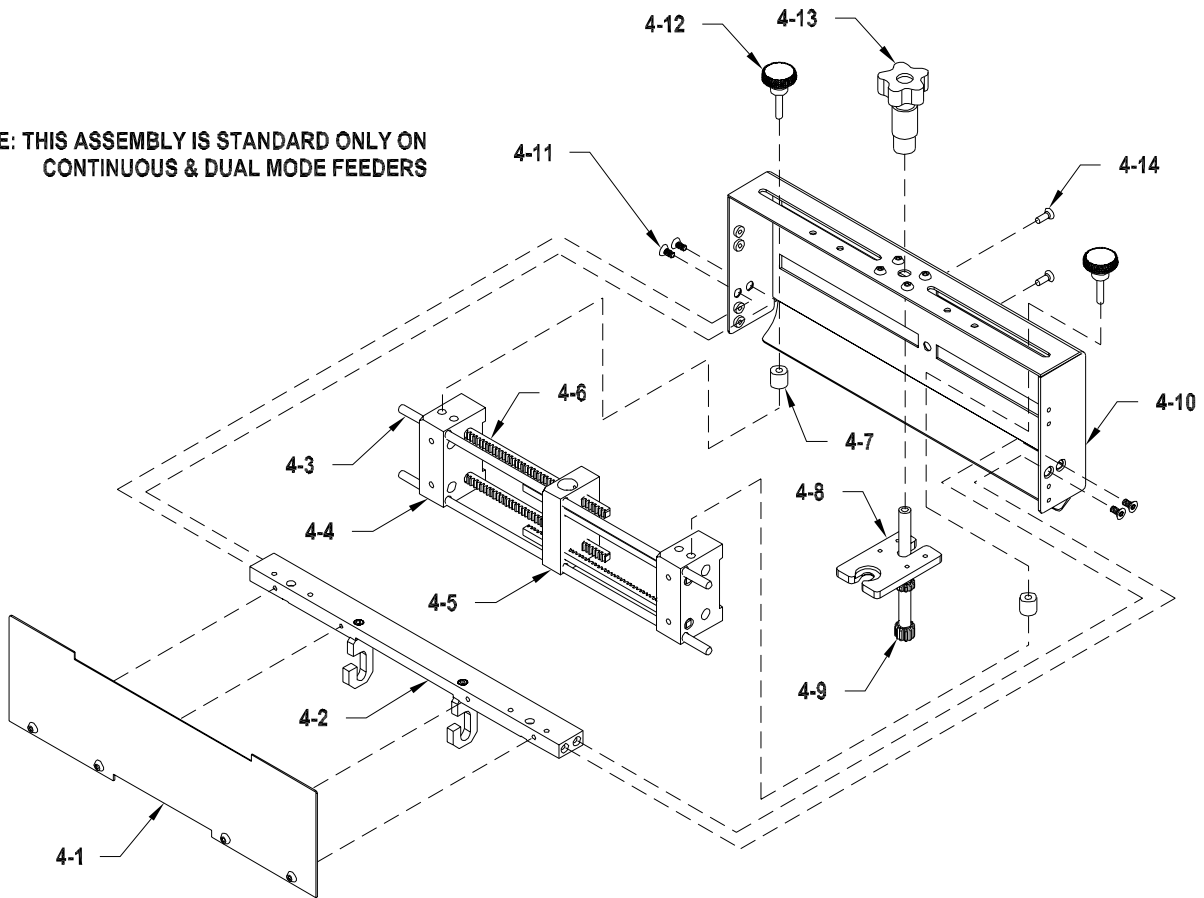
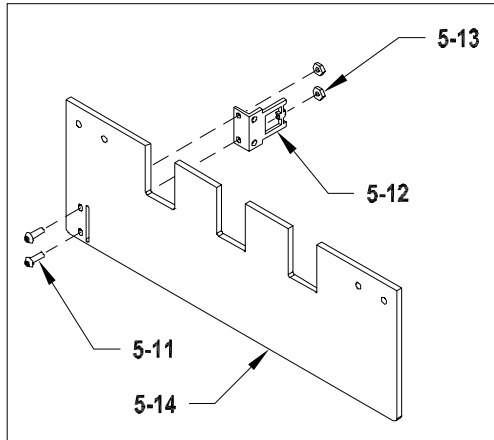

Diagram 4
1 Knob Solid Gate Plate
Assy #69211004 (2600)
Assy #64011004 (2700)

**5: STANDARD O-RING GATE
W/HORIZON ADJUST & COVER
ASSEMBLY #69211020 (2600) OR #67511020 (2700)**

NOTE: THIS ASSEMBLY IS STANDARD ONLY ON PRESENTATION MODE FEEDERS

<u>DIAGRAM NUMBER</u>	<u>QTY</u>	<u>DESCRIPTION</u>	<u>PART NUMBER</u>
5-1	1	Adjustment Knob Assembly for Gate	23511037
5-2	1	Cylinder Gate Spring Tension	23500019
5-3	1	Shaft Gate Lift	23560084
	1	Spring Gate Compression	23500083
5-4	1	Mount Gate Lift Shaft	15000001
5-5	1	BHCS 10-32 X 1/2" LG	00002334
5-6	2	Screw	44872005
5-7	12	O Ring Gate Cylinder	23500089
5-8	1	BHCS 10-32 X 1" LG	00002340
	1	Washer Flat #10	00002607
5-9	1	Gate Cylinder w/Horizon (Not Sold Separately)	51101001
	2	Screw Socket Set 10-32 X 1/4" LG Cup Pt	00002216
5-10	2	Roller	44872003
	2	Screw Socket Set 10-32 X 3/8" LG Nylon Tip	44872007
5-11	2	BHCS 8-32 X 1/2" LG	00002302
5-12	1	Key Safety Interlock	44649010
5-13	2	Nut Keps 8-32 Zinc	00002121
5-14	1	Cover Protective Standard Gate	44692009 (2600) 44675013 (2700)



NOTE: Gate assy with out cover is P/N 13511872

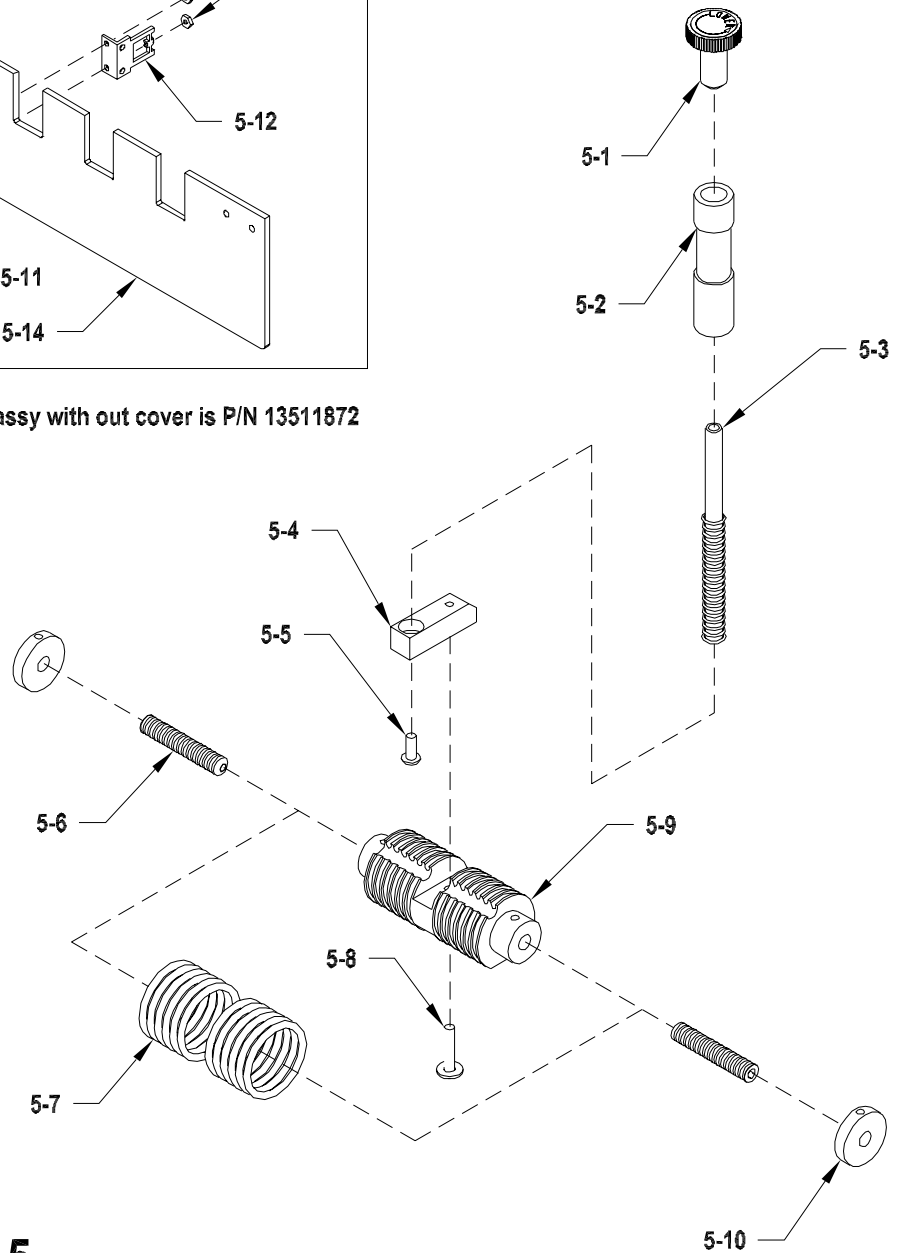

Diagram 5

Standard O Ring Gate
w/Horizon Adjust & Cover
Assy #69211020 (2600)
Assy #67511020 (2700)

**NOTE: THIS ASSEMBLY IS STANDARD ONLY ON
PRESENTATION MODE FEEDERS**

6: ADVANCING O-RING GATE w/HORIZON ADJUST & COVER

ASSEMBLY #69211007 (2600) OR #67511028 (2700)

NOTE: THIS ASSEMBLY IS STANDARD ONLY ON CONTINUOUS & DUAL MODE FEEDERS

<u>DIAGRAM NUMBER</u>	<u>QTY</u>	<u>DESCRIPTION</u>	<u>PART NUMBER</u>
6-1	1	Handle Studded 10-32 X 1/2"	44657007
6-2	1	BHCS 8-32 X 1/2" LG	00002302
6-3	1	Spacer Belt Indexer .312 X .375	44657010
6-4	2	Screw Shoulder 8-32 Slotted	00003320
6-5	2	Screw Shoulder 8-32 Slotted	00003321
6-6	1	Belt Indexer Bracket	44657005
6-7	1	Pinch Roll Cam	44657003
6-8	1	Belt Indexer Shaft	44657008
	2	O Ring Take Up Roller	44657002
	1	Belt Indexer Center Hub	44657009
	2	Clip E 1/2 Waldes	00001155
	2	Screw Socket Set 8-32 X 5/16 Cup Point	00002211
6-9	2	Roller	44872003
	2	Adjustment Screw	44872005
	2	Screw Socket Set 10-32 X 3/8" LG Nylon Tip	44872007
6-10	12	O Ring Advancing	44657006
6-11	2	Side Plate Adjust	44872002
6-12	4	Pin Roll 1/8 X 1/2	00001161
6-13	1	BHCS 10-32 X 1" LG	00002340
6-14	1	Gate Cylinder w/Horizon (Not Sold Separately)	44872004
6-15	1	BHCS 10-32 X 1/2" LG	00002334

<u>DIAGRAM NUMBER</u>	<u>QTY</u>	<u>DESCRIPTION</u>	<u>PART NUMBER</u>
6-16	1	Mount Gate Lift Shaft	15000001
6-17	1	Shaft Gate Lift	23560084
	1	Spring Gate Compression	23500083
6-18	1	Cylinder Gate Spring Tension	23500019
6-19	1	Adjustment Knob Assembly for Gate	23511037
6-20	2	BHCS 8-32 X 1/2" LG	00002302
6-21	1	Key Safety Interlock	44649010
6-22	2	Nut Keps 8-32	00002121
6-23	1	Cover Advancing Gate Protective	44692007 (2600) 44675028 (2700)

NOTE: Gate assy without cover is P/N 87211001

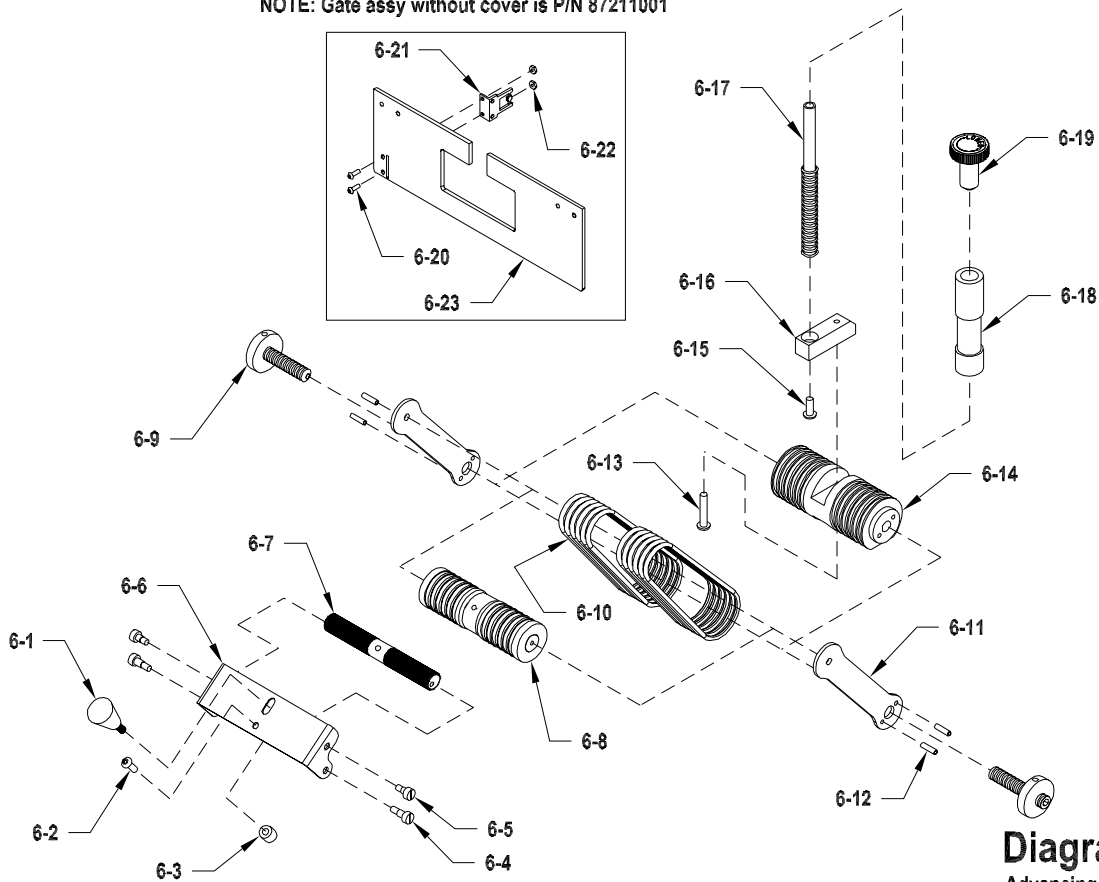

Diagram 6

Advancing O Ring Gate
w/ Horizon Adjust & Cover
Assy #69211007 (2600)
Assy #67511028 (2700)

NOTE: THIS ASSEMBLY IS STANDARD ONLY ON
CONTINUOUS & DUAL MODE FEEDERS

7A: GROOVED GUM CARRIAGE - 2600 ONLY ASSEMBLY #69211162

<u>DIAGRAM NUMBER</u>	<u>QTY</u>	<u>DESCRIPTION</u>	<u>PART NUMBER</u>
7-1	1	Shaft Front Discharge	44642014
	2	Double Detect Bearing Cup Holder	23560121
	2	Bearing Ball R6	23500095
	2	Clip E 3/8 Waldes	00001150
7-2	1	Shaft Rear Discharge	44642037
	1	Pulley 16T 1/2 Bore w/Flange	43560097
	2	Holder Outboard Bearing Cup	23500032
	2	Bearing Ball R8	23500094
	2	Clip E 1/2 Waldes	00001155
	2	Screw Socket Set 10-32 X 1/8" LG	00003352
	1	Key Woodruff 1/8 X 3/8	00003351
7-3	1	Shaft Drive	44642036
	1	Pulley 20T 1/2 Bore w/Flange Driven	23500097
	1	Pulley 24T 1/2 Bore Flangeless	43560098
	2	Clip E 1/2 Waldes	00001155
	2	Bearing Ball R8	23500094
	3	Screw Socket Set 10-32 X 5/16" LG (1 for flanged pulley, 2 for flangeless pulley)	00002217
	1	Screw Socket Set 10-32 X 1/4" LG (for flanged pulley)	00002216
	2	Key Woodruff 1/8 x 3/8	00003351
7-4	1	Shaft Discharge Feed Roller	43500036
	1	Belt Support Tube	44642016
	2	Bearing Ball R6	23500095
	2	Clip E 3/8 Waldes	00001150
7-5	1	Idler Shaft	43560047
	1	Tube Driven	44642017
	4	Bearing Ball R8	23500094
	2	Clip E 1/2 Waldes	00001155
	2	Ring Grip 1/2 Waldes	00001115
7-6	3	Discharge Belt Clear 1W	44675015
7-7	1	Belt Drive Timing 78XL037	23560078

<u>DIAGRAM NUMBER</u>	<u>QTY</u>	<u>DESCRIPTION</u>	<u>PART NUMBER</u>
7-8	1	Holder Carriage Right Side	44485005
7-9	5	Belt Feed Tan Grooved Composite	23500162
7-10	1	Drive Belt 190XL037	44675021
7-11	1	Holder Carriage Left Side	44485006

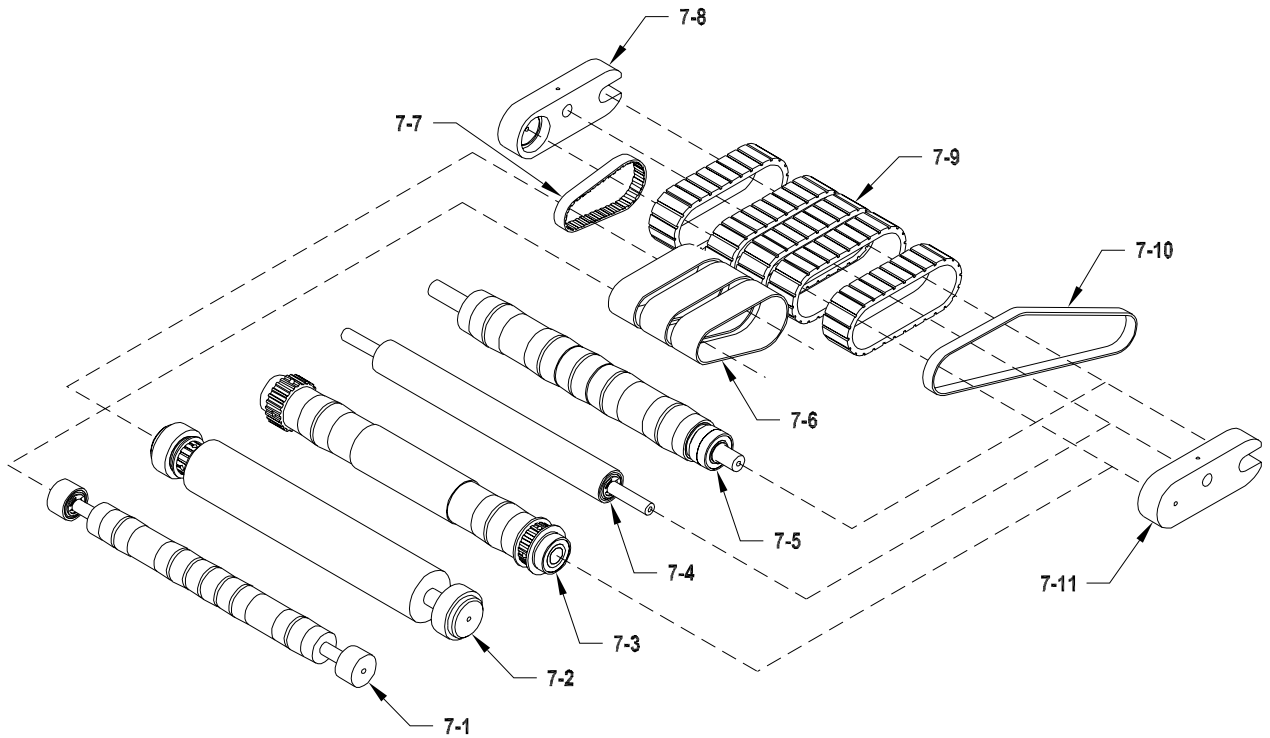

Diagram 7A
2600 Only

Grooved Gum Carriage
Assy #69211162

7B: GROOVED GUM CARRIAGE - 2700 ONLY ASSEMBLY #67511162

<u>DIAGRAM NUMBER</u>	<u>QTY</u>	<u>DESCRIPTION</u>	<u>PART NUMBER</u>
7-1	1	Shaft Front Discharge	51080045
	2	Double Detect Bearing Cup Holder	23560121
	2	Bearing Ball R6	23500095
	2	Clip E 3/8 Waldes	00001150
7-2	1	Shaft Rear Discharge	44675046
	1	Pulley 16T 1/2 Bore w/Flange	43560097
	2	Holder Outboard Bearing Cup	23500032
	2	Bearing Ball R8	23500094
	2	Clip E 1/2 Waldes	00001155
	2	Screw Socket Set 10-32 X 1/8" LG	00003352
	1	Key Woodruff 1/8 X 3/8	00003351
7-3	1	Shaft Drive	44630019
	1	Pulley 20T 1/2 Bore w/Flange Driven	23500097
	1	Pulley 24T 1/2 Bore Flangeless	43560098
	2	Clip E 1/2 Waldes	00001155
	2	Bearing Ball R8	23500094
	3	Screw Socket Set 10-32 X 5/16" LG (1 for flanged pulley, 2 for flangeless pulley)	00002217
	1	Screw Socket Set 10-32 X 1/4" LG (for flanged pulley)	00002216
	2	Key Woodruff 1/8 x 3/8	00003351
7-4	1	Shaft Discharge Feed Roller	43550036
	1	Belt Support Tube	44630003
	2	Bearing Ball R6	23500095
	2	Clip E 3/8 Waldes	00001150
7-5	1	Idler Shaft	43555047
	1	Tube Driven	44630004
	4	Bearing Ball R8	23500094
	3	Clip E 1/2 Waldes	00001155
7-6	3	Discharge Belt Clear 1W	44675015
7-7	1	Belt Drive Timing 78XL037	23560078
7-8	1	Holder Carriage Right Side	44485005

<u>DIAGRAM NUMBER</u>	<u>QTY</u>	<u>DESCRIPTION</u>	<u>PART NUMBER</u>
7-9	7	Belt Feed Tan Grooved Composite	23500162
7-10	1	Drive Belt 190XL037	44675021
7-11	1	Holder Carriage Left Side	44485006

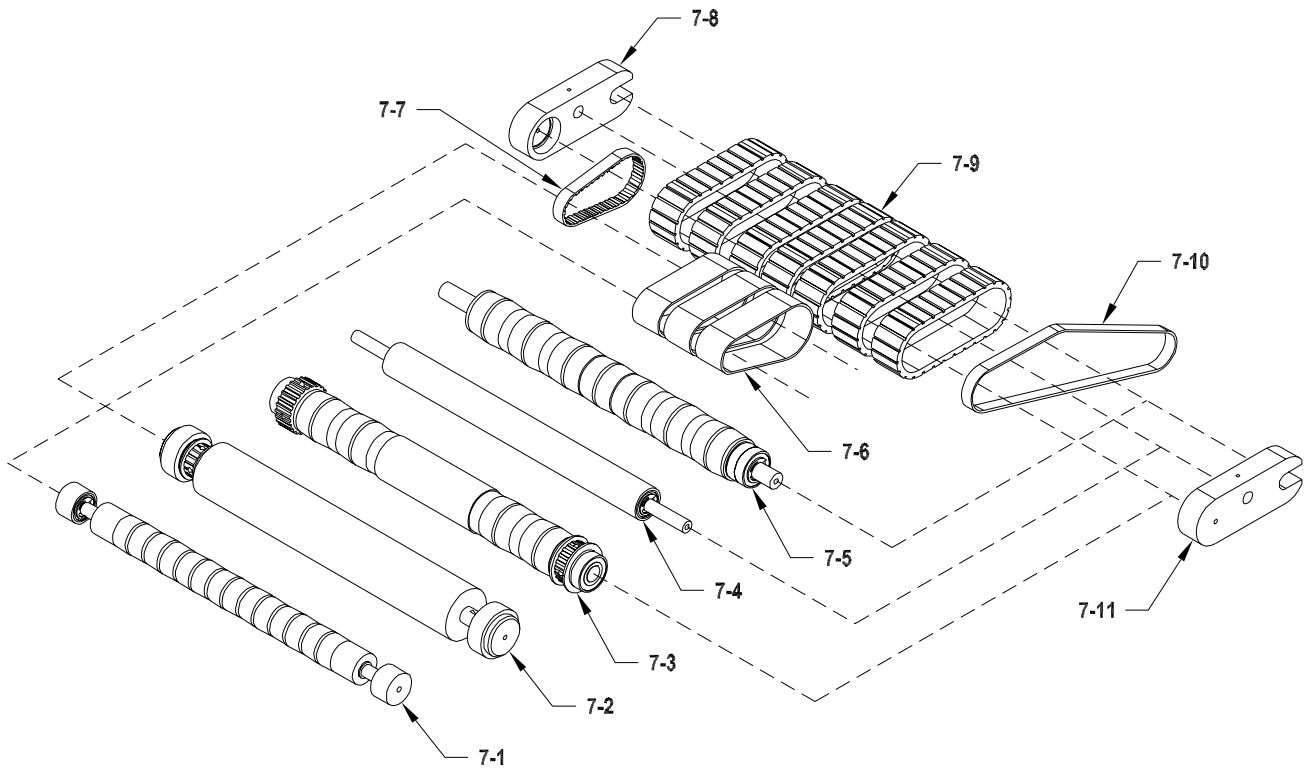

Diagram 7B
2700 Only
 Grooved Gum Carriage
 Assy #67511162

8: HOLD DOWN ASSEMBLY #69211023 (2600) OR #67511023 (2700)

<u>DIAGRAM NUMBER</u>	<u>QTY</u>	<u>DESCRIPTION</u>	<u>P/N 2600</u>	<u>P/N 2700</u>
8-1	2	Clip E 3/8 Waldes	00001150	00001150
8-2	1	Shaft Hold Down	44642029	44675026
8-3	2	Cap Protective	44675025	44675025
8-4	2	SHCS 10-32 X 5/8" LG	00002320	00002320
	2	Spacer .25 X .375 Tapped 10-32	44633027	44633027
	2	Knob Wing #10 w/o Screw	23500076	23500076
8-5	1	BHCS 10-32 x 3/16" LG	00003339	00003339
8-6	1	Block Hold Down	44675023	44675023
8-7	9	Ball 5/8 Chrome Steel	44500033	44500033
8-8	3	Cover Hold Down	44675024	44675024
8-9	6	BHCS 8-32 X 1/4" LG	00002210	00002210

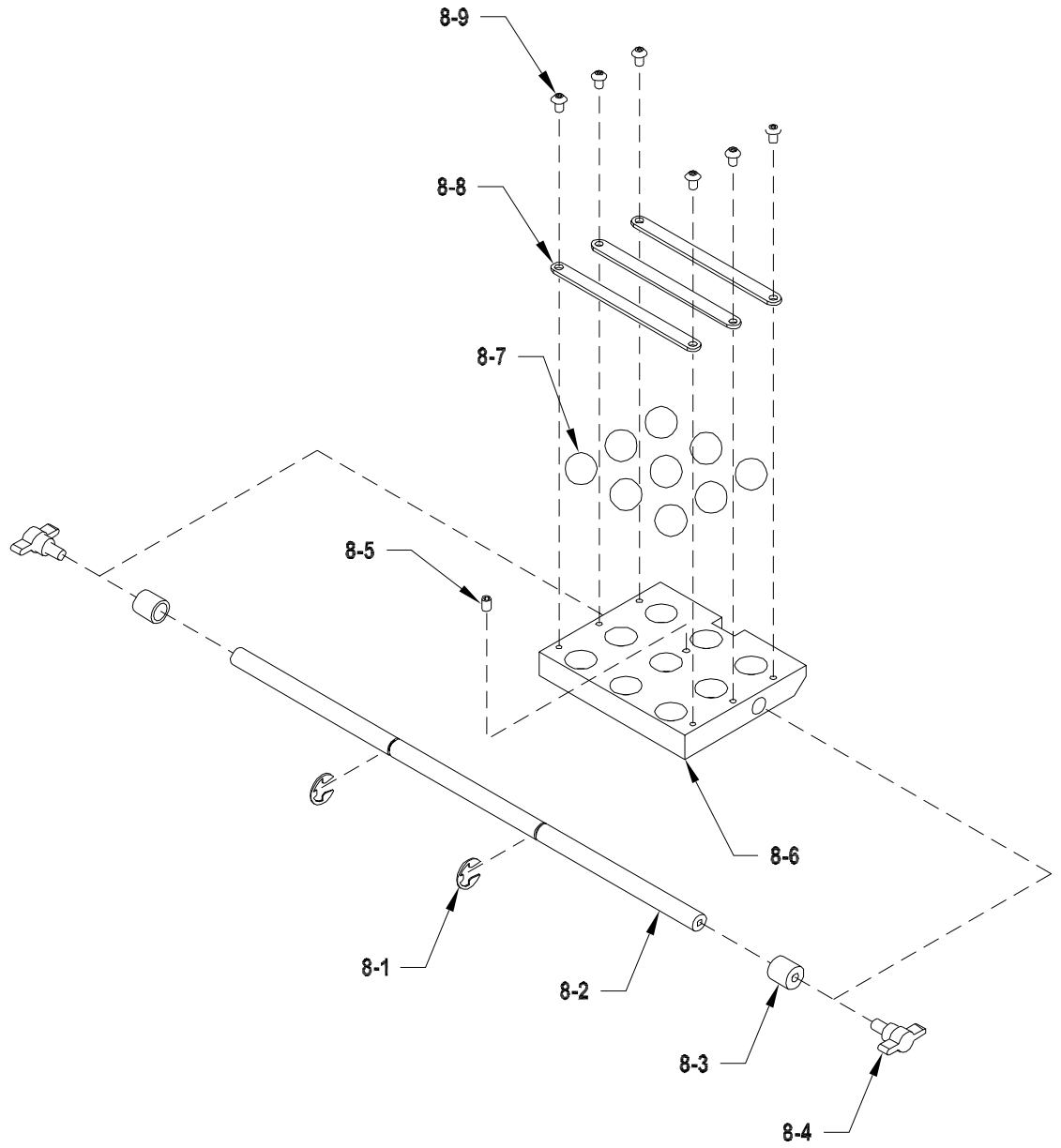

Diagram 8
 Hold Down
 Assy #69211023 (2600)
 Assy #67511023 (2700)

9: ELECTRICAL COMPONENTS

ASSEMBLY #69211002 (2600) OR #67511002 (2700)

<u>DIAGRAM NUMBER</u>	<u>QTY</u>	<u>DESCRIPTION</u>	<u>PART NUMBER</u>
9-1	1	Base Plate	44692002 (2600) 44630002 (2700)
9-2	1	Board Stepper Drive BLD72-5	44649030
9-3	1	Grommet Rubber	44649054
9-4	1	Board Power DC 5V & 12V 2.5 X 4.25	44649033
9-5	1	Bracket Power Supply Mounting	44649036
9-6	1	Motor Drive Stepper Assembly	53511390
9-7	1	Motor Mount	44630011
9-8	1	Pulley 18T 1/2 Bore W/Flange & Hub	44350053
	2	Screw Socket Set 10-32 X 1/8" LG	00003352
9-9	4	Foot Recessed 5/8 Cylindrical	44642042
9-10	1	Nut Hex 6-32 Zinc	00002113
9-11	1	Fan Assembly ST/Reliant Cooling	64911035
9-12	1	Transformer Power 300VA	44683025
9-13	1	Bracket Mounting CPU Board	44649038
9-14	1	Board I/O Expansion	44675035
9-15	4	Standoff Male/Female 6-32 X 1	44649048
9-16	1	Board ES CPU	44675037
NS	16	Cable Tie Wrap	435SO263
NS	2	Terminal Female	44649046
NS	34	Sheathing #0 HP Black	44649085
NS	1	Cable Ribbon 2 Inch 50 Pin	44675036
NS	4	Terminal Disconnect Female 22-18 ga	53500045
NS	4	Joint Wire Crimp Style	53500152
NS	2	Terminal Disc Female .020 22-18 AWG	53500254
NS	1	Cable DC Power Supply Assy AC Input	63011006
NS	1	Cable Ground Wire Assembly	63011007
NS	1	Harness Safety Interlock	64911001
NS	1	Harness Sheet Sensor	64911002
NS	1	Harness DC Power Supply	64911003
NS	1	Harness Drive Control	64911007
*NS	2	Holder Adhesive Wire	23500079
*NS	3	Cable Tie Wrap	435SO263
*NS	1	Power Cord (115V Models Only)	53511020
*NS	1	Power Cord / Allen Wrench Set (230V Only)	53522210
*NS	1	(DM) Dual Mode (EPROM)	63511003
*NS	1	(CM) Continuous Mode (EPROM)	63511004
*NS	1	(PM) Presentation Mode (EPROM)	63511005

(CM), (DM), (PM): Indicate feature availability specific to continuous, dual, and/or presentation mode feeders.

*Part is not included with assembly #67511002 or #69211002 and must be ordered separately.

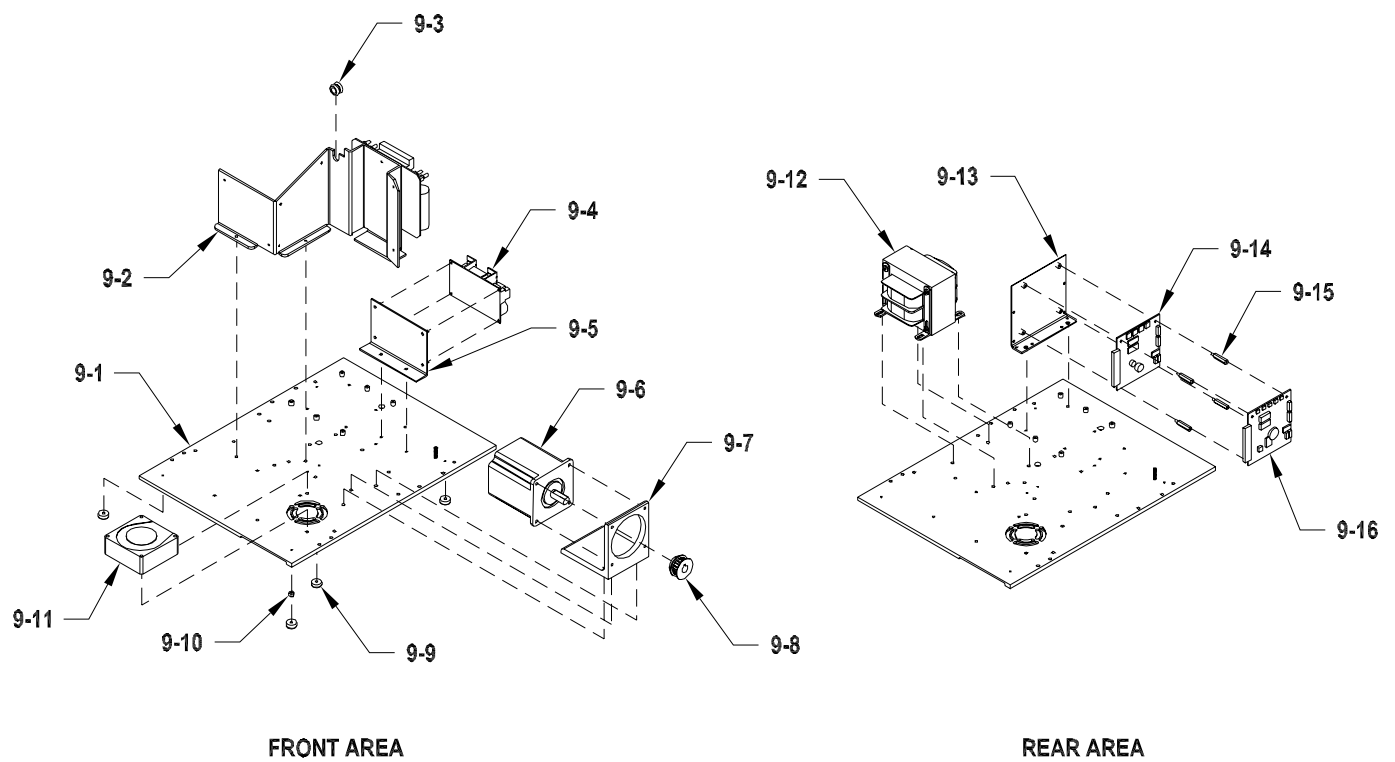

Diagram 9
 Electrical Components
 Assy #69211002 (2600)
 Assy #67511002 (2700)

10: BASE FEATURES 1

<u>DIAGRAM NUMBER</u>	<u>QTY</u>	<u>DESCRIPTION</u>	<u>PART NUMBER</u>
10-1	2	Mount Front Base Plate	44675003
10-2	2	Mount Back Base Plate	44675004
10-3	2 (DM,PM)	T Handle Screw Assembly	43511022
10-4	1	Cover Bottom Protective	44692008 (2600) 44675022 (2700)
10-5	1	Bracket Rubber Spacer	44640009
10-6	1	Support O Ring Cover	43555068
10-7	1 (DM,PM)	Sensor ST Sheet Assembly	64911011
10-8	1	Switch Safety Interlock Assembly	64911009
10-9	2	Shaft Top Cover Hinge Mount	44640011
10-10	2	Hinge Top Cover Mount	44640012
10-11	1	Side Guide Right 2624	44640003
	1	Label Warning	44600005
10-12	1	Side Guide Left 2624	44640002
	1	Label Warning	44600005
10-13	1	Shell Reliant	44692001 (2600) 44675001 (2700)
10-14	1	Plug 2 Hole Cover	44500061
	1	Label, Belt Routing	44500071
10-15	1	Label Warning (For Protective Cover)	44600004
NS	1	Belt Tensioner Assembly	23511290
NS	2	Guard Accordion Rear	44600001
NS	1 (DM, PM)	Holder Adhesive Wire	23500079

(CM), (DM), (PM): Indicate feature availability specific to continuous, dual, and/or presentation mode feeders.

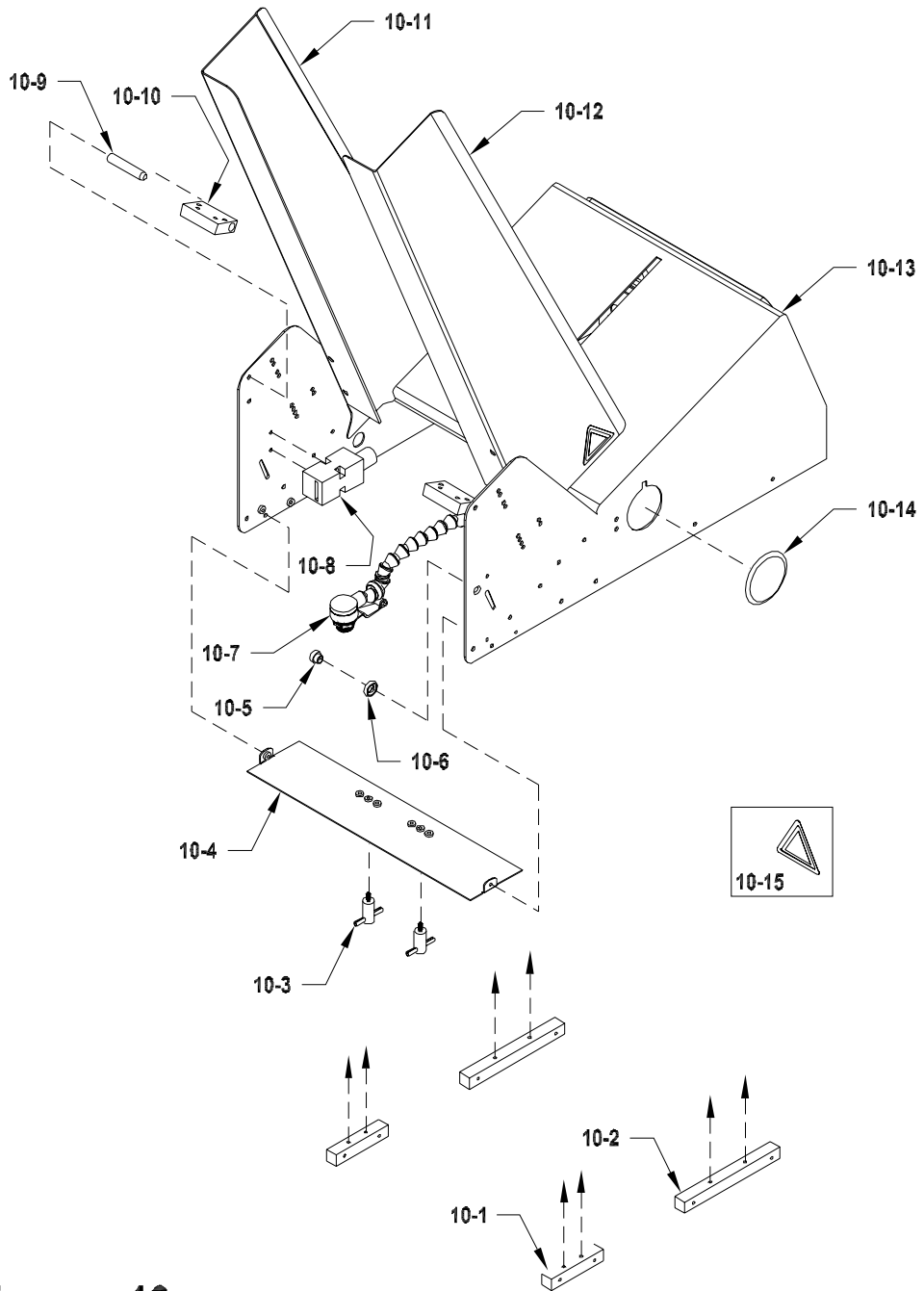

Diagram 10
Base Features 1

11: BASE FEATURES 2

<u>DIAGRAM NUMBER</u>	<u>QTY</u>	<u>DESCRIPTION</u>	<u>P/N 2600</u>	<u>P/N 2700</u>
11-1	1	Module AC Power Entry (w/o fuse)	44649034	44649034
	2	Fuse 3A 250V Slo-Blo GMD 5 X 20mm	53500006	53500006
11-2 (DM)	1	Select Switch Harness Assembly	67511026	67511026
11-3	1	Harness Fault/Reset Switch Assembly	67511034	67511034
11-4 (CM,PM)	1	Graphic Standard Lower	44692006	44675016
(DM)	1	Graphic Mode Select	44692005	44675027
11-5	1	Cover Plate	44699016	44699016
11-6	1	Graphic Standard Upper	44692004	44675017
11-7	1	Harness Potentiometer Assembly	67511030	67511030

(CM), (DM), (PM): Indicate feature availability specific to continuous, dual, and/or presentation mode feeders.

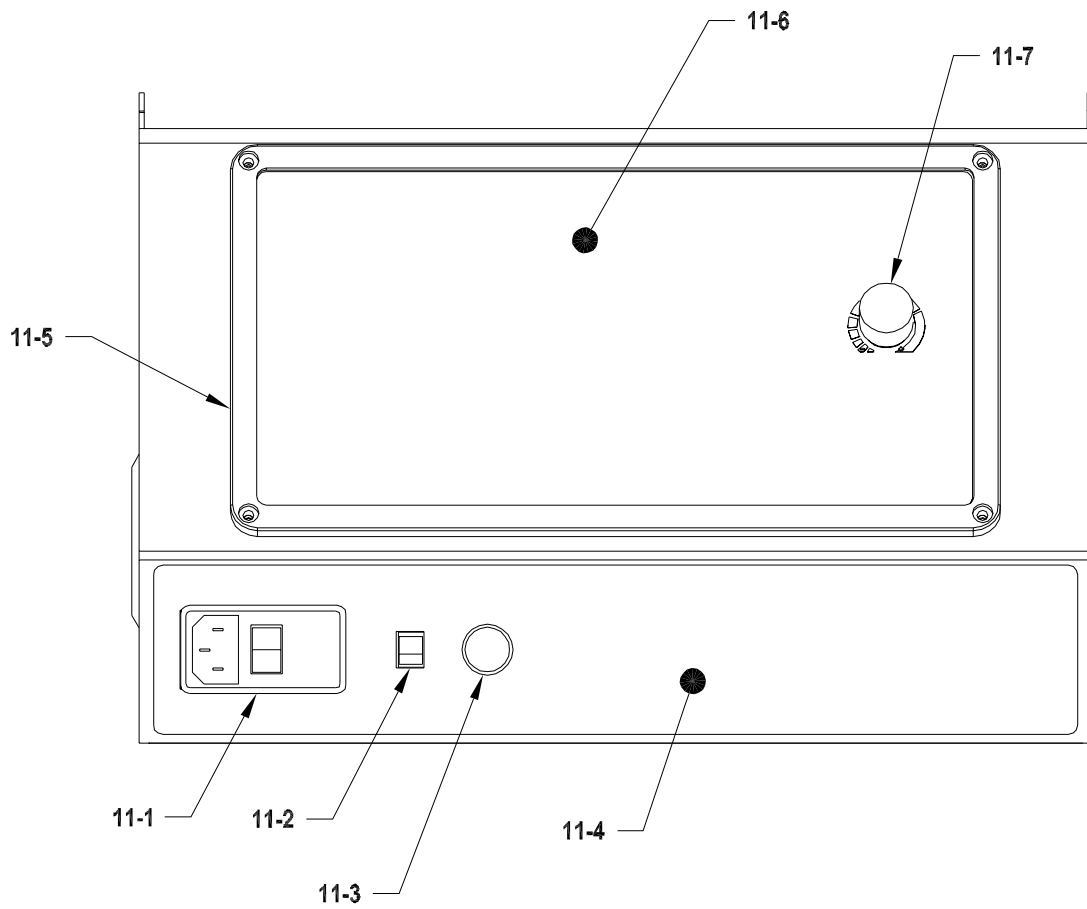

Diagram 11
Base Features 2

12: SUPPORT STAND ASSEMBLY #43511200

NOTE: THIS ASSEMBLY STANDARD ONLY ON PRESENTATION & DUAL MODE FEEDERS

<u>DIAGRAM NUMBER</u>	<u>QTY</u>	<u>DESCRIPTION</u>	<u>PART NUMBER</u>
12-1	2	Foot Leveling	43500201
12-2	1	Support Stand	43500200
12-3	2	Knob Large Black	23500093
	2	SHCS 1/4-20 X 1/2" LG	00002360
12-4	4	SHCS 10-32 X 1/2" LG	00002315
	4	Washer Flat #10	00002607

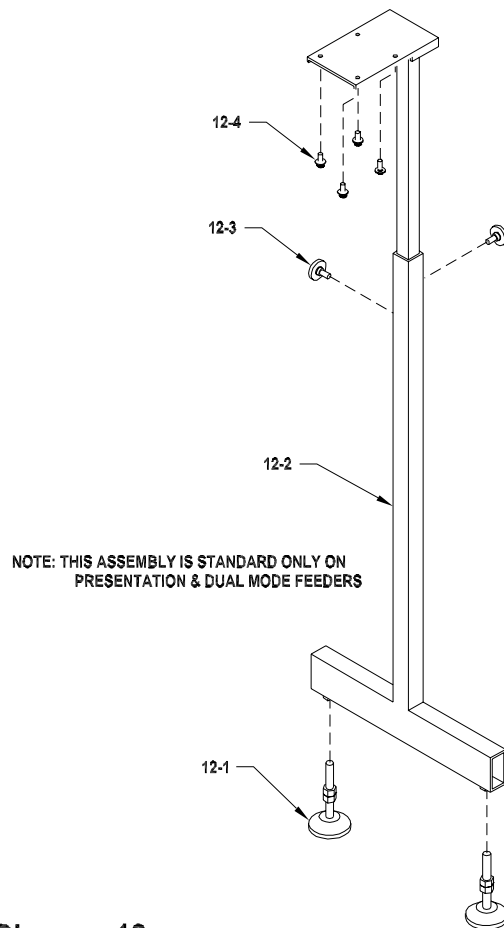

Diagram 12
Support Stand
Assy #43511200

13: STANDARD MATERIAL HOLD DOWN (QTY 2) ASSEMBLY #23511008

NOTE: THIS ASSEMBLY STANDARD ONLY ON PRESENTATION & DUAL MODE FEEDERS

<u>DIAGRAM NUMBER</u>	<u>QTY</u>	<u>DESCRIPTION</u>	<u>PART NUMBER</u>
13-1	1	Knob Wing #10 w/o Screw	23500076
13-2	1	SHCS 10-32 X 1/2" LG	00002315
13-3	1	Bracket Universal Guide Bar	23500051
13-4	1	Bar Universal Guide	23500050
13-5	1	Washer Flat #10	00002607
13-6	1	SHCS 10-32 X 3/8" LG	00002310
13-7	1	Spring Material Hold Down	23500102
13-8	1	BHCS 8-32 X 1/4" LG	00002210

NOTE: THIS ASSEMBLY IS STANDARD ONLY ON
DUAL AND PRESENTATION MODE FEEDERS

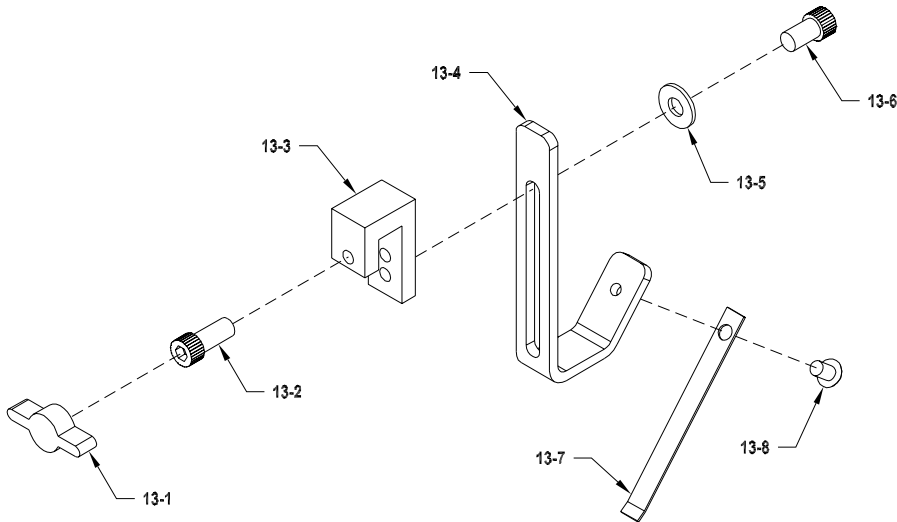
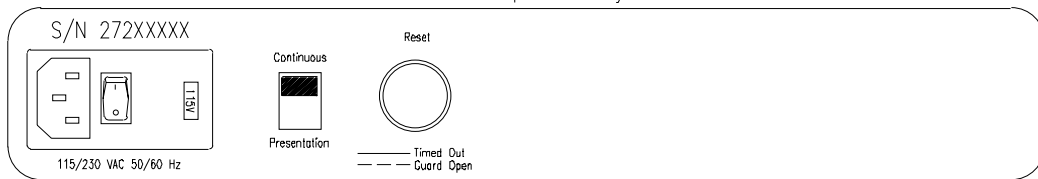
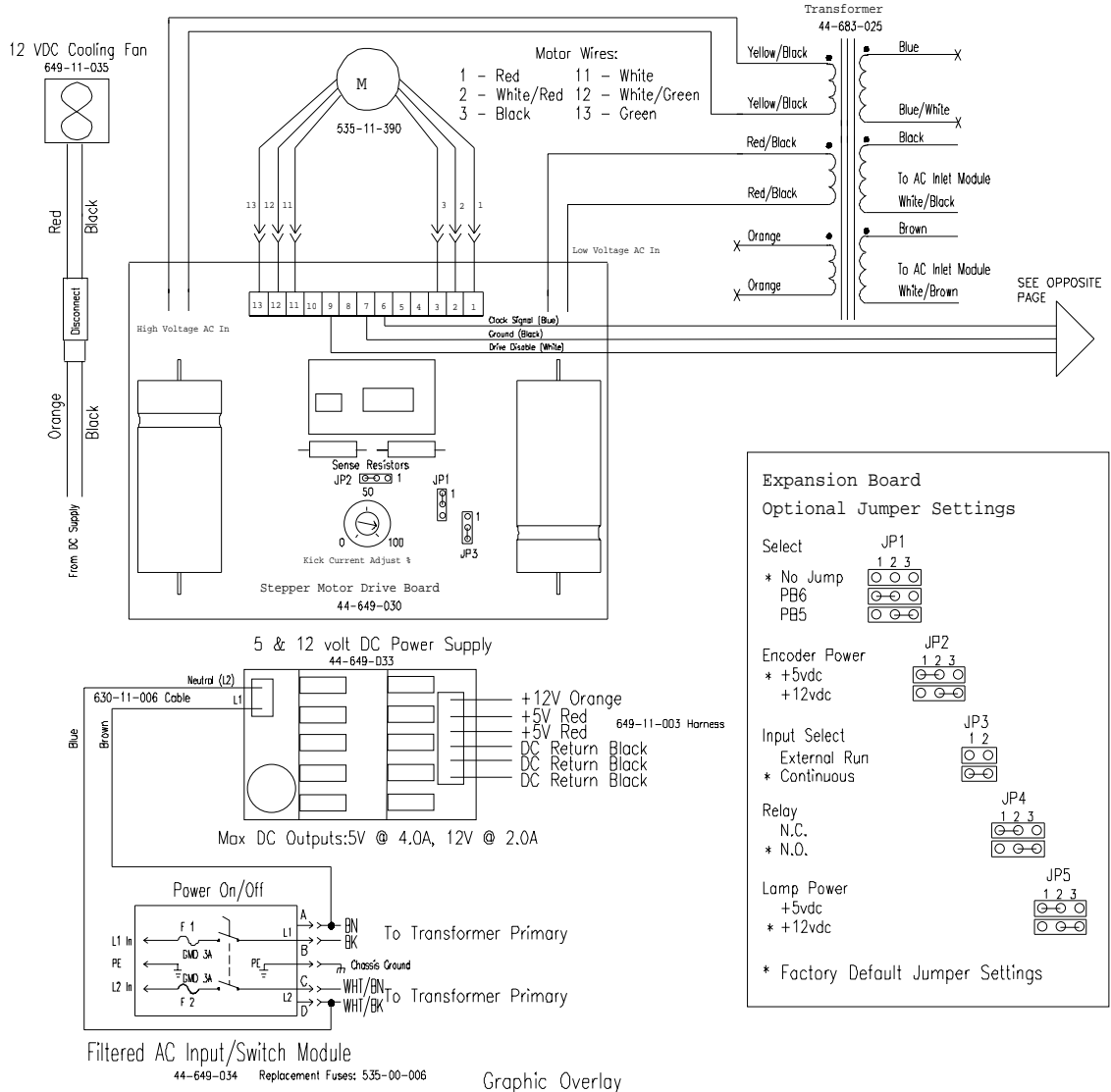

Diagram 13

Std Material Hold Down
Assy #23511008

Reliant 2600/2700 Dual Mode w/o External Run Option



9 Electrical Components

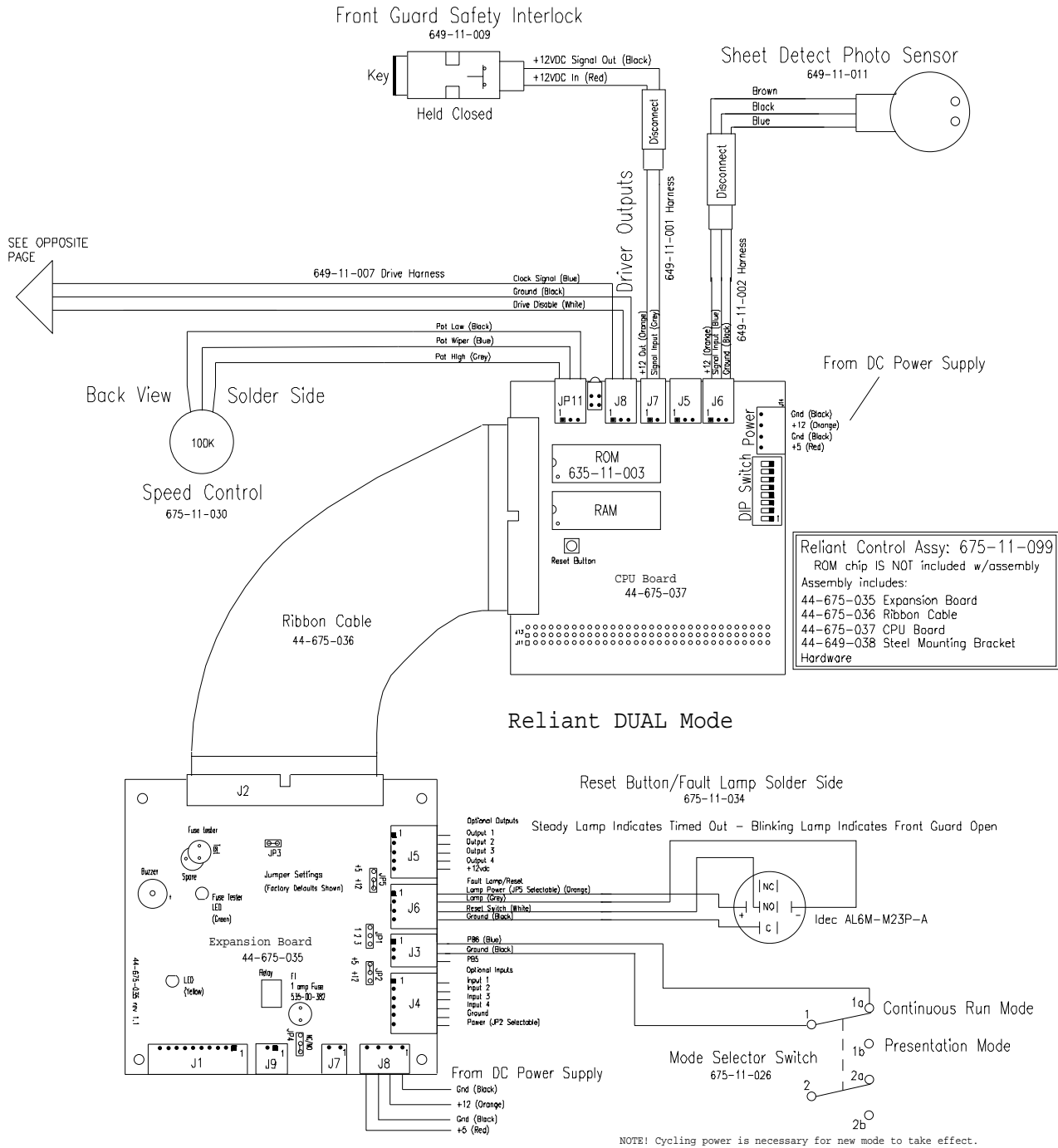

Reliant Continuous Mode w/External Run Dry Contact

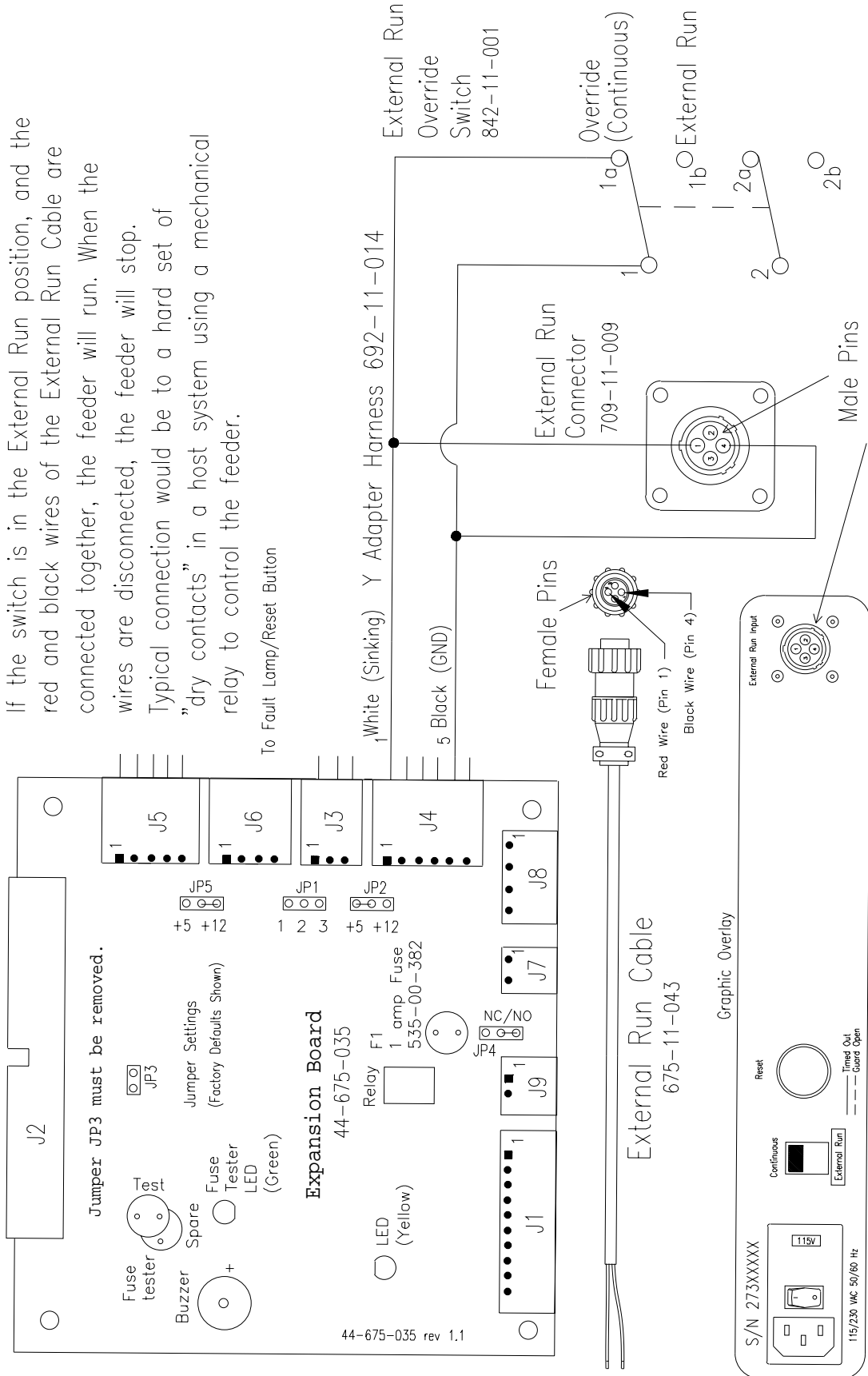

If the switch is in the External Run position, and the red and black wires of the External Run Cable are connected together, the feeder will run. When the wires are disconnected, the feeder will stop. Typical connection would be to a hard set of "dry contacts" in a host system using a mechanical relay to control the feeder.

To Fault Lamp/Reset Button

1 White (Sinking) Y Adapter Harness 692-11-014

5 Black (GND)

External Run
Override
Switch
842-11-001

External Run
Connector
709-11-009

Female Pins

External Run Cable
675-11-043

Red Wire (Pin 1)
Black Wire (Pin 4)

1a
1b
2a
2b

External Run

Male Pins

Graphic Overlay

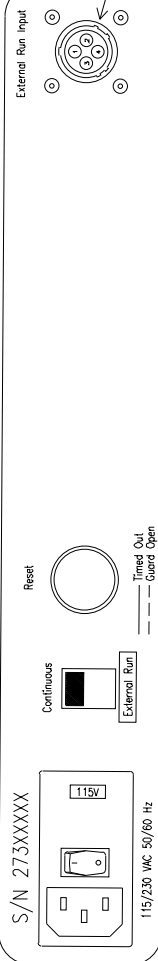

44-675-035 rev 1.1

Reliant Dual Mode w/External Run 3-28VDC

Note! External Run does not operate in Presentation Mode.

If the switch is in the External/Continuous Run position, and the red and black wires of the External Run Cable are connected to a voltage of 3 to 28VDC, the feeder will run.

When the voltage is removed, the feeder will stop. Typical connection would be to a host system that supplies a voltage when the feeder is to be run, and removes the voltage when the feeder is to stop.

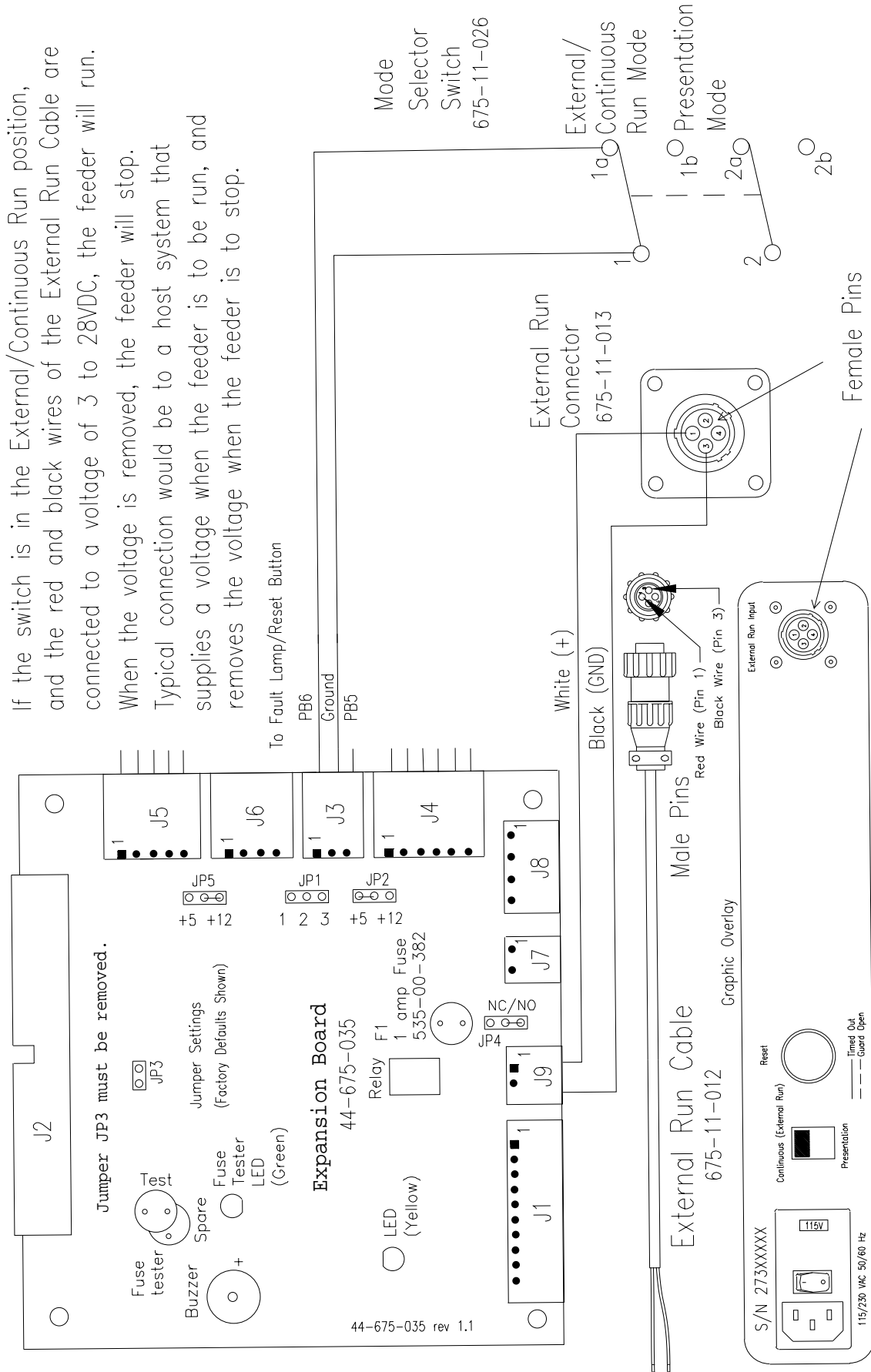

Reliant Dual Mode w/Powered External Run

Note! External Run does not operate in Presentation Mode.

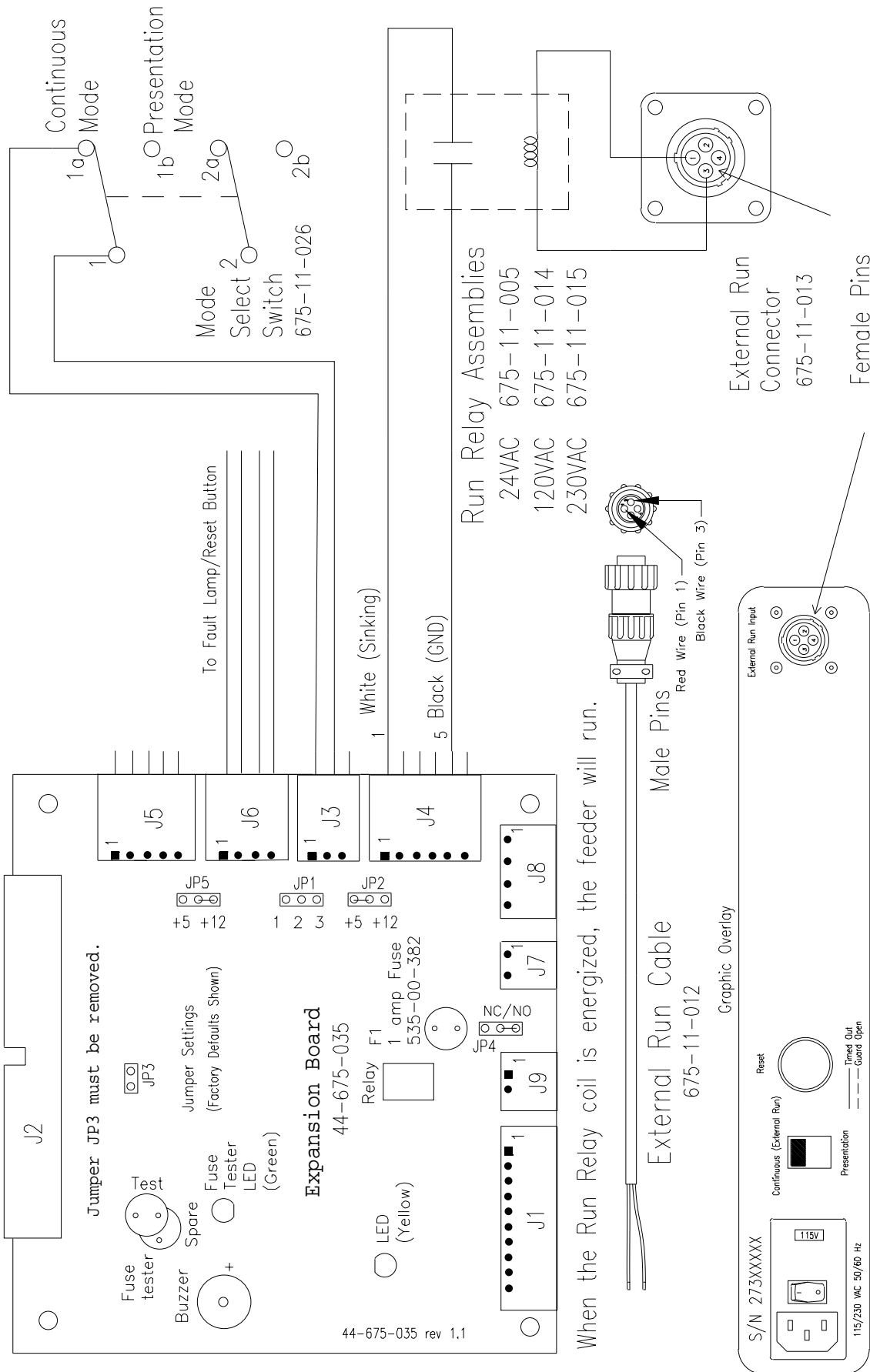

44-675-035 rev 1.1

Reliant 2600/2700 Continuous Mode w/o External Run Option

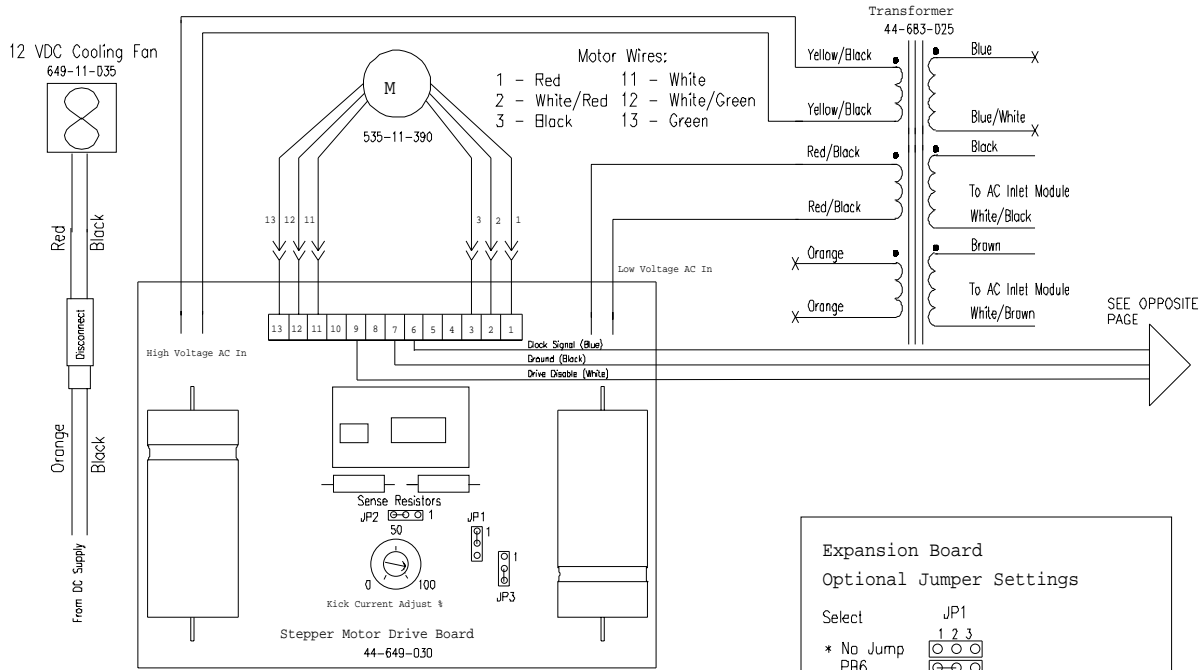

SEE OPPOSITE PAGE

5 & 12 volt DC Power Supply

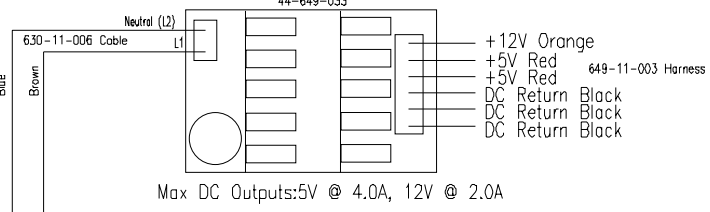

Expansion Board
 Optional Jumper Settings

Select JP1
 * No Jump
 PB6
 PB5

Encoder Power JP2
 * +5vdc
 +12vdc

Input Select JP3
 External Run
 * Continuous

Relay JP4
 N.C.
 * N.O.

Lamp Power JP5
 +5vdc
 * +12vdc

* Factory Default Jumper Settings

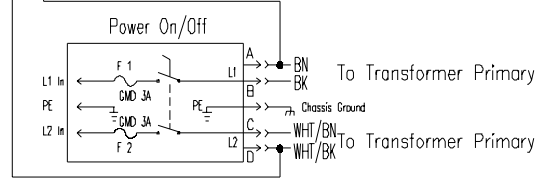

Filtered AC Input/Switch Module

44-649-034 Replacement Fuses: 535-00-006

Graphic Overlay

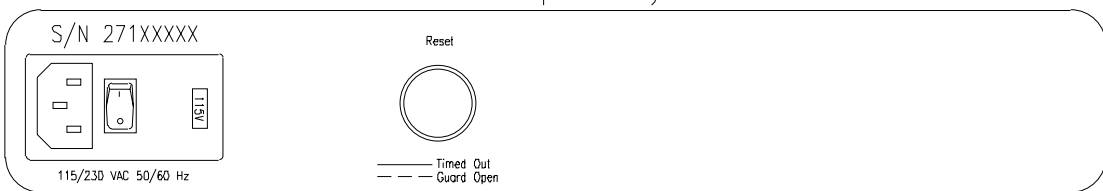

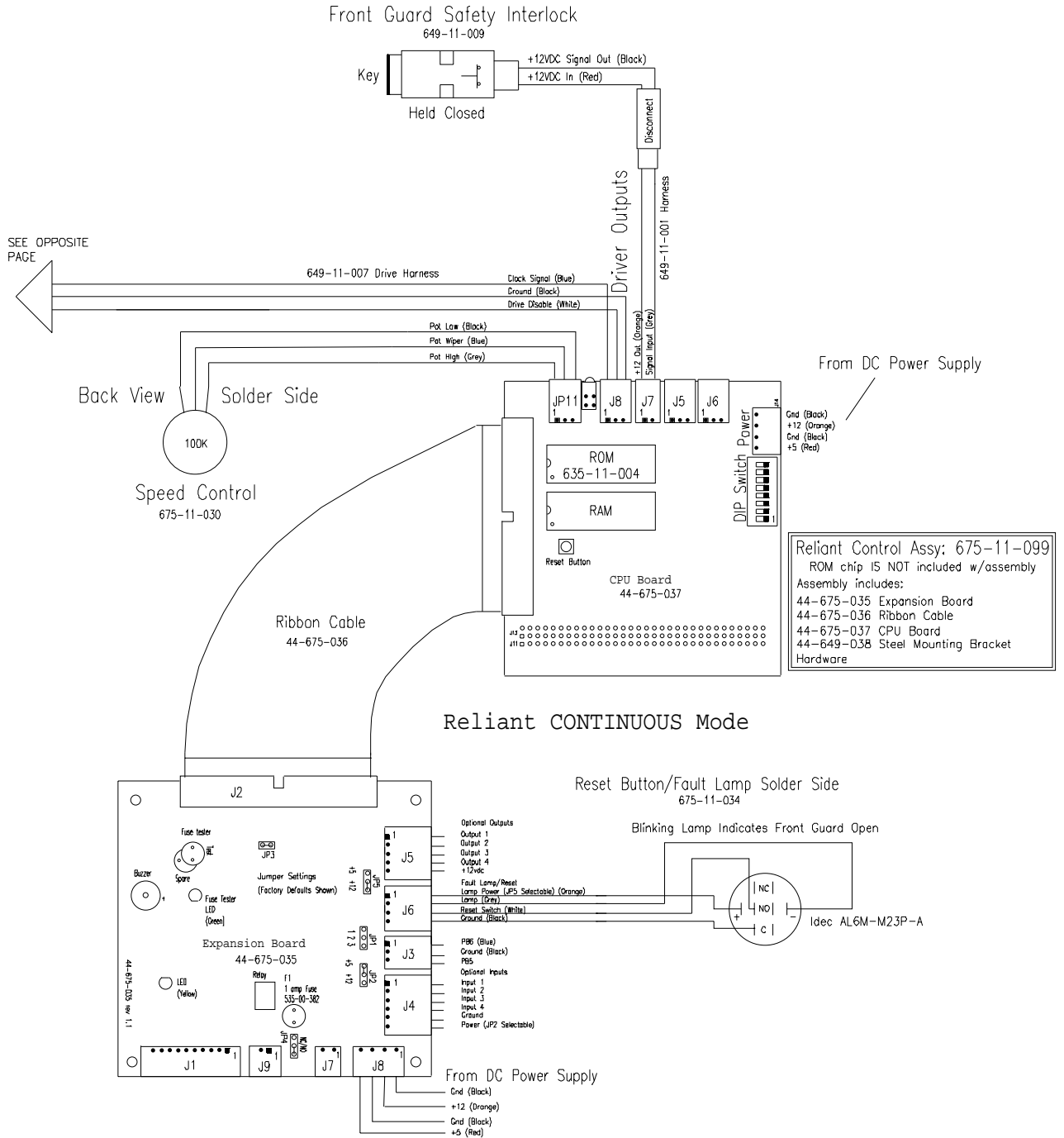

Reliant Continuous Mode w/External Run Dry Contact

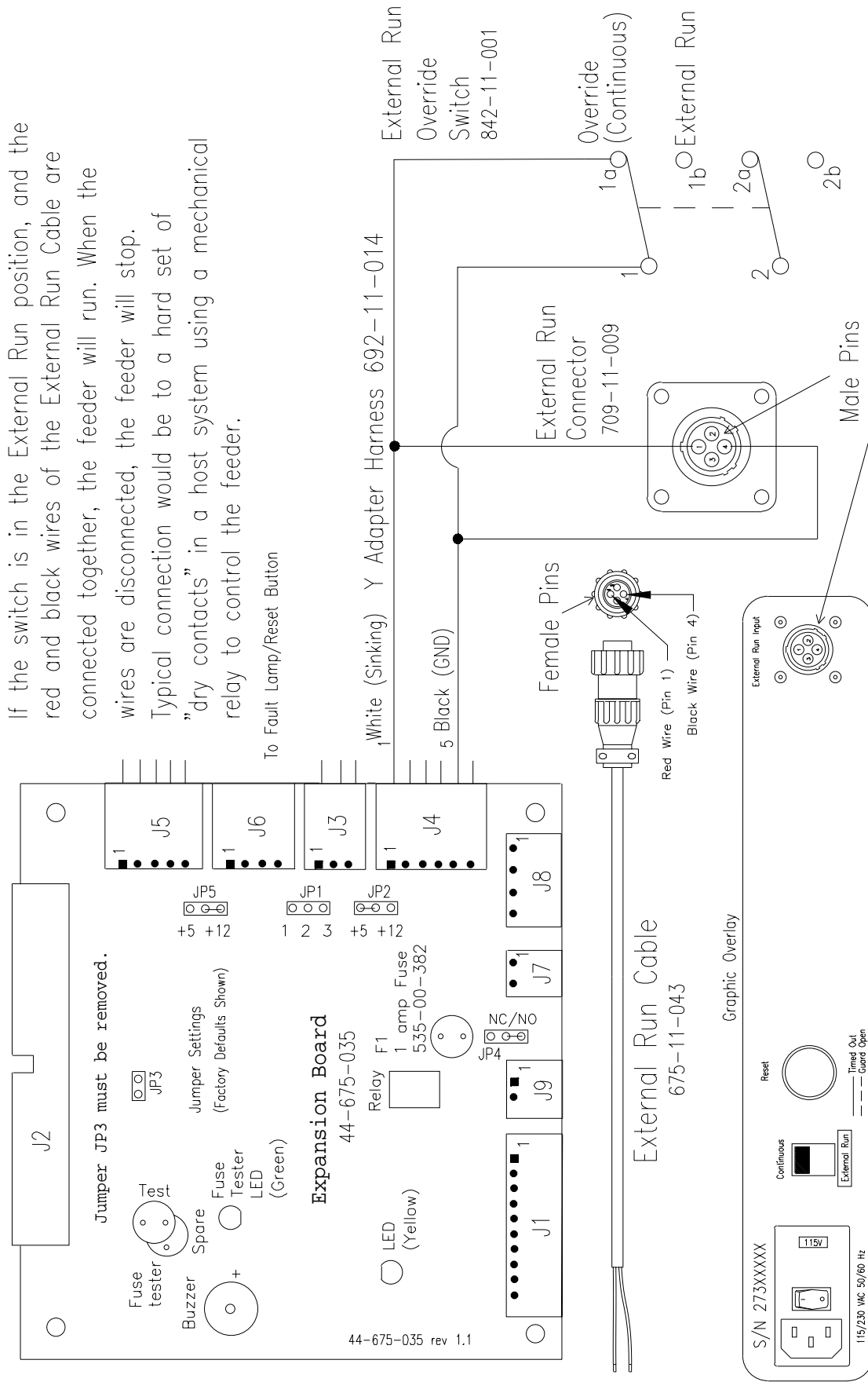

Reliant Continuous Mode w/Powered External Run

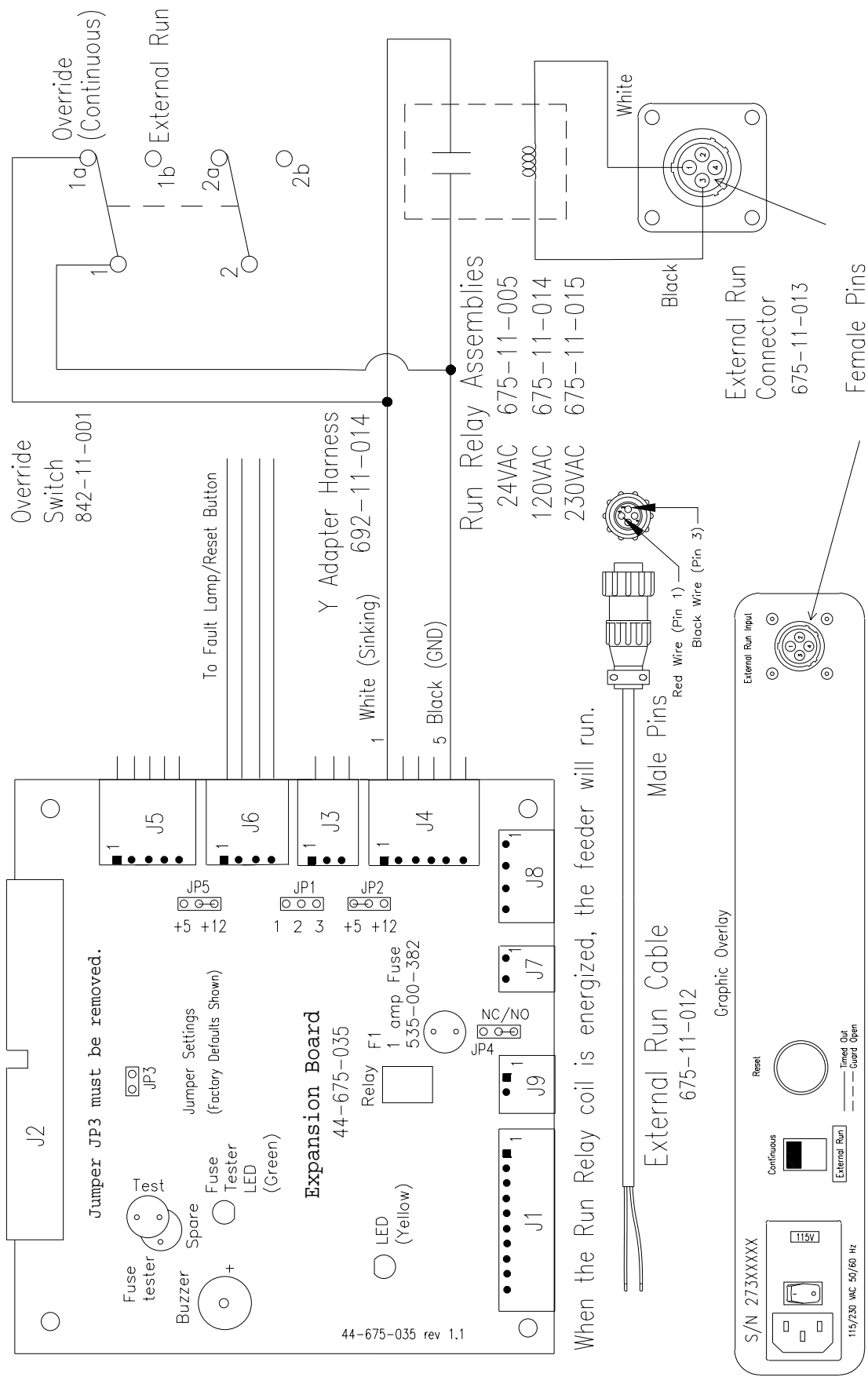

When the Run Relay coil is energized, the feeder will run.

Reliant 2600/2700 Presentation Mode Electrical Wiring

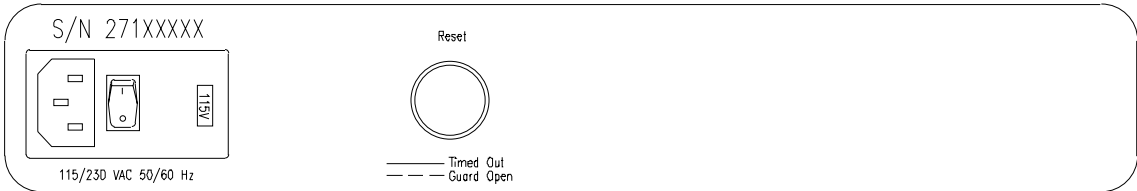
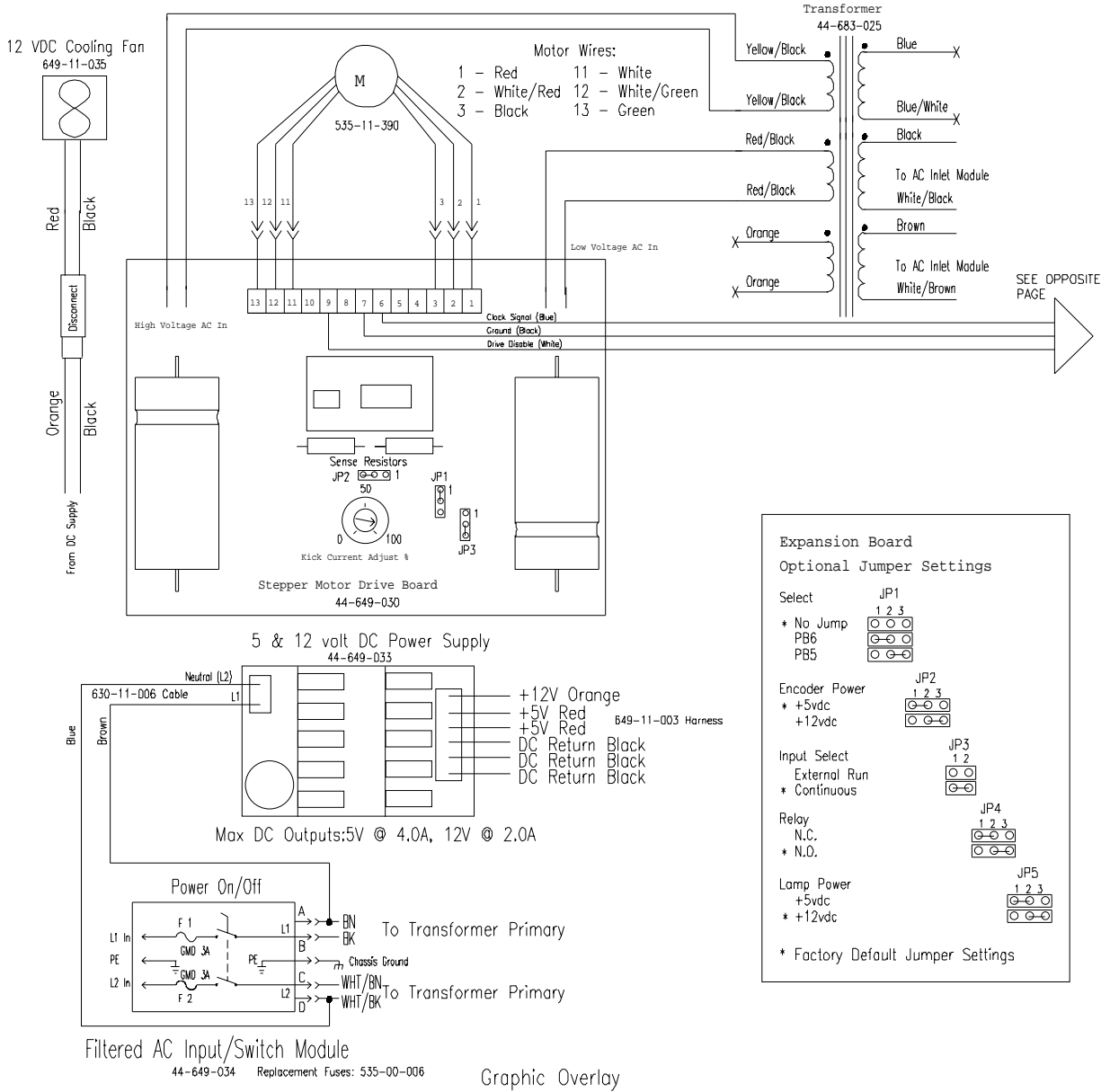

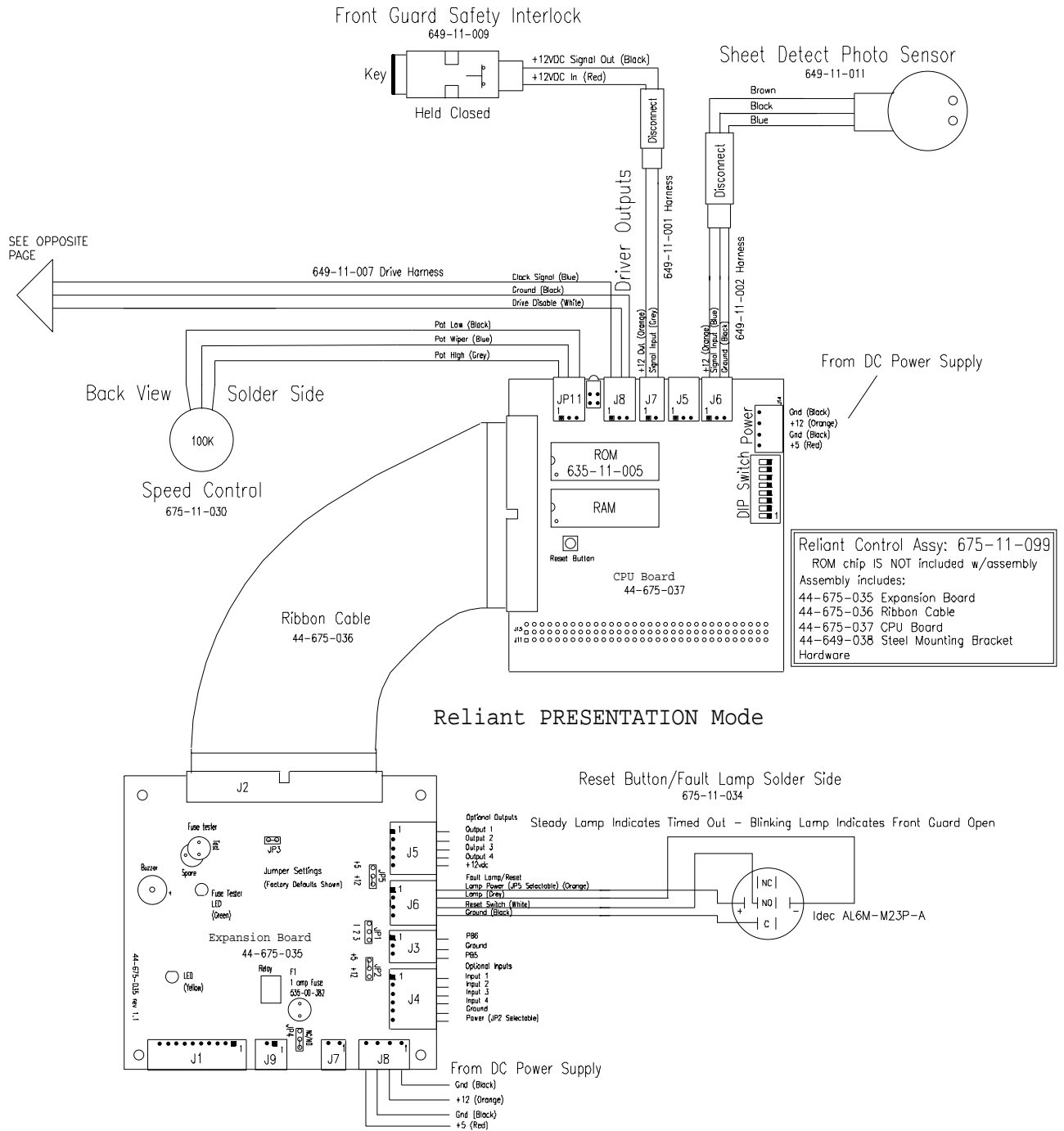

Reliant 2600/2700 Emergency Stop Option

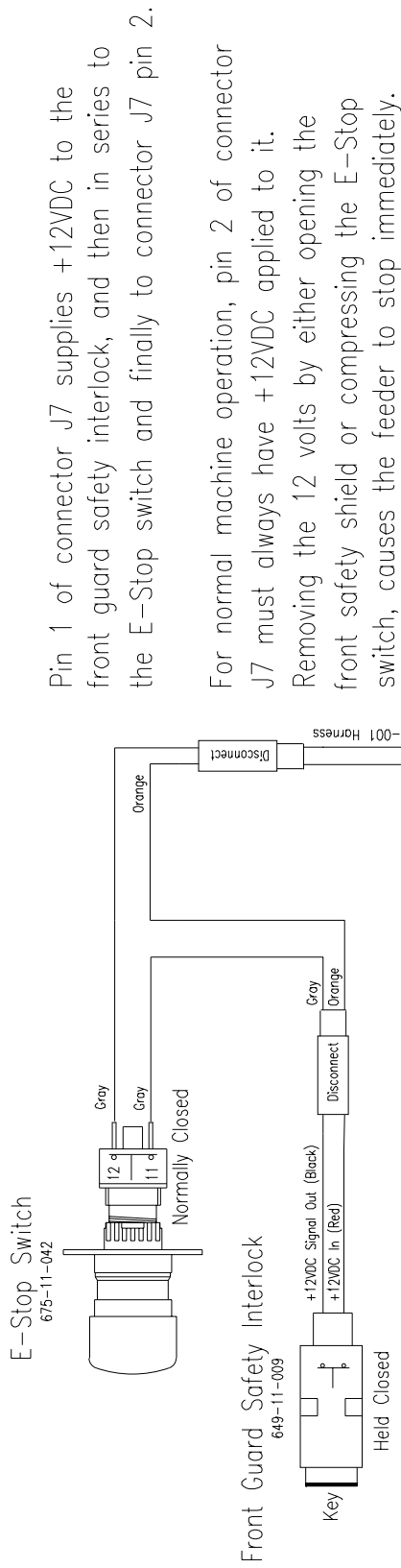

Pin 1 of connector J7 supplies +12VDC to the front guard safety interlock, and then in series to the E-Stop switch and finally to connector J7 pin 2.

For normal machine operation, pin 2 of connector J7 must always have +12VDC applied to it.

Removing the 12 volts by either opening the front safety shield or compressing the E-Stop switch, causes the feeder to stop immediately.

Reliant 2600/2700 Bryce

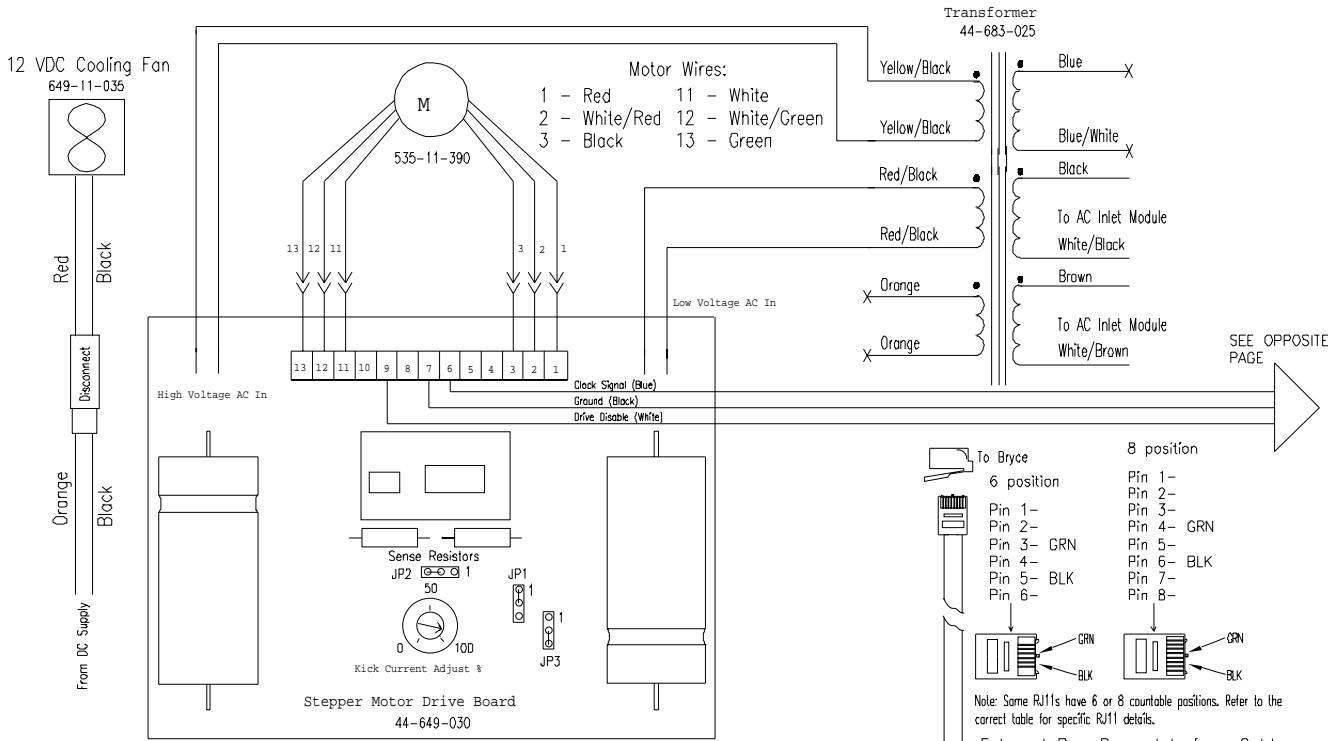

SEE OPPOSITE PAGE

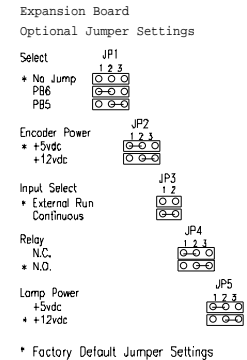
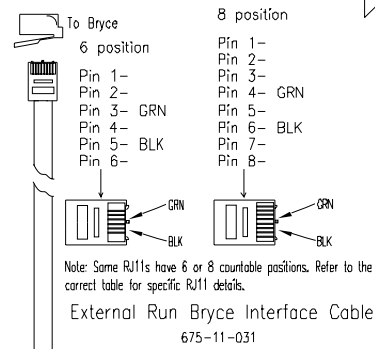
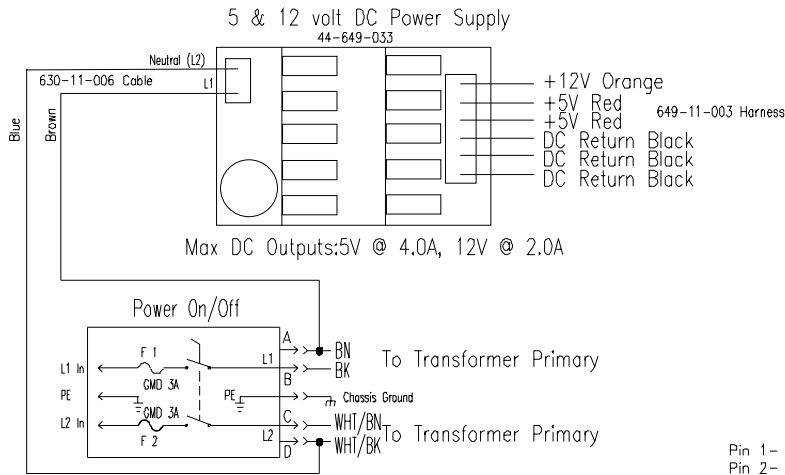

Pin 1- GRN
 Pin 2-
 Pin 3- BLK
 Pin 4-

Graphic Overlay

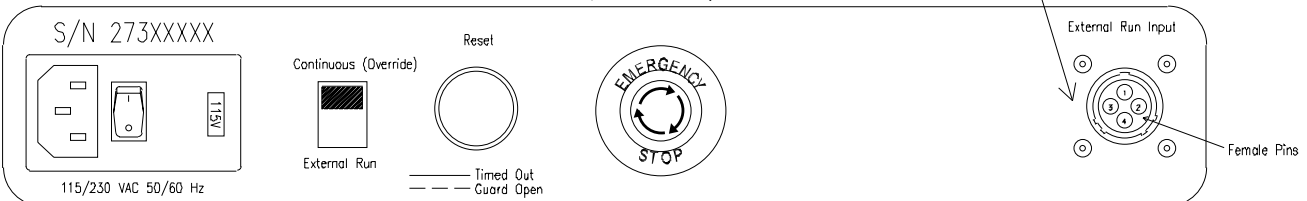

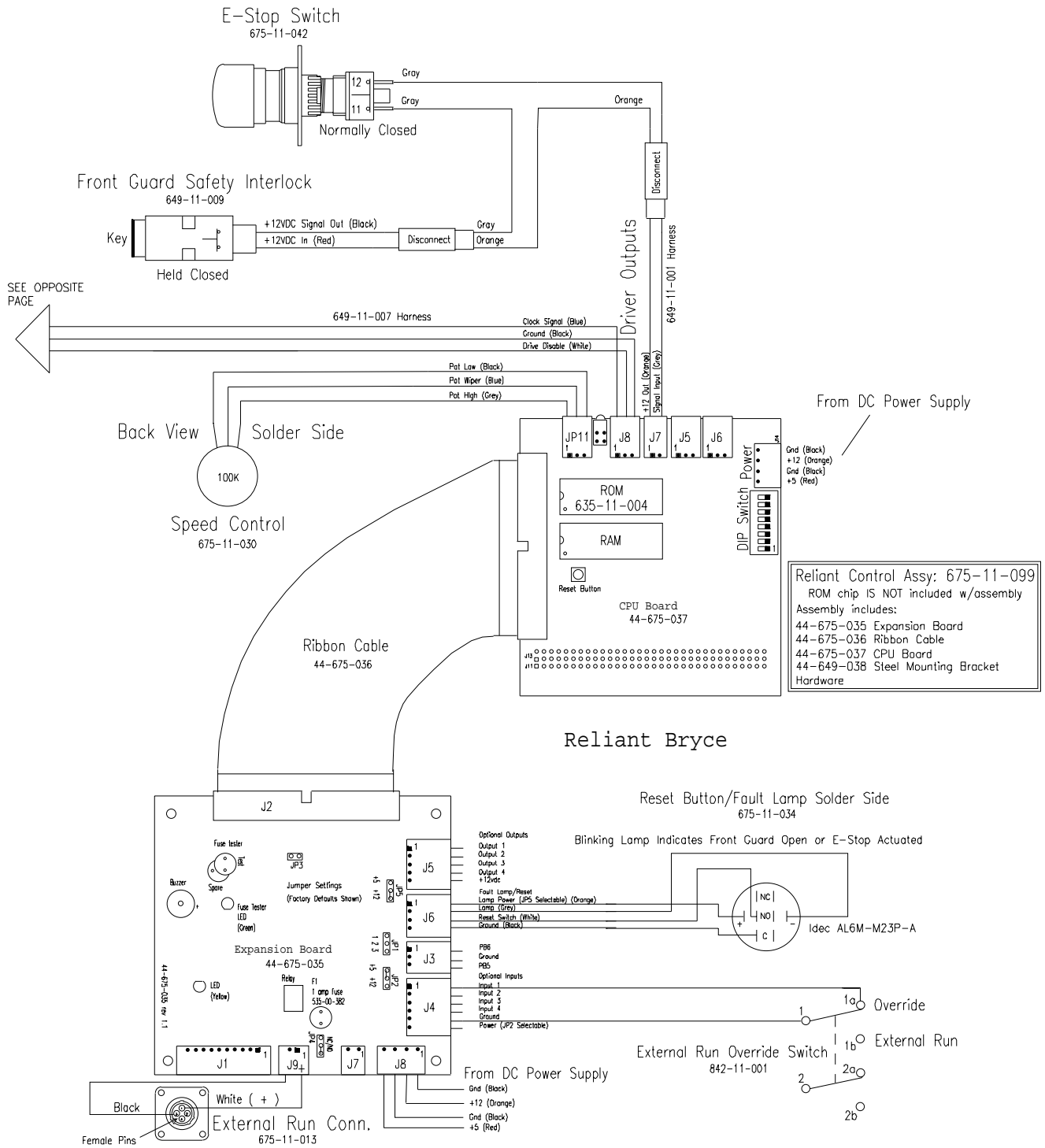

Reliant 2600/2700 Datatech

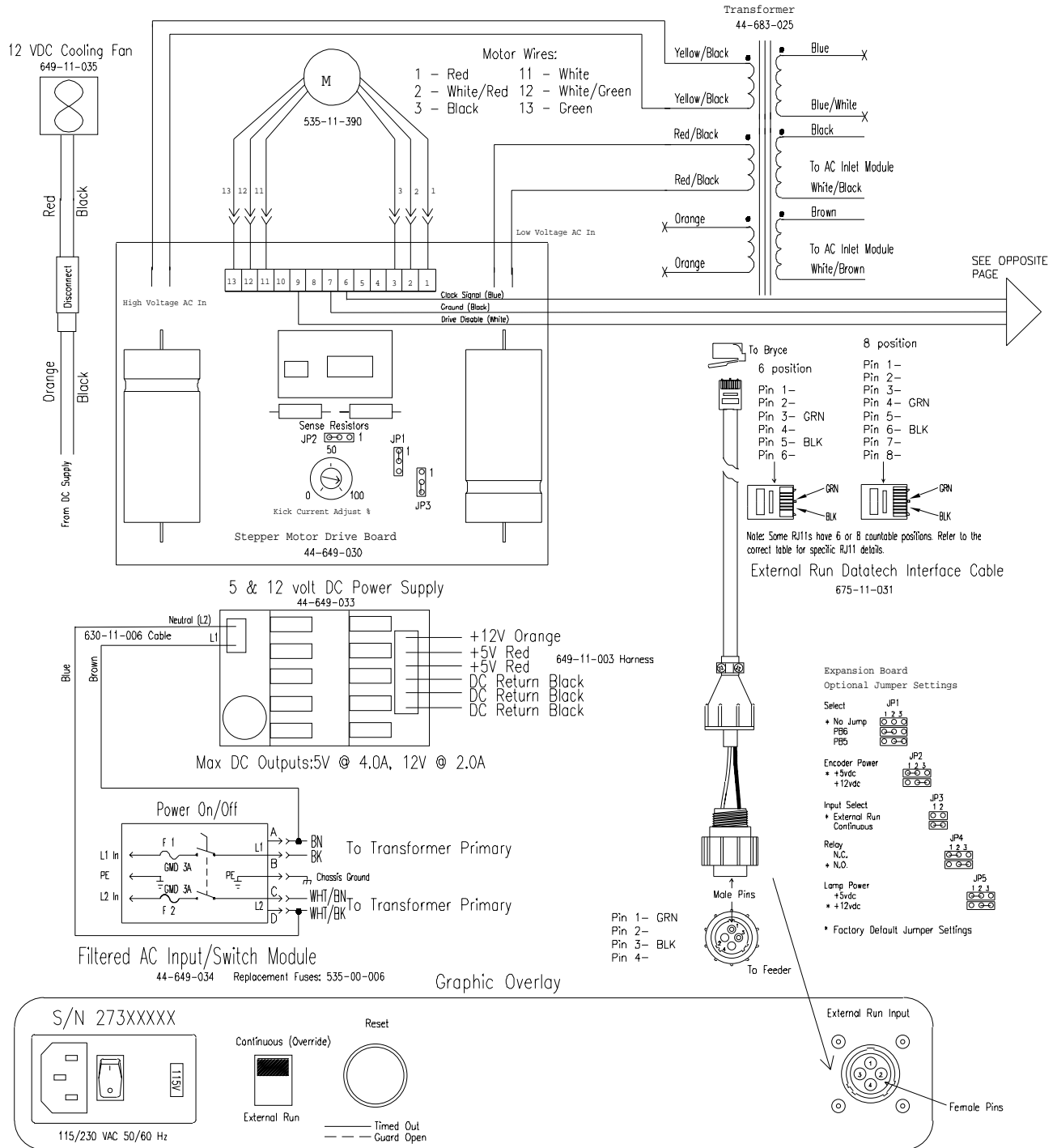

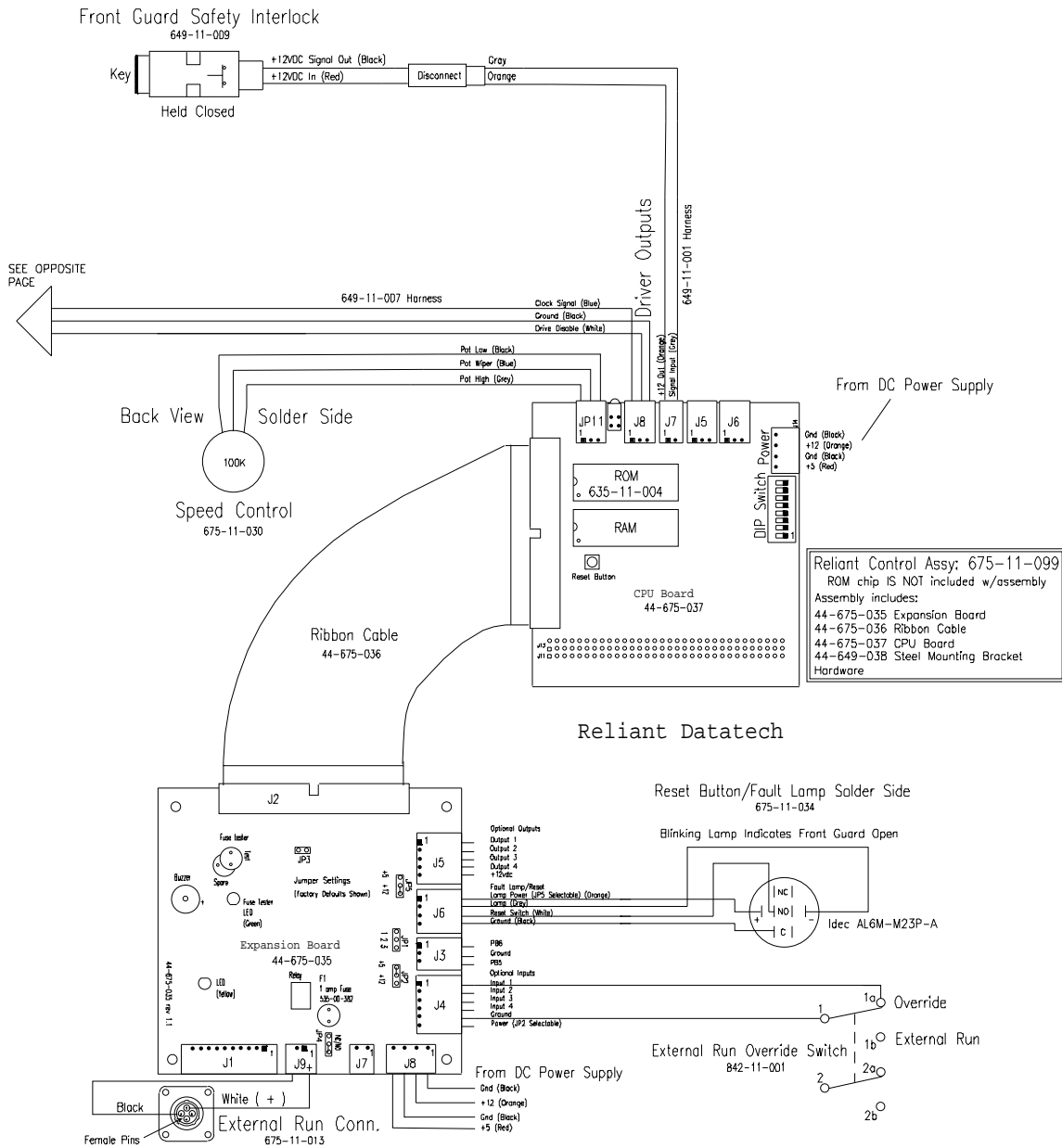

Reliant 2700 w/RSI Interface

12 VDC Cooling Fan
649-11-035

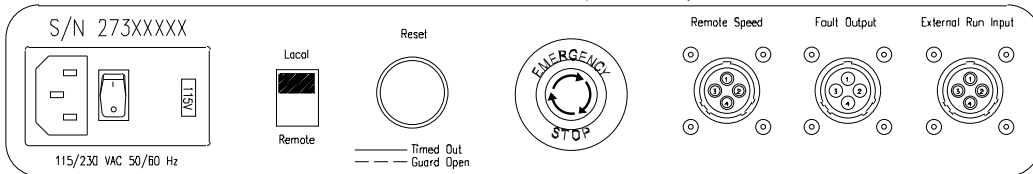
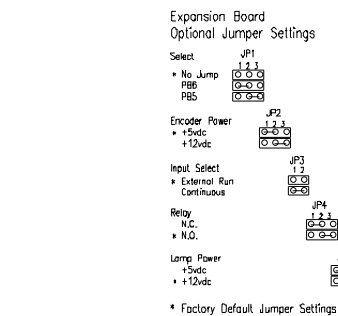
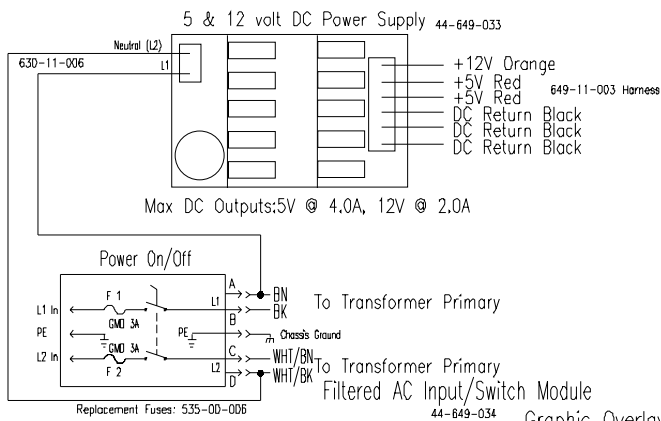
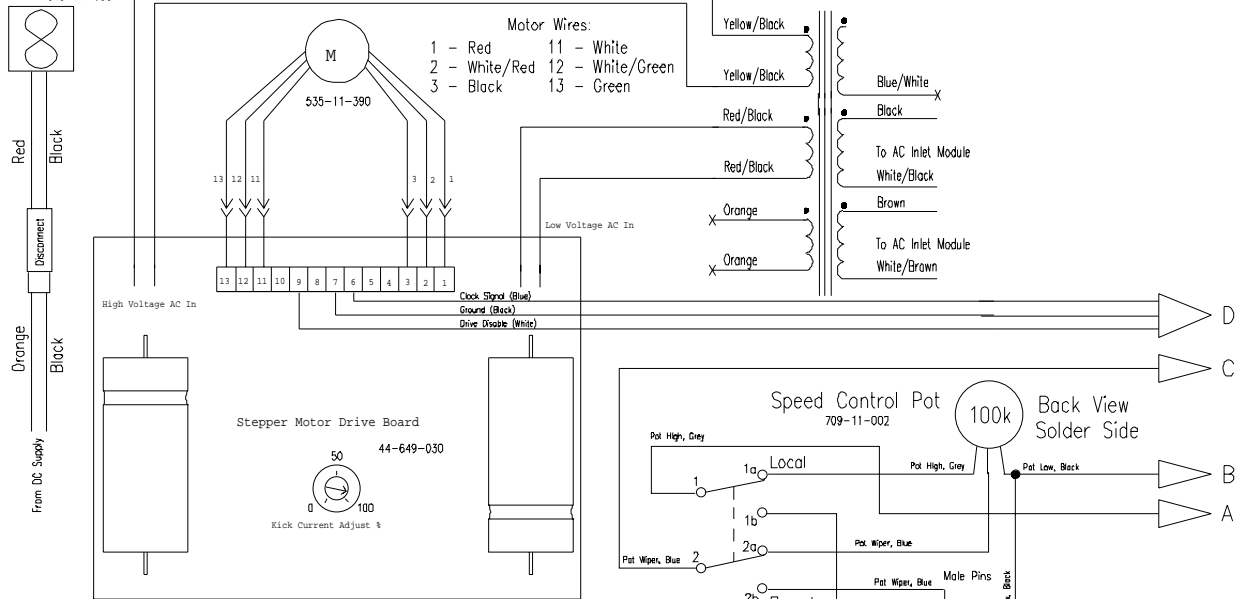

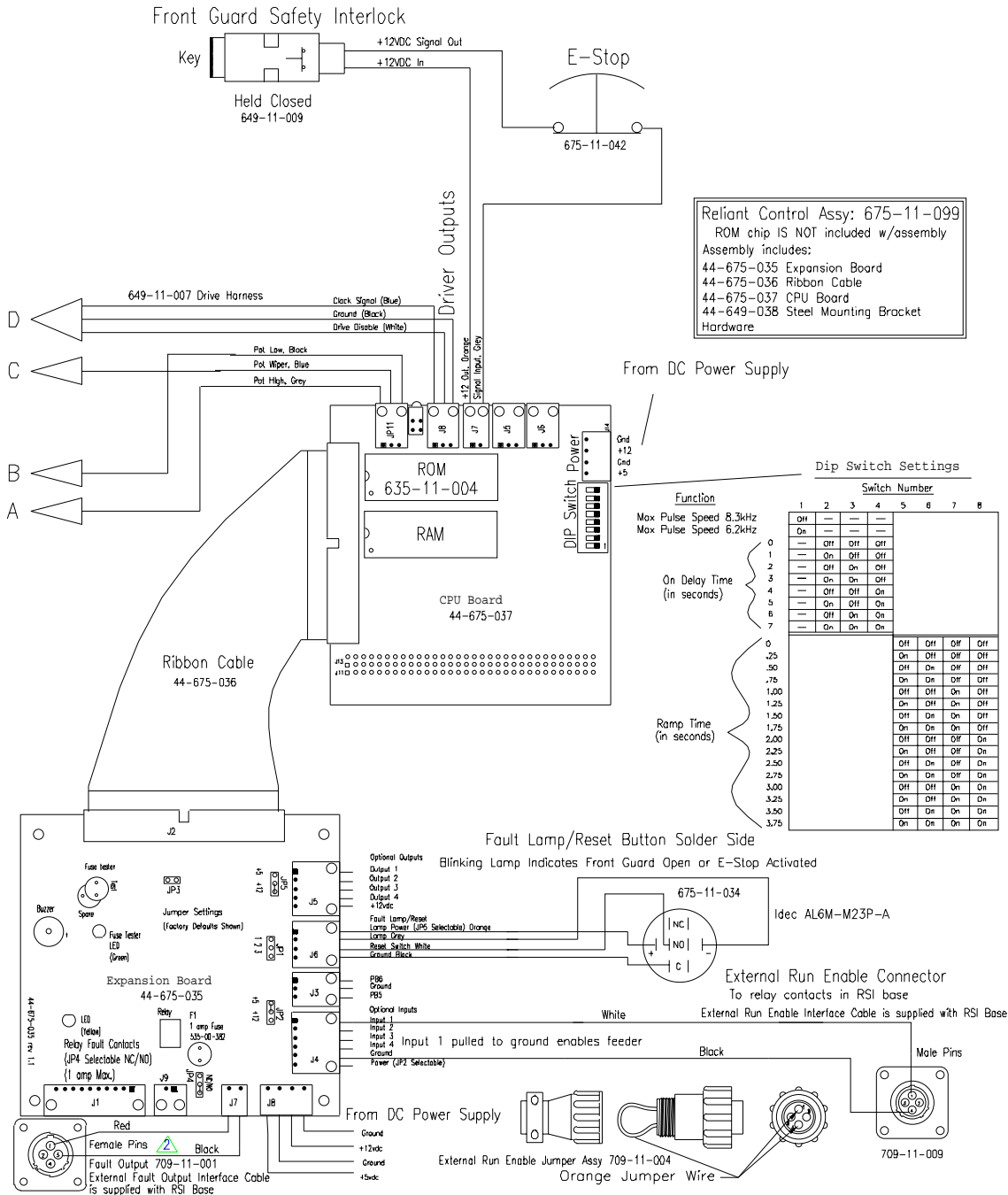

Warning:
 Improper Voltage Selection
 May Result In Permanent
 Damage To Feeder

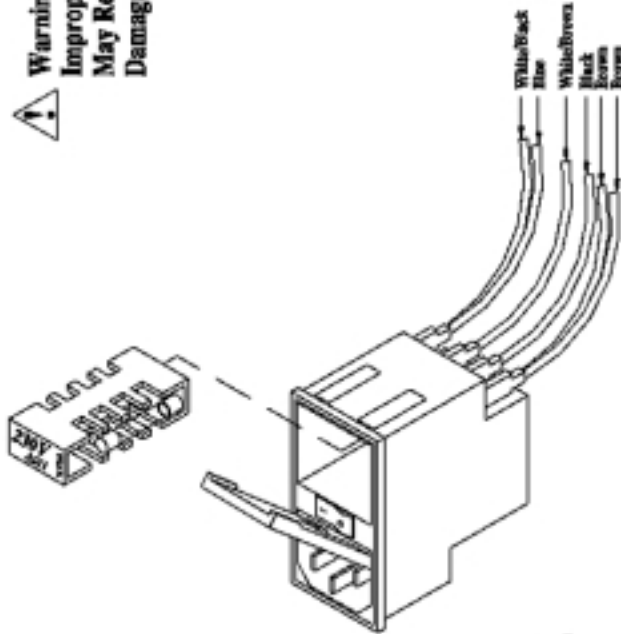

230 Volt Configuration

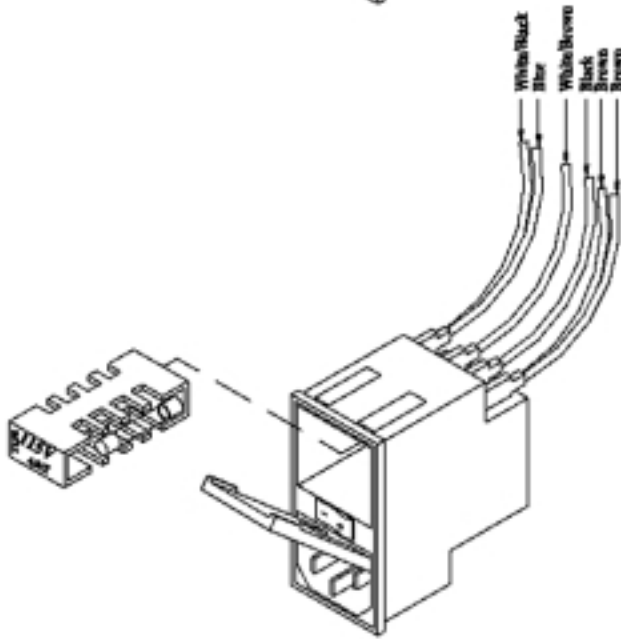

115 Volt Configuration



Mother Board Jumper Settings
(Factory Defaults)

JP1	RTC, DR00	1 2 3	RTC, Interrupt 2
JP2	Module 8, CPU 1	○ ○ ○	Module 8, CPU 2
JP3	Module 7, CPU 1	○ ○ ○	Module 7, CPU 2
JP4	Module 6, CPU 1	○ ○ ○	Module 6, CPU 2
JP5	Module 5, CPU 1	○ ○ ○	Module 5, CPU 2
JP6	Module 4, CPU 1	○ ○ ○	Module 4, CPU 2
JP7	Module 3, CPU 1	○ ○ ○	Module 3, CPU 2
JP8	Module 2, CPU 1	○ ○ ○	Module 2, CPU 2
JP9	Module 1, CPU 1	○ ○ ○	Module 1, CPU 2

JP14  Encoder0, 1K pull-down resistor

JP13	J20, NPN-Sinking	1 2 3	PNP-Sourcing
JP12	J19, NPN-Sinking	○ ○ ○	PNP-Sourcing
JP11	J5, NPN-Sinking	○ ○ ○	PNP-Sourcing
JP10	J2, NPN-Sinking	○ ○ ○	PNP-Sourcing

Note:

JP1 is not installed. If installed this jumper may conflict with the External trigger (Module 8) or (Module 6).

If Module 5 is used confirm Jumper JP14 on CPU is not installed.

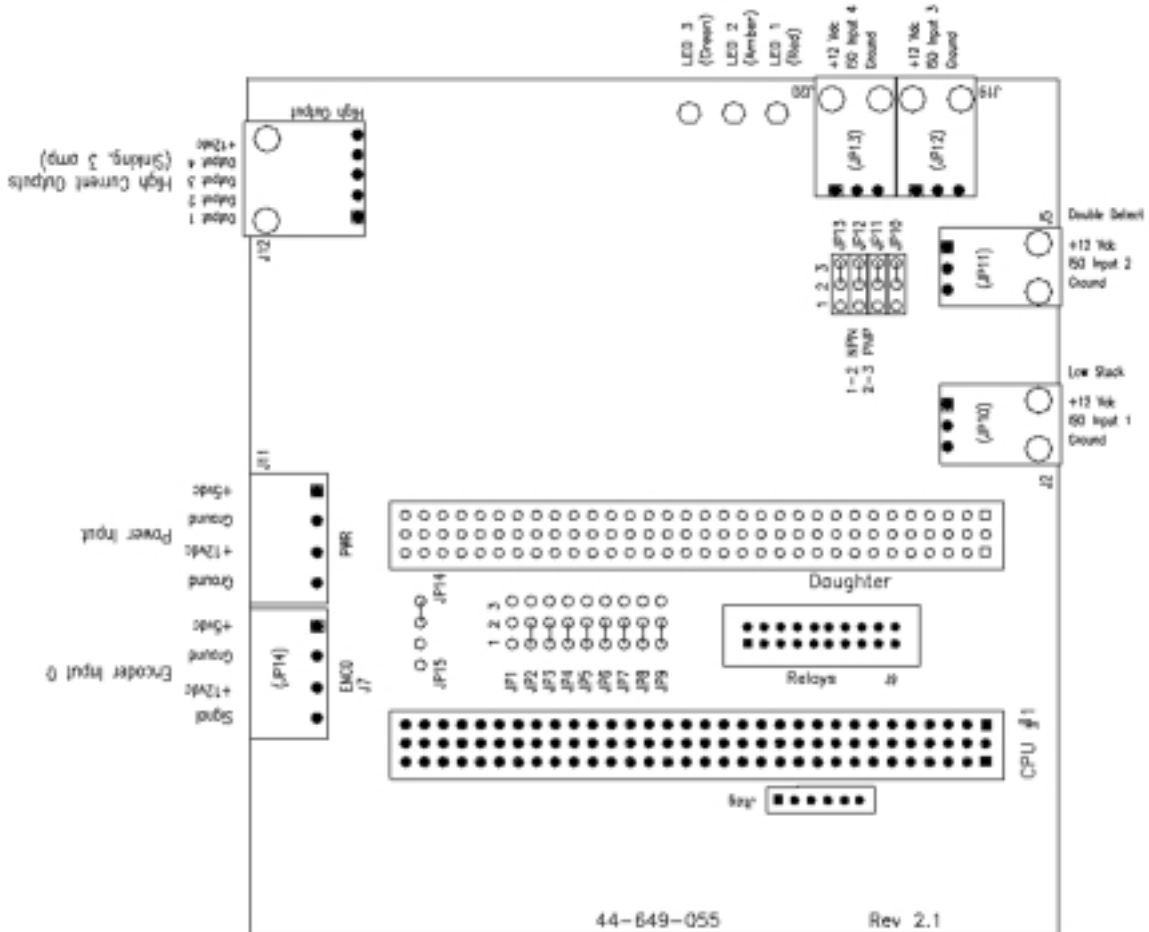

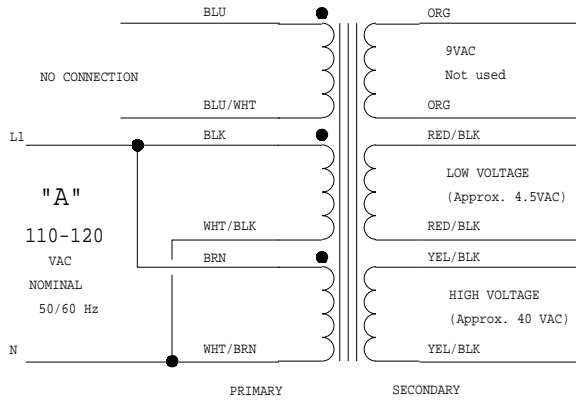

Standard wiring for most North American applications

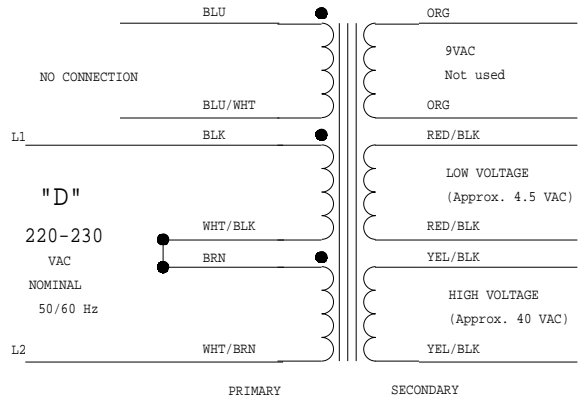

Standard wiring for Continental Europe, some 230V US applications

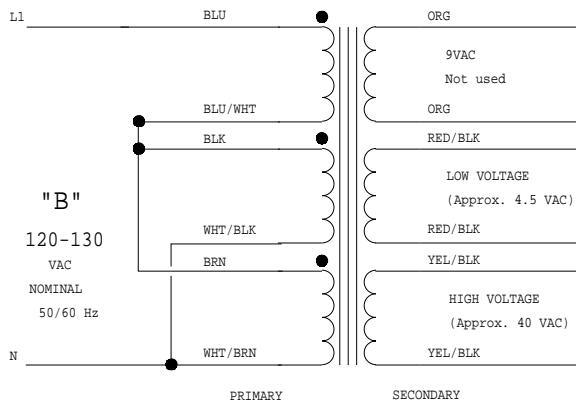

North America where voltage is over 120V

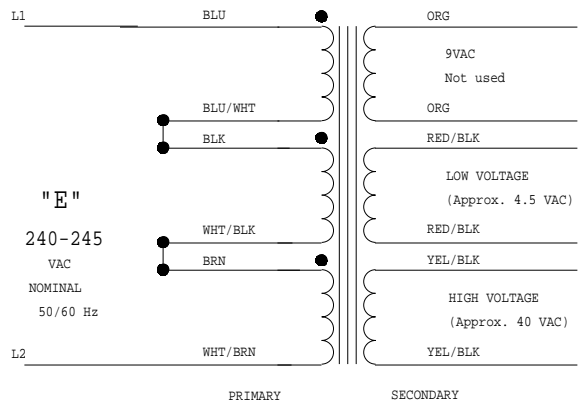

Standard wiring for U.K., Australia, New Zealand

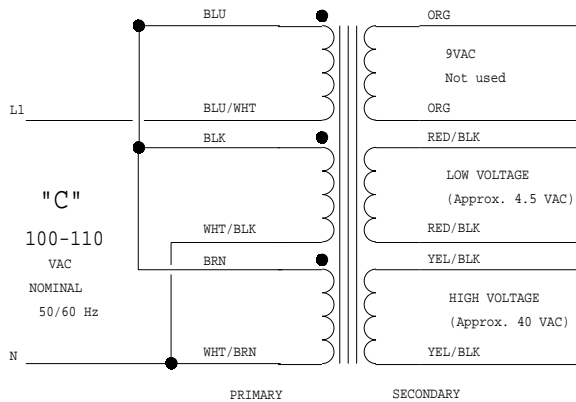

Standard wiring for Japan

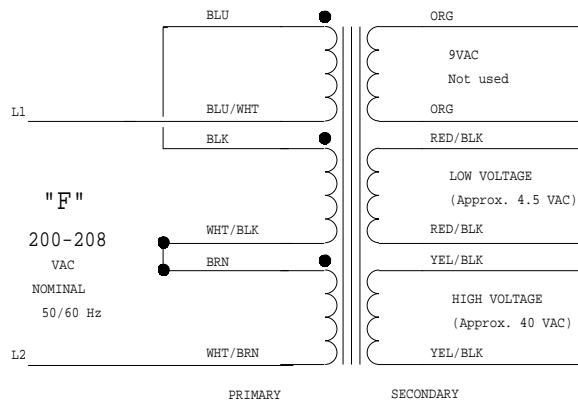

Some Japanese (200V) applications, some US applications for 208V

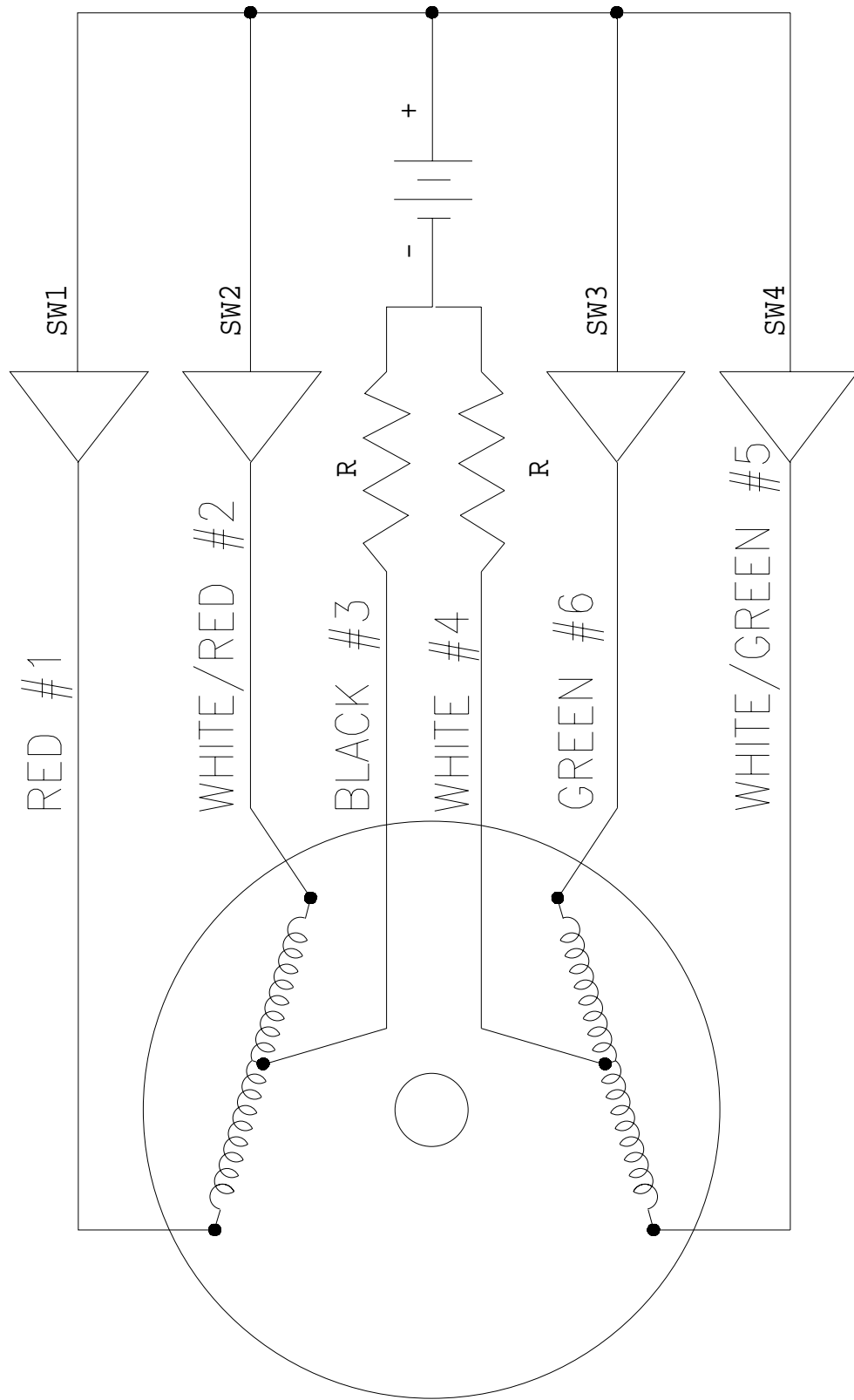

Unipolar DC Stepping Motor Drive Boards #44-649-030 and #535-00-467

13 Pin Motor Coupler Pin Assignments

- | | |
|-------------------------|-------------------------------|
| 1 - Motor Phase 1 | 8 - Not Used |
| 2 - Motor Phase 3 | 9 - Motor On/Off (Active Low) |
| 3 - Phases 1 & 3 Common | 10 - Not Used |
| 4 - Not Used | 11 - Phases 2 & 4 Common |
| 5 - Not Used | 12 - Motor Phase 2 |
| 6 - Clock Input | 13 - Motor Phase 4 |
| 7 - 0 VDC/Ground | |

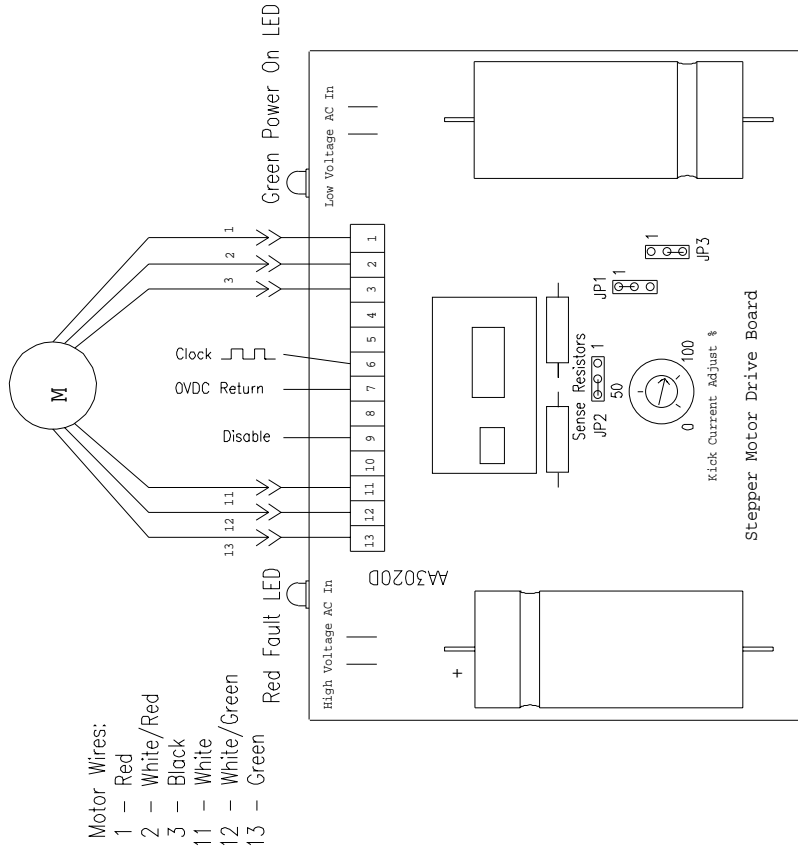

Motor Wires:

- 1 - Red
- 2 - White/Red
- 3 - Black
- 11 - White
- 12 - White/Green
- 13 - Green

Jumper Settings

Function	JP1	JP2	JP3
Negative Going Clocks	1 - 2	X	X
Positive Going Clocks	2 - 3	X	X
Terminal 5 = CCW	X	1 - 2	X
Terminal 5 = Direction	X	2 - 3	X
Fault Detection Enabled	X	X	2 - 3
Fault Detection Disabled	X	X	1 - 2
FACTORY DEFAULTS	1 - 2	2 - 3	2 - 3

Fault Detection Protection LED Indication

1	Red LED - Slow Blink	Short in Motor, Cable, or on Board
2	Red LED - Fast Blink	Open in Motor, Cable or on Board
3	Red LED - On Steady	Ground Fault (Voltage shorted to 0 volts)

NOTES - Drive is rated at 10 amps DC current max.
 Motor Kick Current Adjustment set at 85 - 90%.

Reliant 2700 DIP Switch Settings

Continuous Mode Only

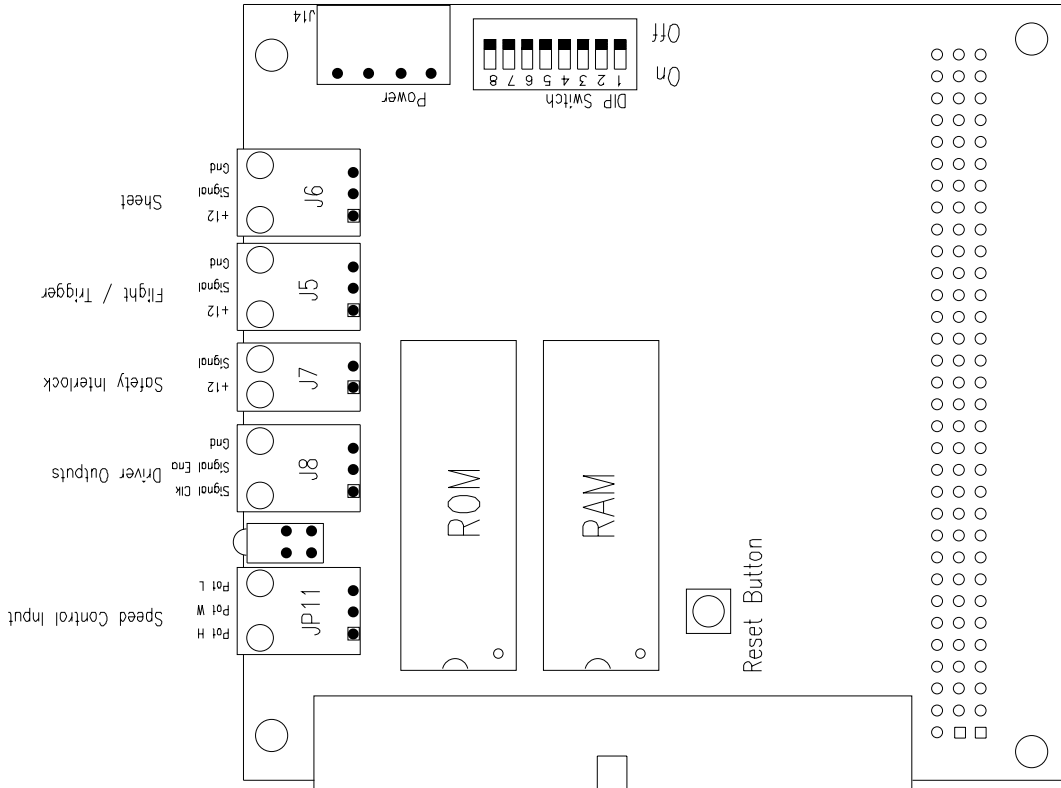

Function \ Switch	1	2	3	4	5	6	7	8
Max Speed 8300 Hz	Off							
Max Speed 6250 Hz	On							
0		Off	Off	Off				
1		On	Off	Off				
2		Off	On	Off				
3		On	On	Off				
4		Off	Off	On				
5		On	Off	On				
6		Off	On	On				
7		On	On	On				
Ramp Time (in seconds)								
0	Off	Off	Off	Off	Off	Off	Off	Off
.25	On	Off	Off	Off	Off	Off	Off	Off
.50	Off	On	Off	Off	Off	Off	Off	Off
.75	On	On	On	Off	Off	Off	Off	Off
1.00	Off	Off	On	On	Off	Off	Off	Off
1.25	On	On	Off	On	On	Off	Off	Off
1.50	Off	On	On	On	On	Off	Off	Off
1.75	On	On	On	On	On	Off	Off	Off
2.00	Off	Off	Off	Off	Off	On	On	On
2.25	On	On	On	On	On	Off	Off	Off
2.50	Off	Off	Off	Off	Off	On	On	On
2.75	On	On	On	On	On	Off	Off	Off
3.00	Off	Off	Off	Off	Off	On	On	On
3.25	On	On	On	On	On	Off	Off	Off
3.50	Off	Off	Off	Off	Off	On	On	On
3.75	On	On	On	On	On	Off	Off	Off

10 Technical Troubleshooting

General Troubleshooting Terms



Only a qualified technician should perform electrical troubleshooting activities. This unit operates on 115V or 230V electrical power. Bodily contact with these voltages can result in serious injury or death.

The “drive” consists of the AC power supply (transformer), the stepper motor drive board, and the motor. The “controls” consist of the DC power supply, the CPU board, any ribbon cables and wiring harnesses, and the sensors. Once it is determined that you have a drive or a controls problem, the next thing to check is the power supply for that section. The table that follows is designed to be a “quick lookup” for a problem you may be having. Wiring and board diagrams also contained in this manual are provided for reference and component recognition and connection during troubleshooting.

IMPORTANT

Reliant Models 2600 and 2700 have many various electrical control options available. To effectively troubleshoot you need to determine how your feeder has been configured. One or more of these options are installed during the manufacturing process because the machine is configured to order. Refer to the electrical wiring diagrams elsewhere in this manual. Here you will find the information that you need to determine the configuration of your machine.

To begin, remove the four screws securing the electrical component access cover. The speed control is mounted on this cover plate. Next look at the CPU board ROM label. This label has a few lines of text written on it. The top line of the text will have a number you should look for:

1. Number 63511003 indicates the machine has Dual Mode (continuous run and presentation mode) capabilities.
2. Number 63511004 indicates the machine has Continuous Mode capability only.
3. Number 63511005 indicates the machine has Presentation Mode capability only.

If any other number appears on the top line, your machine is not a factory standard, and has custom controls. If this is the case, contact the dealer through which you purchased the machine for further details.

TIP

Many of the wiring harnesses have numbered labels on them. Try to match the harness numbers to help you determine the option(s) you have.

TIP

If your machine has a sheet detect sensor, it has either Presentation or Dual Mode controls. If your machine does not have a sheet detect sensor, it has Continuous Mode controls.

Next look at the graphic overlay on your machine. This overlay has a serial number printed on it near the power switch. The wiring diagrams show a representation of the graphic overlay associated with that machine. Try to find the overlay drawing that most closely matches your machine.

You may need to use a combination of two diagrams depending upon the options you may have. For example: You have determined from the ROM label that your machine has Dual Mode capabilities. The first document you will use for reference is the one titled *Reliant Dual Mode w/o External Run Option*. From this document you see that the graphic overlay may or may not match the overlay on your machine. Does your machine have an External Run Input connector? If so, look at the Dual Mode option diagrams that follow. There are several external run options available. You will need to look at the wiring to determine which option you have.

The table that follows is designed to be a “quick lookup” for a problem you may be having. Wiring and board diagrams also contained in this manual are provided for reference and component recognition and connection during troubleshooting.

Table 10-1. Quick-Look Troubleshooting



Problem	Solution
<p>No power to feeder when power switch is turned on</p> <div data-bbox="181 499 328 562" style="border: 1px solid black; padding: 2px;">  NOTE </div> <p><i>This power module is designed to hold 5mm x 20mm fuses, as well as 1.25" x .25" fuses. The machine ships from Streamfeeder's facility with 5mm x 20mm fuses.</i></p>	<ol style="list-style-type: none"> 1. Make sure there is power present at the AC main where the feeder is plugged in. 2. Check three-wire AC power cord for integrity at all three points. 3. Remove power cord from AC input switch module and disconnect the four space connector leads located on the back of the module inside the feeder. 4. Check the two fuses located inside the feeder's input power module. BOTH fuses must be present and test good. <ol style="list-style-type: none"> a. Observe the voltage label showing through the window on the fuse housing for the proper orientation when the holder is re-inserted. b. A small screwdriver inserted under the tab will allow you to pry open the fuse housing. Remove the red fuse holder. If the smaller 5mm x 20mm fuse is present, verify that the metal tab "finger" is holding the fuse in the forward position. Make sure it has not allowed the fuse to slide back toward the outside of the feeder and away from where contact with the metal pressure points inside the module body is made. c. Use an ohmmeter to test the fuses. A visual inspection will not always be sufficient to determine fuse integrity. If necessary, replace with fuses of the same rating only. 5. Reconnect power cable and, with power switch turned "on," check for presence of AC at the output spade connectors on the back of the module where the transformer primary lead connections are made. 6. If steady AC power is not measured as in the previous step, the module's internal contacts are most likely worn, and the module must be replaced.
<p>Fuses blow on power up</p> <div data-bbox="181 1234 328 1297" style="border: 1px solid black; padding: 2px;">  NOTE </div> <p><i>A fuse failure indicates a problem with the last item connected before failure occurs.</i></p>	<ol style="list-style-type: none"> 1. Install known good fuses of same rating only. 2. Disconnect all AC loads from the input: <ol style="list-style-type: none"> a. The transformer primary. b. The DC supply's AC input leads. c. Remove the red and yellow wire pairs from the stepper motor drive board. 3. Reconnect AC loads one item at a time while alternately applying power between new connections. Connect each load as follows one at a time to determine the faulty part: <ol style="list-style-type: none"> a. Connect the transformer primary leads to the AC input module. b. Connect leads to the two-pin AC input connector of the DC power supply. c. Connect the red and yellow wire pairs of the transformer secondary to the stepper motor drive board.

Table 10-1. Quick-Look Troubleshooting (continued)





Problem	Solution
<p>Decreased power experienced after fuse is replaced</p>  <p><i>Never apply more than 125V when the fuse holder is in the 115V position. Applying 230V to the feeder when the fuse holder is in the 115V position will damage the feeder's internal electronics.</i></p>	<p>If the input power module fuse holder is installed in the 230V position, and the line power is at 115V, the feeder will have noticeably decreased power.</p>
<p>Decreased power experienced after drive board is replaced</p>	<p>The drive board must have its “kick current” dial set to at least 90%.</p>
<p>Motor does not run, is noisy, makes a “growling” sound, or runs in reverse</p>  <p>NOTE</p> <p><i>A digital multimeter with frequency measurement capabilities is necessary for the following tests. If your meter does not have the ability to make a frequency measurement, an oscilloscope may be used instead.</i></p>  <p>NOTE</p> <p><i>This test requires a meter that has frequency measurement capabilities, or an oscilloscope.</i></p>  <p>NOTE</p> <p><i>The frequency measured here directly affects the speed of the motor.</i></p>	<ol style="list-style-type: none"> 1. Verify green LED on the stepper motor drive board is illuminated. If not, verify transformer secondary leads measure correct voltages: 40 VAC across yellow pair of wires, and 4.5 VAC across red pair of wires. Go to section titled “Testing the transformer” for further information. If green LED is not illuminated and the transformer voltages test good, replace drive board. Otherwise, continue with next step. 2. Look at the red LED on the stepper motor drive board. Is it illuminated? <ol style="list-style-type: none"> a. If yes, go to section titled “Drive board red LED illuminated”. b. If no, continue with next step. 3. Remove white wire from pin 9 of the stepper motor drive board 13-pin connector. This is the drive disable line coming FROM the CPU board on connector J8 pin 2. The drive board is enabled by default when no connection is made at pin 9. 4. Cycle the feeder. If the motor runs, the output on connector J8 pin 2 of the CPU board is bad, and the CPU board must be replaced. If not, continue with next step. 5. Measure for the presence of pulse train. The pulse train comes FROM the CPU board connector J8 pins 1 (signal) and 3 (ground), and goes TO the stepper motor drive board at pins 6 (signal input) and 7 (ground). Test points are pins 6 and 7 on the 13-terminal connector to the drive board. <ol style="list-style-type: none"> a. Power-up the feeder and verify the reset button is not illuminated. If a reset cannot be accomplished refer to the section titled “On/Off beeping sound is heard, reset button is illuminated, and pressing button does not reset fault”. b. Verify signal is present on pins 6 and 7. When the speed control knob is fully CCW, no pulse or a very low pulse frequency will be measured. When the speed control is fully CW, the frequency could be measured as high as 8.2 kHz. It is recommended to set the run speed at about 50% where the frequency measured should be somewhere between 3000 and 4000 Hz.

Table 10-1. Quick-Look Troubleshooting (continued)

Problem	Solution
<p>Motor does not run, is noisy, makes a “growling” sound, or runs in reverse (continued)</p>	<ul style="list-style-type: none"> c. Check integrity of both ends of drive wiring harness between the CPU board connector J8 and the 13-terminal connector to the drive board. d. Using a digital multimeter or an oscilloscope, measure the amplitude of the pulse train and verify that it is at least 2.3VDC. e. If pulse test results are good, replace the stepper motor drive board. If the pulse tests results are negative, the pulse output on connector J8 of the CPU board is bad, and the control assembly must be replaced.
<p>Drive board red LED illuminated</p> <div style="border: 1px solid black; padding: 2px; width: fit-content; margin: 5px 0;">IMPORTANT</div> <p><i>The stepper motor drive board has been designed to protect itself if motor problems occur. If a problem with the motor wires or motor is found and corrected, the board will still drive a good motor after correction is made. However, the board cannot protect itself from transient voltage spikes and/or power sags or brownouts. It is highly recommended that in plants where power problems are evident or in question, a high quality surge suppressor or line conditioner should be employed for added protection.</i></p>	<ul style="list-style-type: none"> 1. Slow Blink: (about once per second) indicates a SHORT in motor, motor cable, or drive power component. <ul style="list-style-type: none"> a. Check integrity of motor wires and/or cable. None of the wires should be exposed, and should have their full insulation so that they may not short to each other or any other part of the machine. b. If wires look OK, go to section titled “Testing stepper motor drive board output pins.” c. If stepper motor drive board test results are positive, replace the motor. For further information, see the section titled “Testing motors.” 2. Fast Blink: (multiple times per second) indicates an OPEN in motor, motor cable, or drive component. <ul style="list-style-type: none"> a. Check integrity of motor wires and/or cable. None of the wires should measure open, or be disconnected or loose from their terminals. b. If wires check OK, go to section titled “Testing stepper motor drive board output pins.” c. If stepper motor drive board test results are positive, replace the motor. For further information, see the section titled “Testing motors.” 3. On Steady: indicates a ground fault (wire shorted to zero volts). <ul style="list-style-type: none"> a. Remove ground fault.
<p>Testing stepper motor drive board output pins</p> <div style="border: 1px solid black; padding: 2px; width: fit-content; margin: 5px 0;"> NOTE</div> <p><i>A digital multimeter is required for these tests.</i></p> <div style="border: 1px solid black; padding: 2px; width: fit-content; margin: 5px 0;"> NOTE</div> <p><i>Measuring zero volts drop across one of these pins may be evidenced by blowing fuses on power-up. See section titled “Fuses blow on power up”.</i></p>	<ul style="list-style-type: none"> 1. Remove 13-terminal plug-in motor wire coupler from the drive board. 2. Test motor phase pins. Note: A digital multimeter is required for these tests. <ul style="list-style-type: none"> a. Set the multimeter to Diode Test. b. Place the RED meter lead on one of the leads between the large black sense resistors located at the center of the drive board located above jumper JP2. c. Touch the BLACK meter lead to each phase terminal (pins 1, 2, 12, and 13). This should give readings between 0.450V and 0.550V. If any readings are significantly greater than or less than 0.450V to 0.55V, then the unit is faulty and must be replaced. 3. Test motor common pins: <ul style="list-style-type: none"> a. Touch the BLACK meter lead to the positive lead of the large blue capacitor on the left side of the board, which is located below the red fault indicator LED. b. Touch the RED meter lead to pins 3 and 11. These pins should give readings between 0.450V and 0.550V. If any readings are significantly greater than or less than 0.450V to 0.55V, then the unit is faulty and must be replaced.

Table 10-1. Quick-Look Troubleshooting (continued)

Problem	Solution
<p>Fan does not operate/ Testing DC power supply</p> <p>NOTE <i>The DC supply has dual outputs: 5 and 12 volts DC.</i></p> <p>NOTE <i>When the output is shorted, a faintly audible clicking sound can be heard coming from the supply. This is the power supply protecting itself from failure due to a short on its output.</i></p> <p>IMPORTANT <i>Continued operation of the machine without the cooling fan working properly will cause further damage to the internal electronic components.</i></p>	<ol style="list-style-type: none"> 1. Refer to the DC power supply board diagram. Remove 6-pin DC wiring harness connector from output of DC supply. Measure the supply's output pins for the presence of DC power. <ol style="list-style-type: none"> a. If voltages are not present, verify AC power is being applied to AC input. b. Also check the fuse on the supply's AC input. If the fuse is bad, and replacing it causes fuse failure to occur again, replace the supply. c. If the fuse is good, AC power is being applied, and DC power cannot be measured, replace supply. 2. Verify good electrical connections to pins in DC wiring harness 6-pin quick disconnect plug. Reconnect harness. 3. Check for shorted wires in the DC wiring harness on output of supply. A short will cause the supply to shut down. The power supply should operate normally after the short is removed. 4. Test DC wire harness 4-pin plug in connectors to the CPU and Expansion Boards for the presence of 5 and 12 volts DC. 5. Test wire harness to fan quick-disconnect plug for the presence of 12VDC. 6. Replace fan.
<p>CPU board "heartbeat" pulse not present</p>	<ol style="list-style-type: none"> 1. Two LEDs are located on the CPU board. The "heartbeat" LED is the green LED. The green LED should blink at regular intervals under normal operation when the feeder is powered on. Make sure the front safety shield is closed completely, and that no error conditions are present. 2. Check output of DC power supply. See section titled "Fan does not operate/Testing DC power supply." 3. Verify ribbon cable integrity between CPU board and Expansion Board. 4. Check that the ROM and RAM chips are seated properly in their sockets. Improperly seated chips may cause the CPU board to indicate a problem by illuminating the red LED located next to the green "heartbeat" LED. The red LED should not illuminate. 5. Replace Reliant Control Assembly. 6. Replace ROM chip.

Table 10-1. Quick-Look Troubleshooting (continued)





Problem	Solution
<p>On/Off beeping sound is heard, reset button blinks, and pressing button does not reset fault</p> <p> NOTE <i>Power must be on during the following tests. Exercise caution.</i></p> <p> NOTE <i>The following steps assume the output of the DC power supply is working and both 5 and 12 volts is present at the CPU and Expansion Board input connectors.</i></p> <p> NOTE <i>The following steps assume the blinking green "heartbeat" LED is present on the CPU board. If not, see section titled "CPU board 'heartbeat' pulse not present."</i></p>	<ol style="list-style-type: none"> 1. Remove reset button harness from Expansion Board connector J6. 2. Using a small metal blade screwdriver, short pins 3 and 4 together on Expansion Board connector J6. 3. Did shorting these pins reset the feeder? <ol style="list-style-type: none"> a. Yes: The reset switch harness assembly is faulty. Repair or replace as necessary. b. No: Verify continuity at reset button closure, reconnect the reset button harness to the Expansion Board connector J6. Press the reset button after trying each of the following steps: 4. Verify that the discharge safety shield is closed completely. 5. Is E-Stop option installed? <ol style="list-style-type: none"> a. Yes: Go to step 6. b. No: Go to step 7. 6. Verify E-Stop switch is out of the locking stop position by twisting and pulling the red knob out. 7. Remove the safety interlock harness from connector J7 of the CPU board. 8. Using a small metal blade screwdriver, short pins 1 and 2 together on CPU board connector J7, keep them shorted, and press the reset button. Does pressing the reset button reset feeder? <ol style="list-style-type: none"> a. Yes: Go to step 9. b. No: Go to step 10. 9. Connector J7 input is good. Check the integrity of safety interlock harnesses and the safety interlock switch. If E-Stop option is installed, check the integrity of this harness and switch assembly as well. Repair or replace as necessary. 10. Replace Reliant Control Assembly. 11. Replace ROM chip.
<p>Steady beep is heard, reset button is illuminated, and pressing button does not reset fault</p> <p> NOTE <i>Power must be on during the following tests. Exercise caution.</i></p>	<ol style="list-style-type: none"> 1. Verify firm connection and that the integrity of the ribbon cable connected between the CPU and Expansion Boards is intact. 2. Remove reset button harness from Expansion Board connector J6. 3. Using a small metal blade screwdriver, short pins 3 and 4 together on Expansion Board connector J6. Did shorting these pins reset the feeder? <ol style="list-style-type: none"> a. Yes: The reset switch harness assembly is faulty. Repair or replace as necessary. b. No: Verify reset switch integrity, reconnect to Expansion Board connector J6 and go to step 4.

Table 10-1. Quick-Look Troubleshooting (continued)



Problem	Solution
<p>Steady beep is heard, reset button is illuminated, and pressing button does not reset fault (continued)</p> <p> NOTE <i>These steps only apply to Presentation Mode machines or Dual Mode machines working in the Presentation Mode.</i></p> <p> NOTE <i>The following steps assume the output of the DC power supply is working and both 5 and 12 volts is present at the CPU and Expansion Board input connectors. If not, see section titled "Fan does not operate/Testing DC power supply."</i></p> <p> NOTE <i>The following steps assume the blinking green "heartbeat" LED is present on the CPU board. If not, see section titled "CPU board "heartbeat" pulse not present."</i></p>	<ol style="list-style-type: none"> 4. Verify the sheet sensor's power-on green LED is illuminated. Is the green LED illuminated? <ol style="list-style-type: none"> a. Yes: Go to step 5. b. No: Go to step 7. 5. Verify the sheet sensor's yellow LED sensing indicator illuminates when the sensor is covered, and goes dark when the sensor is uncovered. Is the yellow LED illuminated when the sheet sensor is covered, and dark when the sensor is uncovered? <ol style="list-style-type: none"> a. Yes: Go to step 6. b. No: Go to step 7. 6. Cover the sensor so that the yellow sensing LED is illuminated and press the reset switch. Did the feeder reset? <ol style="list-style-type: none"> a. Yes: The feeder times-out as it should. Go through feeder setup and make sure the sensor sees the leading edge of the next sheet shortly after a piece of sheet material is removed from the feeder. If the leading edge of the next piece of material is not detected in time, the feeder "times-out" and stops, causing the steady audible beep and reset button lamp to illuminate. b. No: Got to step 7. 7. Remove the sheet detect sensor harness from CPU connector J6 and measure for the presence of 12VDC across pins 1 and 3 of connector J6 on the board. Is the voltage present? <ol style="list-style-type: none"> a. Yes: Go to step 8. b. No: Go to step 9. 8. Test sheet sensor input. Using a small metal blade screwdriver, short pins 1 and 2 together on CPU board connector J6, keep them shorted, and press the reset button. Does the feeder reset? <ol style="list-style-type: none"> a. Yes: The sheet sensor input on the CPU board is good. Repair faulty sheet sensor harness and/or replace sheet sensor. b. No: Go to step 9. 9. Replace Reliant Control Assembly. 10. Replace ROM chip.

Table 10-1. Quick-Look Troubleshooting (continued)

Problem	Solution
<p>Testing the External Run Dry Contact input</p>	<p><u>Dual Mode machines:</u></p> <ol style="list-style-type: none"> 1. External Run only functions in Continuous Mode. Verify mode switch is not set for Presentation Mode. 2. Verify jumper block JP3 is removed from the expansion board. 3. Verify the integrity of the mode selector switch and harness, and that it is closed across pins 1 and 2 of connector J3 on the Expansion Board. 4. Shorting pin 1 to pin 5 of connector J4 on the Expansion Board should cause the feeder to run. If not, replace the Reliant Control Assembly. <p><u>Continuous Mode machines:</u></p> <ol style="list-style-type: none"> 1. Verify jumper block JP3 is removed from the expansion board. 2. Verify the integrity of the Y adapter harness and the external run override switch and harness. Verify that the switch opens and closes across pins 1 and 5 of connector J4 on the Expansion Board. 3. Shorting pin 1 to pin 5 of connector J4 on the Expansion Board should cause the feeder to run. If not, replace the Reliant Control Assembly.
<p>Testing the External Run input 3-28 volts DC</p>	<p><u>Dual Mode machines:</u></p> <ol style="list-style-type: none"> 1. External Run only functions in Continuous Mode. Verify mode switch is not set for Presentation Mode. 2. Verify jumper block JP3 is removed from the expansion board. 3. Verify the integrity of the mode selector switch and harness, and that it is closed across pins 1 and 2 of connector J3 on the Expansion Board. 4. Applying a voltage between 3 and 28 VDC to connector J9 on the Expansion Board should cause the feeder to run. If not, replace the Reliant Control Assembly. If a power supply is not available to you, you may test the input using a 9V battery. To test the input using a 9V battery: <ol style="list-style-type: none"> a. Connect the positive terminal of the battery to pin 1 of connector J9. b. Connect the negative terminal of the battery to pin 2 of connector J9. <p><u>Continuous Mode machines:</u></p> <ol style="list-style-type: none"> 1. Verify jumper block JP3 is removed from the expansion board. 2. Verify the integrity of the Y adapter harness and the external run override switch and harness. Verify that the switch opens and closes across pins 1 and 5 of connector J4 on the Expansion Board.

Table 10-1. Quick-Look Troubleshooting (continued)

Problem	Solution
<p>Testing the External Run input 3-28 volts DC (continued)</p>	<ol style="list-style-type: none"> 3. With the override switch open, apply a voltage between 3 and 28 VDC to connector J9 on the Expansion Board. This should cause the feeder to run. If not, replace the Reliant Control Assembly. If a power supply is not available to you, you may test the input using a 9V battery. To test the input using a 9V battery: <ol style="list-style-type: none"> a. Connect the positive terminal of the battery to pin 1 of connector J9. b. Connect the negative terminal of the battery to pin 2 of connector J9. 4. With the override switch closed, remove the voltage from Expansion Board connector J9. The override switch shorts pin 1 to pin 5 of connector J4 on the Expansion Board. This should cause the feeder to run. If not, replace the Reliant Control Assembly.
<p>Testing the Powered External Run Input</p>	<p><u>Dual Mode machines:</u></p> <ol style="list-style-type: none"> 1. Verify jumper block JP3 is removed from the expansion board. 2. Verify the integrity of the mode selector switch and harness, and that it is closed across pins 1 and 2 of connector J3 on the Expansion Board. 3. Locate the mechanical relay mounted inside the machine. Determine the voltage of the coil by looking at the label on the relay body. Three possible relays may be found: <ol style="list-style-type: none"> a. 24VAC. b. 120VAC. c. 230VAC. 4. Apply the proper voltage to the coil of the relay and listen for contact closure. If the relay contacts do not pull in, replace the relay. 5. Verify contact continuity where the white and black wires are connected to the contact side of the relay. These wires are also connected to the Expansion Board connector J4 across pins 1 and 5. If the contacts or wire leads are bad, continuity cannot be measured. Replace wire leads or replace the relay as necessary. 6. The relay contacts are meant to short pin 1 to pin 5 of connector J4 on the Expansion Board. This should cause the feeder to run. If not, replace the Reliant Control Assembly. <p><u>Continuous Mode machines:</u></p> <ol style="list-style-type: none"> 1. Verify jumper block JP3 is removed from the expansion board. 2. Verify the integrity of the Y adapter harness and the external run override switch and harness. Verify that the switch opens and closes across pins 1 and 5 of connector J4 on the Expansion Board. 3. Locate the mechanical relay mounted inside the machine. Determine the voltage of the coil by looking at the label on the relay body. Three possible relays may be found: <ol style="list-style-type: none"> a. 24VAC. b. 120VAC. c. 230VAC.

Table 10-1. Quick-Look Troubleshooting (continued)

Problem	Solution
<p>Testing the Powered External Run Input (continued)</p>	<ol style="list-style-type: none"> 4. With the override switch open, apply the proper voltage to the coil of the relay and listen for contact closure. If the relay contacts do not pull in, replace the relay. 5. Verify contact continuity where the white and black wires are connected to the contact side of the relay. These wires are also connected to the Expansion Board connector J4 across pins 1 and 5. If the contacts or wire leads are bad, continuity cannot be measured. Replace wire leads or replace the relay as necessary. 6. The relay contacts are meant to short pin 1 to pin 5 of connector J4 on the Expansion Board. This should cause the feeder to run. If not, replace the Reliant Control Assembly. 7. Closing the override switch simply replaces the relay contact closure. This should short pin 1 to pin 5 of connector J4 on the Expansion Board, and cause the feeder to run. If not, replace the Reliant Control Assembly.
<p>Testing the Fault Output Connector</p>	<ol style="list-style-type: none"> 1. Remove fuse F1 from the Expansion Board and measure across its pins for continuity. If continuity is not measured, replace the fuse. 2. Fuse F1 is connected in series with a set of contacts inside the mini relay located on the Expansion Board. These contacts are brought out through connector J7. Jumper block JP4 selects the normally open or normally closed set of contacts. The normally open contacts close when the machine is powered on. Test the contacts: <ol style="list-style-type: none"> a. Set jumper block JP4 in the N.O. position b. Using an ohmmeter, measure across pins 1 and 2 of connector J7. You should measure an open load. c. Power on the machine. The contacts should close and you should measure continuity across J7. If not, replace the Expansion Board.
<p>Testing Motors</p>	<p>Refer to the wiring diagram of the 6-lead DC Stepping Motor found elsewhere in this manual.</p> <p>These motors are NOT repairable, and should never be opened.</p> <p>The motors used in the Reliant Series of feeders have two windings: three leads associated with each winding, for a total of six leads. Each winding has a wire at each end of the winding, with a wire connected also at the center of the winding. This center tap is also called the “common” wire, while the end wires are called the “phase” wires. Motors are inductors. Inductors are tough to troubleshoot unless there is a catastrophic failure associated with the windings inside the inductor. An ohmmeter may be used to test for catastrophic failures, but is useless when a motor has a problem that is not catastrophic. Therefore, a motor can still have a problem even though it appears there is not a problem as measured with an ohmmeter. The following are tests that you can make with an ohmmeter:</p> <ol style="list-style-type: none"> 1. All three leads of each individual winding should measure continuity in any combination of two. Conversely, an OPEN should NOT be measured in any combination of two of the three leads tested in a single winding. If an open is measured in a single winding, it is a clear indication that the motor is bad and needs to be replaced. 2. Since there are two separate windings, they need to measure electrically separate

Table 10-1. Quick-Look Troubleshooting (continued)

Problem	Solution
<p>Testing Motors (continued)</p>	<p>from each other. That is, any combination of one lead from one winding to any lead of the other winding should measure as OPEN. If a short is measured between windings, it is a catastrophic failure inside the motor, and it must be replaced.</p> <p>3. Both windings need to be insulated from the body of the motor. If continuity is measured between any motor lead and the body of the motor, a catastrophic failure has occurred inside the motor and it must be replaced.</p>
<p>Testing the Transformer</p>	<p>Refer to the wiring diagram of the Reliant Series Transformer found elsewhere in this manual. Note that there are three primary windings and also three secondary windings: six windings altogether. Most feeders are shipped from Streamfeeder's facility with the transformer set up for configurations "A" and "D." Therefore one of the primary windings is not used, and will be tied back. (The orange secondary leads are also not used in the Reliant Series of feeders, and will be tied back). Flipping the fuse holder around in the AC power entry module will set up the feeder for either 115VAC as shown in configuration "A," or for 230VAC as shown in configuration "D." Flipping the fuse holder around actually rewires the transformer primary windings as shown in configurations "A" and "D."</p> <p>Transformers are inductors. Inductors are tough to troubleshoot unless there is a catastrophic failure associated with the windings inside the inductor. An ohmmeter may be used to test for catastrophic failures, but is useless when a transformer has a problem that is not catastrophic. Therefore, a transformer can still have a problem even though it appears there is not a problem as measured with an ohmmeter. Fortunately, transformers very, very rarely fail. So chances are that any problem you may have that leads you to the transformer is most likely caused by some other component that is a load on the transformer.</p> <p>The following assumes that all crimp-on connectors are properly connected to the transformer wires, and are making contact with them, or are NOT crimped onto the insulation preventing a good electrical connection to the individual wires of the transformer.</p> <ol style="list-style-type: none"> 1. The first step to testing a transformer is to remove the secondary windings from their loads. Remove the yellow and red wire pairs from the stepping motor drive board. 2. Apply the correct power to the transformer primary depending upon the position of the fuse holder in the AC power entry module. If the line fuse blows without any loads connected to the transformer secondary windings, it is likely that it has an internal short and must be replaced. 3. Using an AC volt meter, measure the voltage across each primary winding. Do not measure with one lead of your meter to ground or the chassis, but rather measure the wire pairs with respect to each other. <ol style="list-style-type: none"> a. Measure the yellow pair of wires with a black stripe on them, by putting the red meter lead on one yellow wire, and the black meter lead on the other yellow wire. (It does not matter which meter lead goes to which transformer wire). You should measure approximately 40VAC between these two wires. If not, the transformer is faulty and must be replaced.

Table 10-1. Quick-Look Troubleshooting (continued)

Problem	Solution
<p>Testing the Transformer (continued)</p>	<p>b. Measure the red pair of wires with a black stripe on them, by putting the red meter lead on one red wire, and the black meter lead on the other red wire. (It does not matter which meter lead goes to which transformer wire). You should measure approximately 4.5VAC between these two wires. If not, the transformer is faulty and must be replaced.</p> <p>The following are tests that you can make with an ohmmeter:</p> <ol style="list-style-type: none"> 1. Each of the six windings has two wires: one lead on each end of them. Make sure you measure continuity between winding leads. If a winding is measured open, the transformer is faulty and must be replaced. 2. Next verify that none of the windings are shorted to any other winding. Using your ohmmeter, you should NOT measure continuity from one winding to any of the other five windings. If a short is measured between windings, the transformer is faulty and must be replaced.

Warranty

STREAMFEEDER® LIMITED WARRANTY

Streamfeeder, LLC (Streamfeeder) warrants this product to be free from defects in materials and workmanship, when used under recommended operating conditions, for a period of two years from the date of original retail purchase.

If you discover a defect during the warranty period, please notify the authorized Streamfeeder distributor from whom you purchased this product, who will make repairs at no charge to you. If the defect is not field-repairable, and if you return it to Streamfeeder during the warranty period, Streamfeeder will, at its sole option, repair or replace this product, at no charge to you other than shipping charges to and from the Streamfeeder facility in Minneapolis, Minnesota.

If you return this product to Streamfeeder for warranty repair or replacement, please attach to the returned product your name and your company's name, address, telephone number and fax number; a description of the problem; and a copy of the bill of sale or invoice that shows the appropriate serial number for the product. All returns must be accompanied by an authorized Streamfeeder Returned Goods Authorization (RGA) number. An authorized RGA number can be obtained from Streamfeeder Sales/Service Department.

This warranty applies only to products manufactured by Streamfeeder. This warranty does not apply if the product has been damaged by accident, abuse, misuse, neglect, improper maintenance, misapplication, or as a result of being attached to equipment not supplied by Streamfeeder; if the product has been modified without the written permission of Streamfeeder; or if the product's serial number has been removed or defaced. This warranty further does not apply to the failure of any rubber-based or consumable components, including but not limited to "O" rings, rollers, feed belts, fuses, or bulbs.

ALL IMPLIED WARRANTIES INCLUDING WITHOUT LIMITATION THE IMPLIED WARRANTY OF FITNESS FOR A PARTICULAR PURPOSE AND THE IMPLIED WARRANTY OF MERCHANTABILITY ARE HEREBY DISCLAIMED.

Streamfeeder is not responsible for special, incidental, or consequential damages resulting from any breach of warranty or under any other legal theory, including lost profits, downtime, goodwill, or damage to or replacement of equipment or property.

This warranty and the remedies set forth above are exclusive and are in lieu of all others, oral or written, express or implied. There are no warranties that extend beyond the description on the face hereof. No Streamfeeder employee, distributor, or agent is authorized to make any modification, extension, or addition to this warranty.



103 Osborne Road • Minneapolis, MN 55432-3120 USA
TEL: 763.502.0000 • FAX: 763.502.0100
E-MAIL: service@streamfeeder.com
WEB: www.streamfeeder.com

