

QuickWrap

Product Guide



Thiele
Technologies
A Barry-Wehmler Company

Streamfeeder
®

Part Number: 00900432 (Rev 2/07)

© 2007 Thiele Technologies, Inc. - Streamfeeder. All rights reserved.

No part of this publication may be reproduced, photocopied, stored on a retrieval system, or transmitted without the express written consent of Thiele Technologies, Inc. - Streamfeeder.

Thiele Technologies, Inc. - Streamfeeder
103 Osborne Road
Minneapolis, MN 55432-3120 USA

TEL: 763.502.0000
FAX: 763.502.0100
E-MAIL: service@streamfeeder.com
WEB: www.streamfeeder.com

Printed in the USA.

CONTENTS

	Safety Information	ii
	Specifications	iv
Section 1:	About the Machine	1
Section 2:	Installation.....	4
Section 3:	Setup and Operation	6
	Optional Features	11
Section 4:	Troubleshooting	16
Section 5:	Inspection and Care	18
Section 6:	Mechanical Components	20
Section 7:	Pneumatic Diagram.....	46
Section 8:	Wiring Diagrams	47

SAFETY INFORMATION

Make sure you thoroughly read this section to become familiar with all the safety issues relating to the safe operation of this product.

Please read all of the warnings that follow in this product guide in order to avoid possible injury. Although Streamfeeder has made every effort to incorporate safety features in the design of this product, there are residual risks that an installer or operator should be aware of to prevent personal injury.

Please read all of the cautions that follow to prevent damage. This product is built with the highest quality materials. However, damage can occur if not operated and cared for within design guidelines as recommended by Streamfeeder.

Message Conventions



WARNING LABELS affixed to this product signify an action or specific equipment area that can result in serious injury or death if proper precautions are not taken.



ELECTRICAL DANGER signifies an action or specific equipment area that can result in personal injury or death from an electrical hazard if proper precautions are not taken.



DANGER signifies an action or specific equipment area that can result in serious injury or death if proper precautions are not taken.



WARNING signifies an action or specific equipment area that can result in personal injury if proper precautions are not taken.



CAUTION signifies an action or specific equipment area that can result in equipment damage if proper precautions are not taken.

SAFETY INFORMATION

Message Conventions



TIP signifies information that is provided to help minimize problems in the installation or operation of the machine.



NOTE provides useful additional information that the installer or operator should be aware of in order to perform a certain task.



CHECK signifies an action that should be reviewed by the operator before proceeding.



IMPORTANT alerts the installer or operator to actions that can potentially lead to problems or equipment damage if instructions are not followed properly.



Avoid injury. Do not reach around guards.



Hazardous voltage. Contact will cause electric shock or burn. Turn off and lock out power before servicing.



Moving parts can crush and cut. Keep guards in place. Lock out power before servicing.



Pinch point. Keep hands and fingers clear.

SPECIFICATIONS

Maximum Product Size..... 9 in. W x 12.5 in. L (228 mm x 317 mm)

Minimum Material Size..... 6.5 in. W x 9.5 in. L (165 mm x 241 mm)

Min/Max Product Thickness.... .003 in to .590 in. (.076 mm - 14.9 mm)

Maximum Cycle Speed..... 50 ppm

Electrical Requirements..... 220vac, 1 phase, 60Hz, 10A

Air Requirements..... 6 CFM @ 90 PSI

FILM SPECIFICATIONS:

Film Type..... Low and high density polyethylene

Film Thickness..... .70 mil - 1.25 mil

Maximum Roll Diameter..... 11 in. (279.4 mm)

Maximum Roll Weight..... 55 lbs. (24.9 kg)

Maximum Roll Width..... 21 in. (533.4 mm)

Film Width Calculation:

Product Width X 2 + Product Thickness X 2 + 2 inches = Roll Width Required

1 About the Machine

Theory of Operation

The QuickWrap H-50 Horizontal Wrapping System™ operates with a single roll of flat film, which is automatically formed around adjustable forming plates.

When equipped with a single Streamfeeder feeder or collator base, product is automatically dispensed onto the infeed belts of the QuickWrap H-50. The product is then advanced into the forming plates with additional assistance from nip rollers.

A photoelectric sensor detects the product length. Then center and cross sealing takes place. After sealing, the product is automatically ejected from the machine.

H-50 Main Assemblies

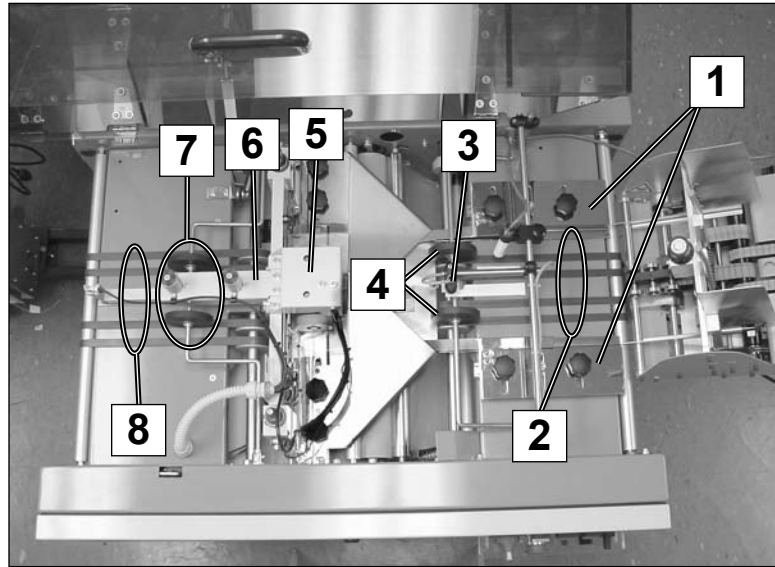

NOTE

In order to avoid timing out and not cycling when no product is present, make sure that the only LED illuminated on the FC-13 infeed sensor is the green LED.

H-50 Main Assemblies and Descriptions

Feature	Description
(1) Material Guides	Located at the infeed of the H-50, the guides capture the product prior to it entering the forming plates to prevent skewing.
(2) Infeed Belts	The belts provide the friction necessary to transport the product to the nip rollers.
(3) Infeed Sensor FC-13 <i>Refer to  above.</i>	Upon detection of the leading edge of the product as it enters the forming plates, this sensor sends a signal starting the time out function. The trailing edge is then detected and the film advance begins.
(4) Infeed Nip Rollers	The nip rollers assure product friction against the infeed belts required to advance the piece into the forming plates. Correct setting allows a light "brush" of the product as it passes beneath the nip roller.
(5) Sealing Sensor FC-12	Upon detection of the leading edge of the product, the film advance begins. Upon detection of the trailing edge, the sealing cycle begins.
(6) Sealing Assembly	Consists of integrated seal wires for performing the cross and center seal.
(7) Discharge Nip Rollers	The rollers operate similar to the infeed nip rollers. They provide proper friction against the discharge belts for positive transport of the finished product.
(8) Discharge Belts	The belts provide the friction necessary to transport the product to a finishing device or conveyor after sealing is completed.

H-50 Control Panel Components



Control Panel Feature and Descriptions

Feature	Description
(1) Main Power and Power Light:	When turned to the ON (I) position, the unit is powered up and the POWER LIGHT indicator is illuminated.
(2) Manual Cycle: <i>Refer to <input checked="" type="checkbox"/>CHECK below.</i>	Pressing this green button prepares the machine for AUTOMATIC CYCLE by heating up the sealing assembly. Pressing this button will illuminate the lamp below the switch. Pressing the red button will turn the heating process off.
(3) Automatic Cycle:	After pressing the Manual Cycle button, and the sealing assembly has come up to full temperature (usually 20 seconds) (indicated by an on/off blinking of the lamp located below the green button for Automatic Cycle), pressing this green button will start the machine for operation. The lamp will illuminate solid. Press the red button to stop.
(4) Cycle Counter:	This is a resettable counter to track finished goods quantities.
(5) Emergency Stop:	Pressing this button will immediately stop the system. Twist clockwise to release.
(6) Manual Film Advance and Seal Cycle:	This switch is used for manual operation to initiate a seal and to manually advance film. Operates when machine is in manual cycle mode. Used for a new roll of film or if a document is jammed.
(7) Long Bag/Short Bag:	Allows for quick adjust of trailing edge bag length.
(8) Sealing Time:	Setting for time duration of sealing cycle.



Before pushing the Manual Cycle button, make sure that air is applied to the machine and that the sealing bar is in the UP position to avoid damaging any parts.

Internal Controls

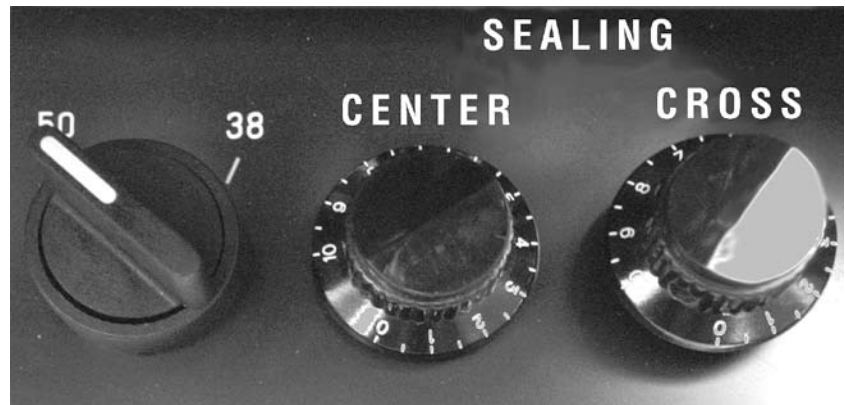

This interface board is located behind the main cover on the controls side of the machine.

CHECK

The QuickWrap H-50 operates at up to 50 packages per minute. The CYCLE selector switch should always remain on “50”. Depending upon the type of film you are using, the settings for the CENTER and CROSS seals will vary. A good starting point for the CENTER Seal is position 7 on the dial and for the CROSS Seal, position 4.

2 Installation



When performing installation, always turn the main power switch to OFF and disconnect all equipment from the electrical power source. Failure to do so can expose you to a potential startup and moving parts which can cause serious injury.

Do not attempt feeder installation while the feeder and related machinery are running. Failure to do so can expose you to moving parts which can cause serious injury. Do not wear loose clothing when operating the feeder.

Avoid turning on the feeder or making initial adjustments until all parts are secured. Failure to do so can cause damage to equipment.

The QuickWrap H-50 can be configured depending upon your particular production needs. For example:

- Stand-alone H-50 wrapper
- Integrated with one feeder (H-50-1)
- Integrated with a collator base and up to four feeders (H-50-4)

This product guide will focus on the H-50 stand-alone configuration. Basic information is included for mounting an optional single integrated feeder.



Key and latch configurations may vary.

STEP 1: Verify Machine Access

The hinged side panels of the cabinet include locking latches. To access some of the operator controls and settings the key must be used to latch and unlatch the side panels.

STEP 2: Apply Compressed Air

The QuickWrap requires an air supply capable of providing 80-90 PSI at 6 CFM.

1. Connect the air supply hose to the male air connector on the H-50. Make sure the air supply is turned on. On the H-50 air connector, slide the air valve sleeve upward to apply air to the machine.



Installation (continued)

STEP 2: Apply Compressed Air

- When air is applied, the sealer bar will travel to the upright position. The air regulator should indicate 90 PSI. If not, turn the regulator pressure adjustment knob clockwise to increase air pressure or counterclockwise to decrease air pressure.

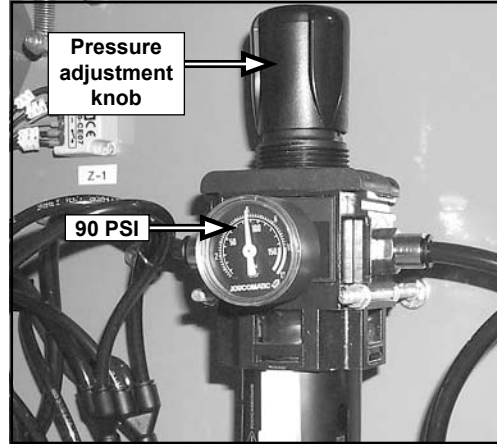

STEP 3: Connect Run Enable Jumper

Insert the run enable jumper plug (included) into the socket.



The run enable jumper **MUST** be installed.



The H-50-1 configuration uses a modified plug that also applies power to the feeder.



STEP 4: Connect Power

Connect the H-50 main power plug into a standard NEMA L6-20 power receptacle. A dedicated circuit is recommended.



If unsure about the facility's power capability, contact a qualified electrician before continuing installation.

3 H-50 Setup and Operation

STEP 1: Forming Plates and Product Guides Setting

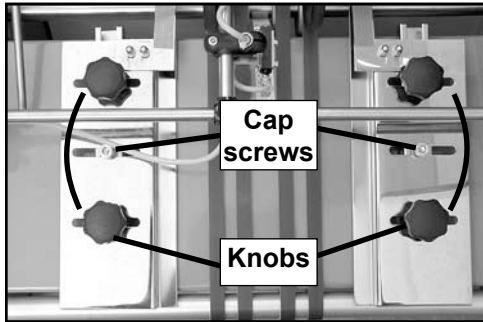

Adjust the forming plates and intake guides for proper product size by loosening the black knobs.

(To allow for removal of the forming plates, loosen the cap screws and slide the guides back toward the infeed entry area.)

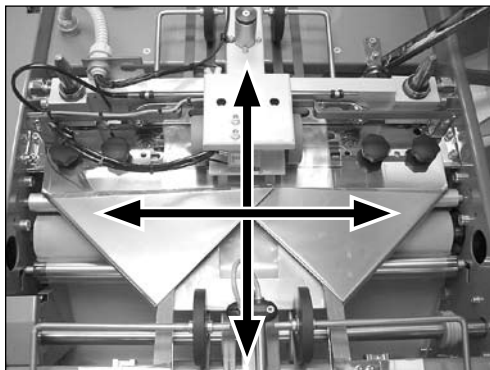

Keep the forming plates centered in the QuickWrap to produce a good center seal. Double check that the crossover point of the plates align with the middle of the machine.

Make certain the "cross-over" points of the forming plates are centered on the machine.

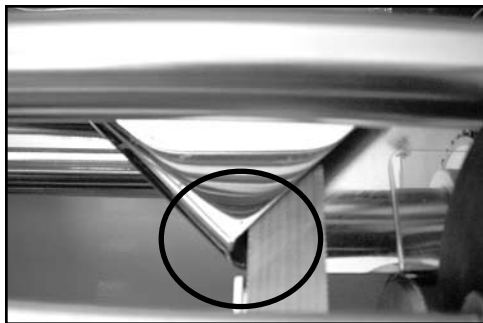

1/8 inch gap

Adjust the product guides allowing 1/8" clearance at each forming plates for film passage.

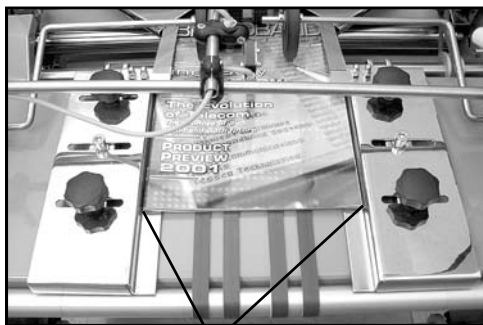

1/8 inch gap

Make sure that the intake guides and the forming plates are not too tight for the size of the product. It will be difficult to introduce the document into the forming plates and wrapping film if there is not enough product clearance.

H-50 Setup and Operation (continued)

IMPORTANT

The film must travel over the pressure roller and then under the yellow main drive roller. It must pass behind the last roller before turning up and forward towards the forming plate entrance.

CHECK

IMPORTANT

Verify that the film on the left hand plate is folded around and through the left hand plate only and not traveling under the right hand plate. Moving the film edge from the left plate into the gap between the two plates should allow the left side to correct itself.

TIP

For threading film, easy access can be attained through the rear opening below the exit end of the machine.

TIP

To simplify film loading, loosen the cap screws on the intake guides and slide the guides away from the forming plates.

STEP 2: Film Installation

1. Place the roll of film onto the two rollers as shown below. Adjust the side-to-side position using the moveable collars to keep the roll centered in the machine. Unwind the film and follow the directional drawing on the machine. Move the pressure roller away from the main drive roller to facilitate film routing. It will be necessary to apply shop air to the Quick-Wrap to feed the film under the sealing bar.

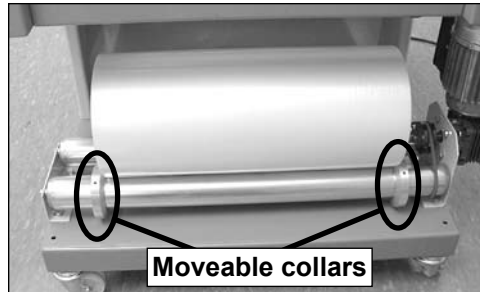

2. Position the pressure roller forward in the slots provided to move the roller away from the main drive roller.



Pressure roller away from main drive roller



Pressure roller against main drive roller

3. Load the roll of film onto the lower film feed rollers with the film unrolling from the bottom of the roll toward the inside of the machine (roll will turn clockwise as viewed from the control side).

H-50 Setup and Operation (continued)

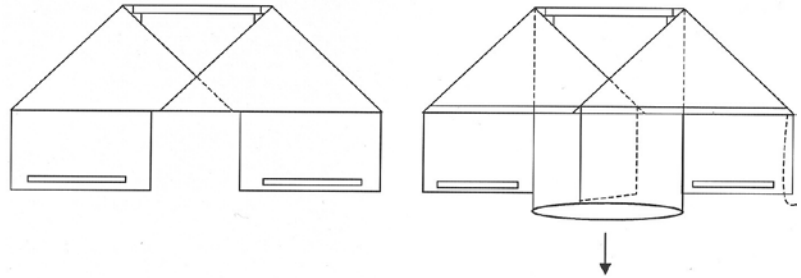

CHECK

IMPORTANT

Verify that the film on the left hand plate is folded around and through the left hand plate only and not traveling under the right hand plate. Moving the film edge from the left plate into the gap between the two plates should allow the left side to correct itself.

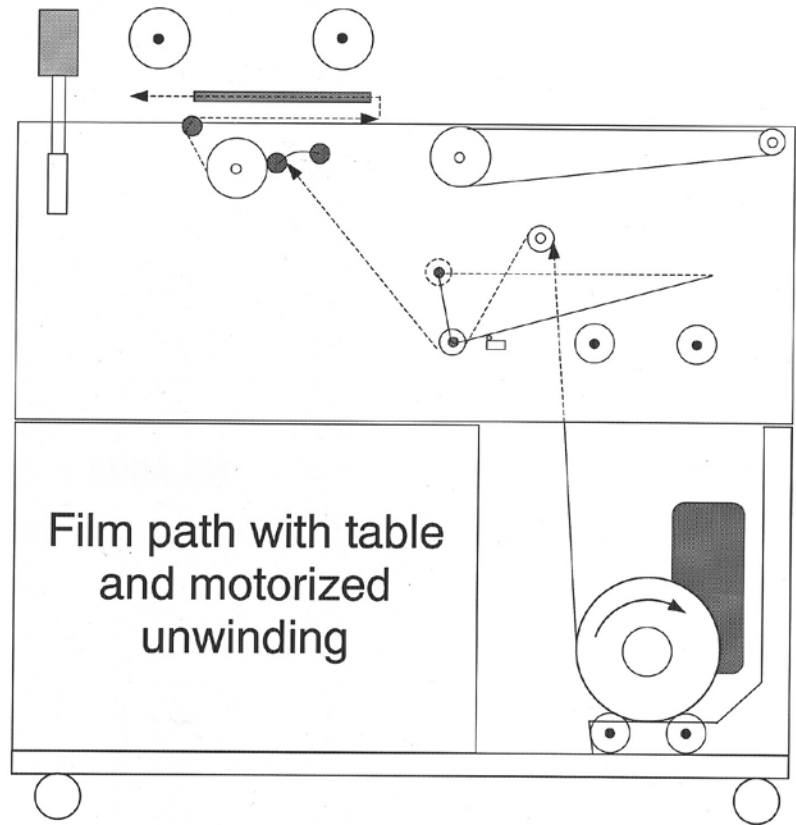

H-50 Setup and Operation (continued)

STEP 3: Bag Length Setting

The length of the bag is determined by the size of the product. It is possible to modify the proportion with the selector switch (long bag/short bag). Further “fine-tune” adjustments can be made by moving the infeed photo-cell FC-13 toward the sealing assembly to shorten the leading edge of the bag and away from the sealing assembly to lengthen the leading edge of the bag. Move in 1/4-inch increments.

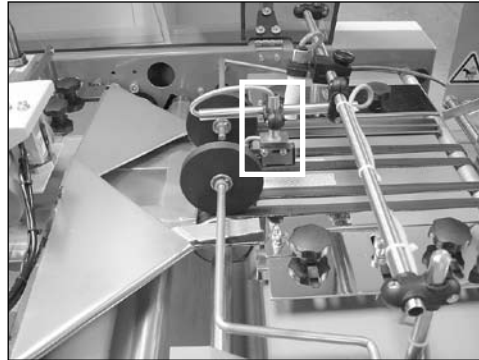

STEP 4: Sealing Time Adjustment

The sealing cycle is automatically regulated by an electric timer. The operator sets the initial sealing duration. A good initial setting would be 12 o'clock (this is a trial and error setting depending upon the film type you are using). It is important not use an excessively long sealing time; damage to the sealing wire and teflon can occur. It is always best to start low and increment up. You will need to run 10-15 packs each time you change the sealing time to ensure proper sealing.

IMPORTANT

Do not use an excessively long sealing time; damage to the sealing wire and teflon can occur.

For best production results, the packs should be flat for good center sealing.



H-50 Setup and Operation (continued)

STEP 5: Manual Operation Test



1. With power and air applied to the machine, turn the main power switch to the ON position (I) and push the MANUAL CYCLE button. The indicator light for power and for the MANUAL CYCLE lamp will illuminate.
2. Turn the MANUAL film sealing switch towards the film advance position (clockwise) in 1/2 second increments to jog the film while maintaining a firm grip and applying steady pull on film exiting the wrapper. This will cause the film to pass through the forming plates and onto the outfeed belts. Releasing the switch will allow it to return to the neutral position and stop jogging film. **Turning the MANUAL switch counter-clockwise causes the manual seal to operate and cut the film.**



CHECK

IMPORTANT

Verify that the film on the left hand plate is folded around and through the left hand plate only and not traveling under the right hand plate. Moving the film edge from the left plate into the gap between the two plates should allow the left side to correct itself.

The left hand forming plate is positioned over the right hand plate where they meet in the center. As a result, the film must be checked after installing a new roll or after a product transfer malfunction (jam) to insure that the left side of the film runs under only the left plate, not the right plate.

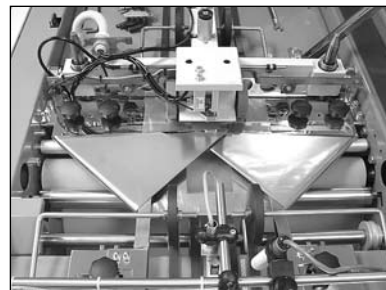

After film is threading satisfactorily, perform a manual seal cycle to clear excess film. Without product in the QuickWrap, pull the film at the output side. While maintaining tension on the film perform a manual film advance and cut cycle.

H-50 Setup and Operation (continued)

NOTE

In the event of a time-out (blockage of the H-50 infeed sensor FC-13 for 2 seconds), the system will stop and the lamp below the green Automatic Cycle button will blink. To reset, clear product from underneath sensor, press the red button under the Automatic Cycle lamp and then press the green button under Automatic Cycle to restart.

NOTE

If the safety cover is opened to remove product, the automatic and manual modes will become disabled for safety. To restart, press the Manual Cycle green button. When the Automatic Cycle lamp begins blinking, the green Automatic Cycle button can then be pressed.

OPTIONAL FEATURE: Print Registration

NOTE

The print registration option must be ordered and pre-installed at the factory.

STEP 6: Final Check and Operation Start

The machine is now ready to run. Make sure that the side guides on the infeed are set correctly and there is proper clearance between them, the product, and the forming plates.

With the MANUAL CYCLE button illuminated and the sealing assembly at the proper temperature (indicated by a blinking light under the automatic cycle button), press the AUTOMATIC CYCLE button to start the machine. The infeed belts will begin turning.

The QuickWrap H-50 is capable of running films that include printing. The printing must not block the FC-12 photocell reading area. The center and both edges of the film must be transparent so that the beam of the photocell can pass through all three layers of film. In order to ensure proper operation of photocell FC-12, a 5/8 inch (16mm) window should be maintained in the center of the film and across the center seal of the film. If a print window can not be maintained in the center of the film, or the print needs to be registered, the Print Registration Option is required for proper operation.

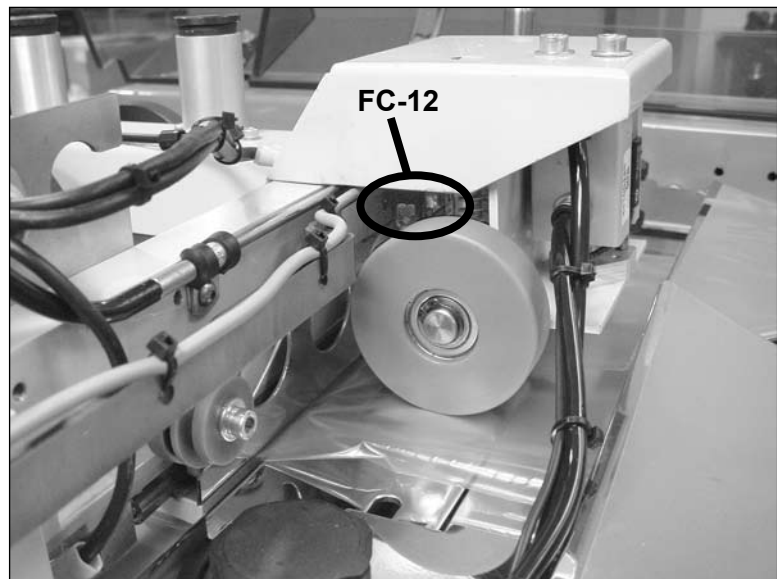

H-50 Setup and Operation (continued)

OPTIONAL FEATURE: Print Registration (continued)

The Print Registration Option includes the following modifications to the H-50:

- Photocell FC-14 is used for running non-registered pre-printed film.
- Photocell FC-15 is used to read spot marks for film registration.

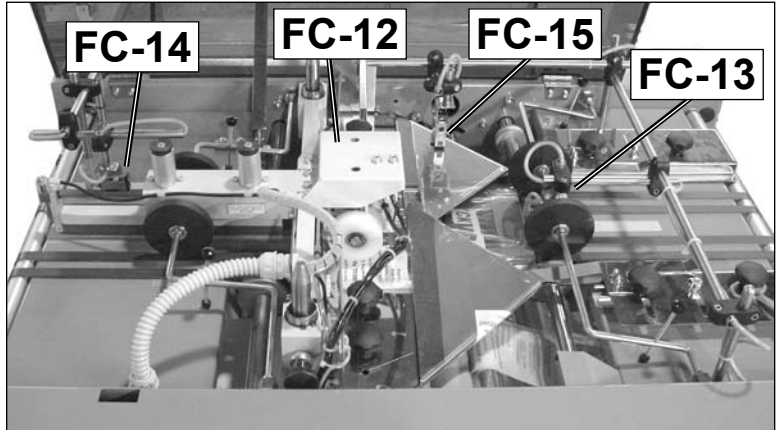

- Selector switch S-11 is used to switch from clear to pre-printed films.
- Selector switch S-17 enables photocell FC-15 to read either clear marks on dark background or dark marks on clear background.

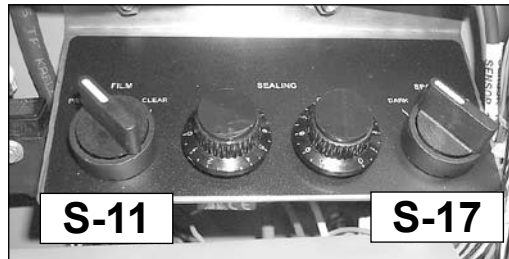

- Selector switch S-16 enables the spot reading function to be turned ON/OFF (With/Without).

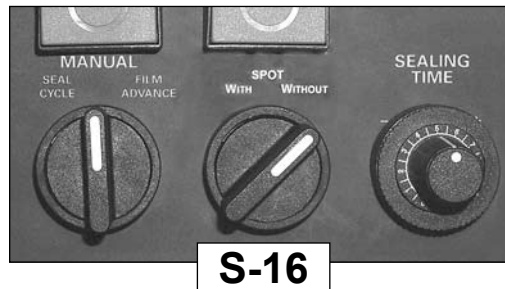

H-50 Setup and Operation (continued)

OPTIONAL FEATURE: Print Registration (continued)



*When photocell FC-14 detects no product, both the green and amber LEDs are illuminated.
When photocell FC-14 detects product, the amber LED is off.*

Running Clear Film

To run clear films (films with a clear reading window in the center of the film), set switch S-11 to the "Clear" position and switch S-16 to the "Without" position. In this position, photocell FC-12 triggers the feed rollers and photocell FC-14 will trigger the sealing bar to close. The bag length can be adjusted by moving photocell FC-14 towards the sealing bar for a shorter bag, and away from the forming plates for a longer bag.

Running Opaque (pre-printed) Films Without Spot Registration

To run opaque non-registered films (without a clear reading window in the center of the film), set switch S-11 to the "Printed" position and switch S-16 to the "Without" position. In this position, photocell FC-13 triggers the feed rollers and photocell FC-14 will trigger the sealing bar to close. The bag length can be adjusted by moving photocell FC-14 towards the sealing bar for a shorter bag, and away from the forming plates for a longer bag; FC-14 must be set at least to the length of the product being run.

Running Opaque (pre-printed) Films With Spot Registration

To run opaque registered films, set switch S-11 to the "Printed" position and switch S-16 to the "With" position. In this position, photocell FC-15 is activated so that if it detects a registration mark it will close the seal bar. Set switch S-17 to "Clear" to detect a clear mark on dark background, or "Dark" to detect a dark mark on clear background. The printing is centered on the product by moving photocell FC-15 across the forming plates. Bag length is decreased by moving photocell FC-13 toward the forming plates, and away from the forming plates for a longer bag.

H-50 Setup and Operation (continued)

OPTIONAL FEATURE: V-750 Feeder (H-50-1)



Detailed information regarding the V-750, V-755, or the collator base can be found in their corresponding product guides.

The QuickWrap H-50 can be configured depending upon your particular production needs with up to four feeders. The following is basic information for mounting an optional single integrated feeder.

STEP 1: Mounting the Feeder

Attach the feeder mounting bracket to the H-50 with the hardware provided. Place the feeder on the bracket and secure it with the four mounting knobs.

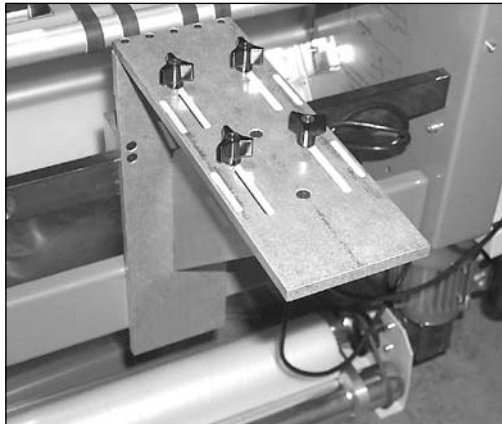

STEP 2: Connect Power

Connect the power cord into the feeder and the other end into the H-50 interface connector (this plug also allows the H-50 to be operated).



H-50 Setup and Operation (continued)

OPTIONAL FEATURE: V-750 Feeder (H-50-1) (continued)

STEP 3: Sheet Detect Photo Sensor

Connect the sheet detect photo sensor to the input connector on the feeder.

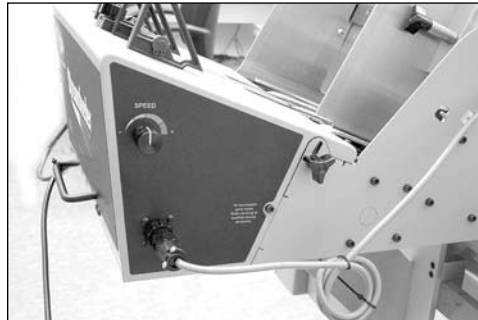

Secure the sensor to the mounting bracket located on the infeed cross shaft of the H-50.



NOTE

When properly positioned, only the green LED will be on. When a piece passes beneath the sensor the amber LED will then illuminate. After the piece passes, the amber LED goes out.

Align the sensor with the reflective tape to ensure consistent signal.



4 Troubleshooting

The following provides quick solutions to the more common day-to-day problems you may encounter.

Problem	Cause	Solution
Product too far onto the H-50 infeed belts	1. Photo sensor “staging” leading edge of product too far onto the H-50 infeed belts.	Review photo sensor adjustment procedure- -adjust sensor back toward the feeder or reduce feeder speed.
	1. Photo sensor “staging” leading edge of product not far enough onto the H-50 infeed belts.	Review photo sensor adjustment procedure- -adjust sensor away from the feeder or increase feeder speed.
H-50 won't cycle	1. Infeed sensor FC-13 in a constantly blocked state	Make sure that only the green LED is illuminated when no product is present. Make sure the reflective tape is in place. Check sensor alignment.
Pack enters forming plate but jams prior to reaching photocell seal trigger	1. Infeed guides set too narrow.	Adjust as needed.
	2. Infeed nip rollers set too low.	Adjust as needed.
Product travels through forming plates and reaches photocell and machine automatically shuts down	1. Lack of air pressure.	Check air pressure regulator on the back panel of the H-50 and verify a reading of 90 psi on air gauge. Adjust as needed.
	2. Sealing bar sensors out of adjustment.	Consult a qualified technician.
Film overlap and/or longitudinal seal not centered on package	1. Film roll offset on film feed unit.	Adjust as needed.
	2. Forming plates are offset from machine center.	Adjust as needed.

Problem	Cause	Solution
Excessive fuming from cut wire and/or weak seals at package ends	1. Film sticking to cut wire.	Check the condition of teflon tape around/ underneath sealing wire. Replace as required. If problem persists, consult a qualified technician.
Hairlike fragments are noted on cross seal when using high density films	1. Loss of psi during sealing cycle. 2. Sealing time too long. 3. Teflon tape on silicon blocks deteriorated.	Adjust psi (not to exceed 90 psi). Gradually decrease sealing time until satisfactory sealing is achieved. Check and replace tape as needed.
Wrinkled or loose film around the forming plates	1. Forming plates not centered on machine. 2. Film roll not centered on machine.	Adjust as needed. Adjust as needed.

5 Inspection and Care

Please read this Section to learn how to:

- Visually inspect your machine to detect part problems which may require adjustment or replacement.
- Periodically care for your machine to prevent any operational problems.

Weekly Inspections

- Teflon tape: check for wear and deterioration. Replace as required.

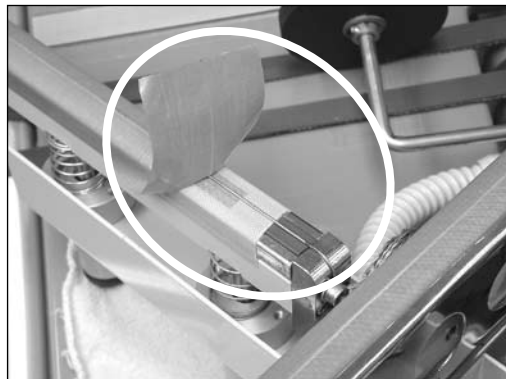

Visual Inspection: H-50

IMPORTANT

All H-50 adjustments should only be performed by a qualified technician.

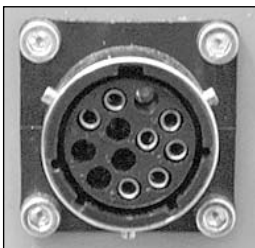

- Sealing wires: check for tightness and wear. Adjust/replace as required. When replacing, do not overtighten the set screws that secure the wire. The complete sealing frame may be easily removed if needed. Replacement length of the sealing wire for both cross and center seal is 350 mm.
- Air Valves: Air valves are preset at the factory and are not adjustable.
- Chains: Inspect for wear and adjustment. Properly adjusted chains should have 1/4 to 1/2 inch of play.
- Rollers and Drive Wheels: Inspect for wear.
- Clutches: There are two clutches on the H-50; one for the film drive and one for the belt transport drive. Proper gap setting is 0.2 mm.
- Brakes: There are two brakes on the H-50; one for the film drive and one for the belt transport drive. Proper gap setting is 0.2 mm.
- Interface Connection:
Pins F and H function as a jumper for the machine enable.
Pins A and B provide 220V for feeder operation.
Pin M is ground.

6 Mechanical Components

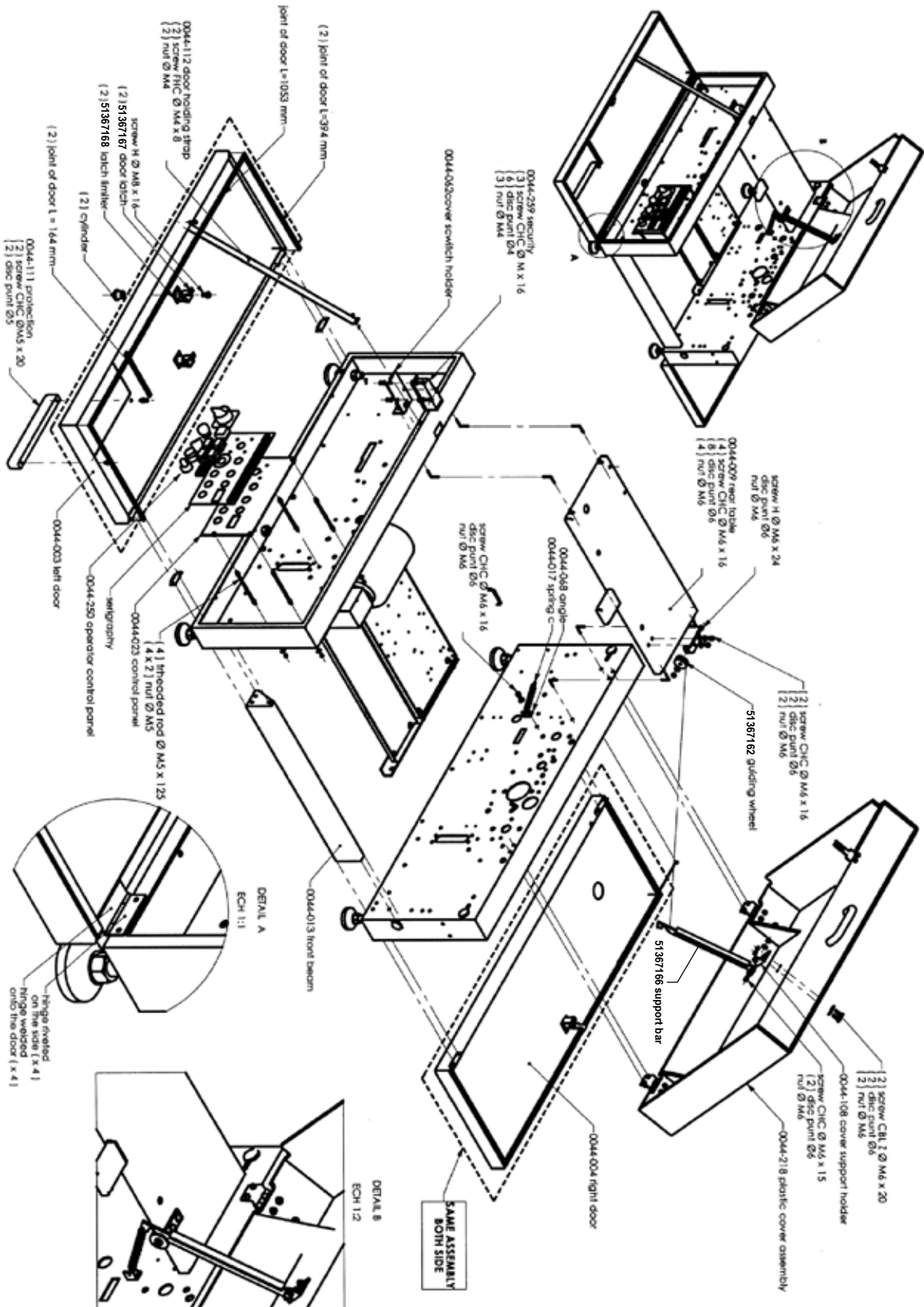

PLASTIC COVER, RIGHT AND LEFT DOOR ASSEMBLY

SUB FRAME

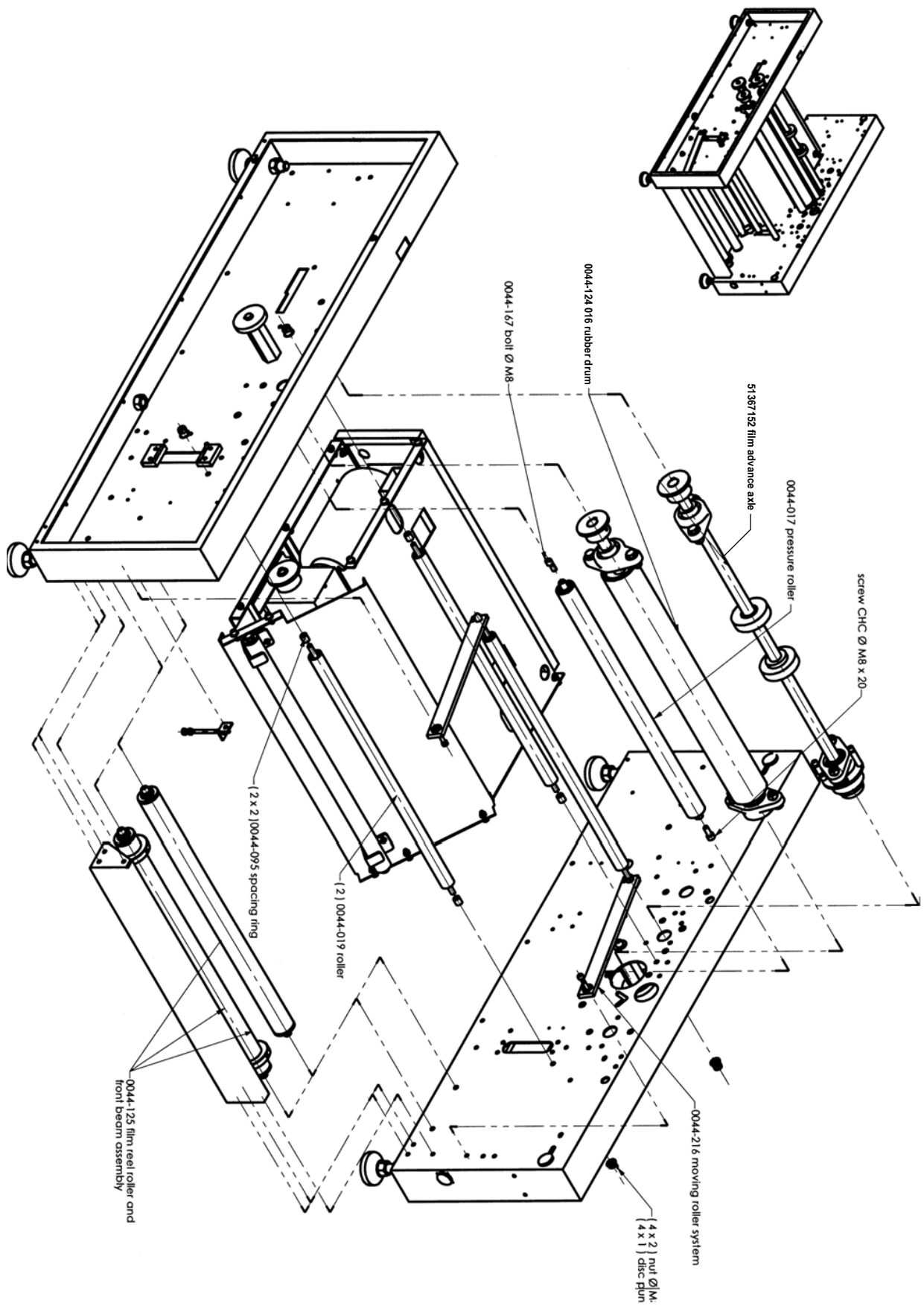

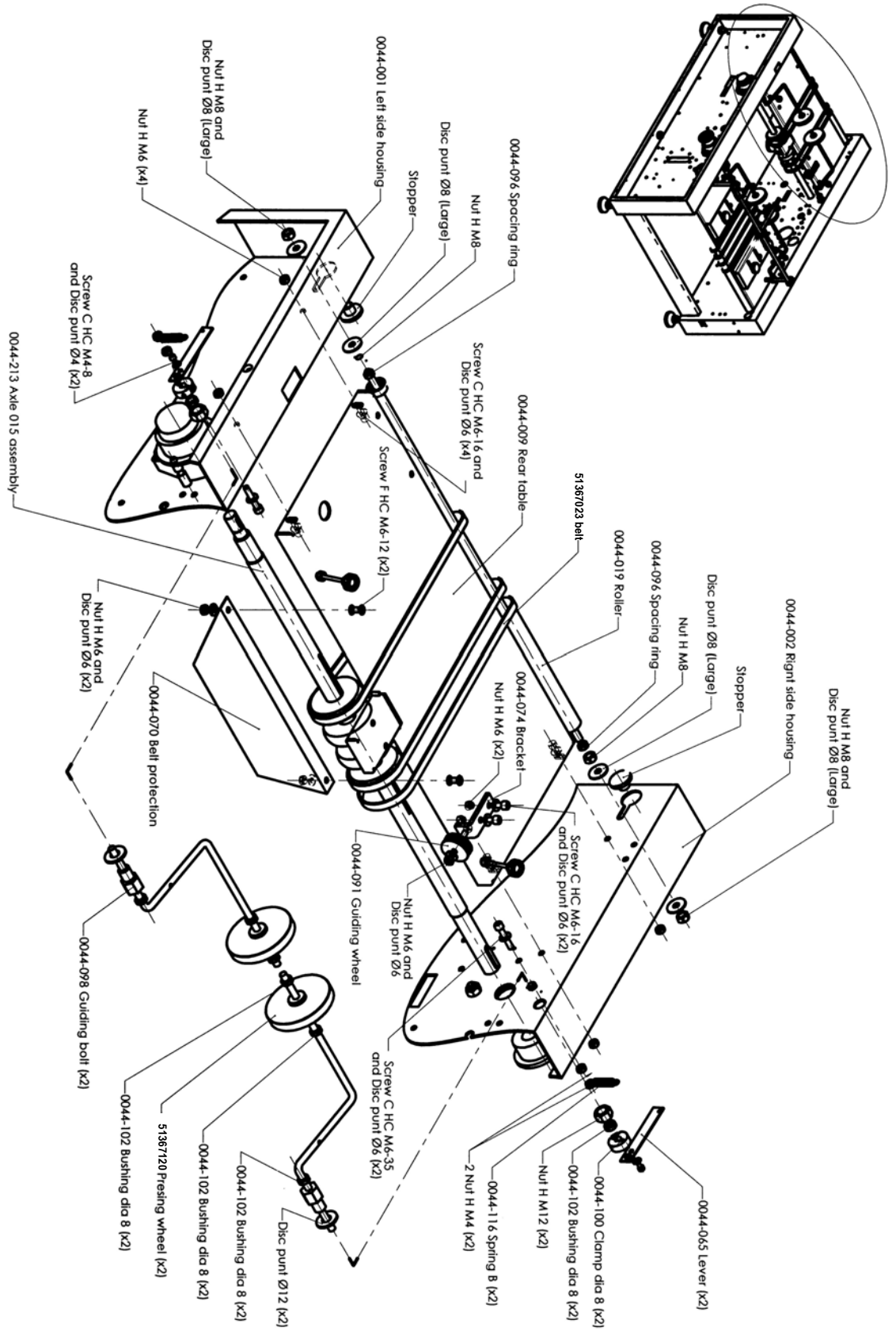

DOCUMENT EJECTION SYSTEM

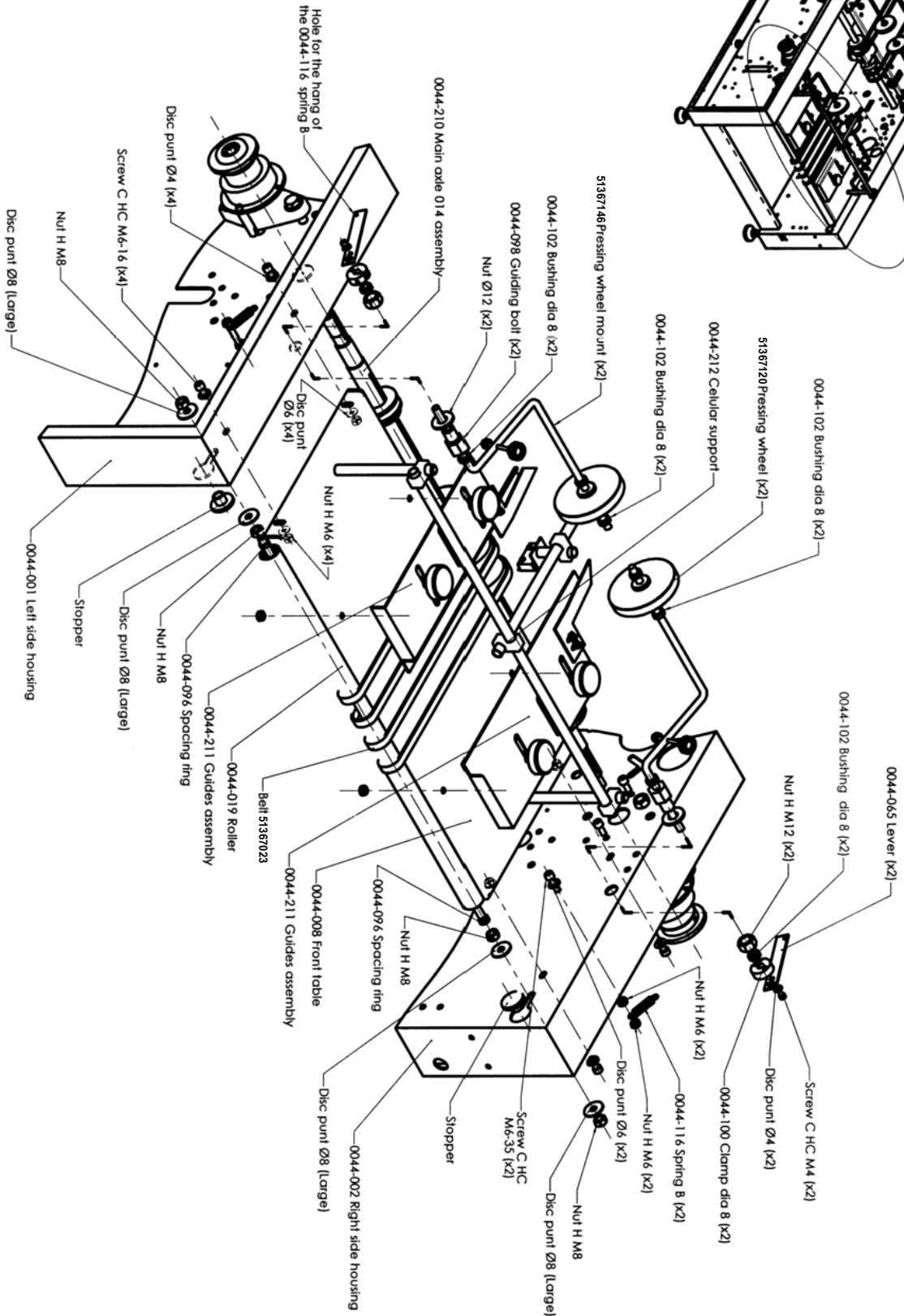
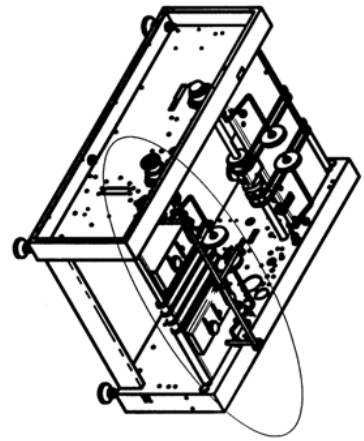

DOCUMENT ADMISSION SYSTEM

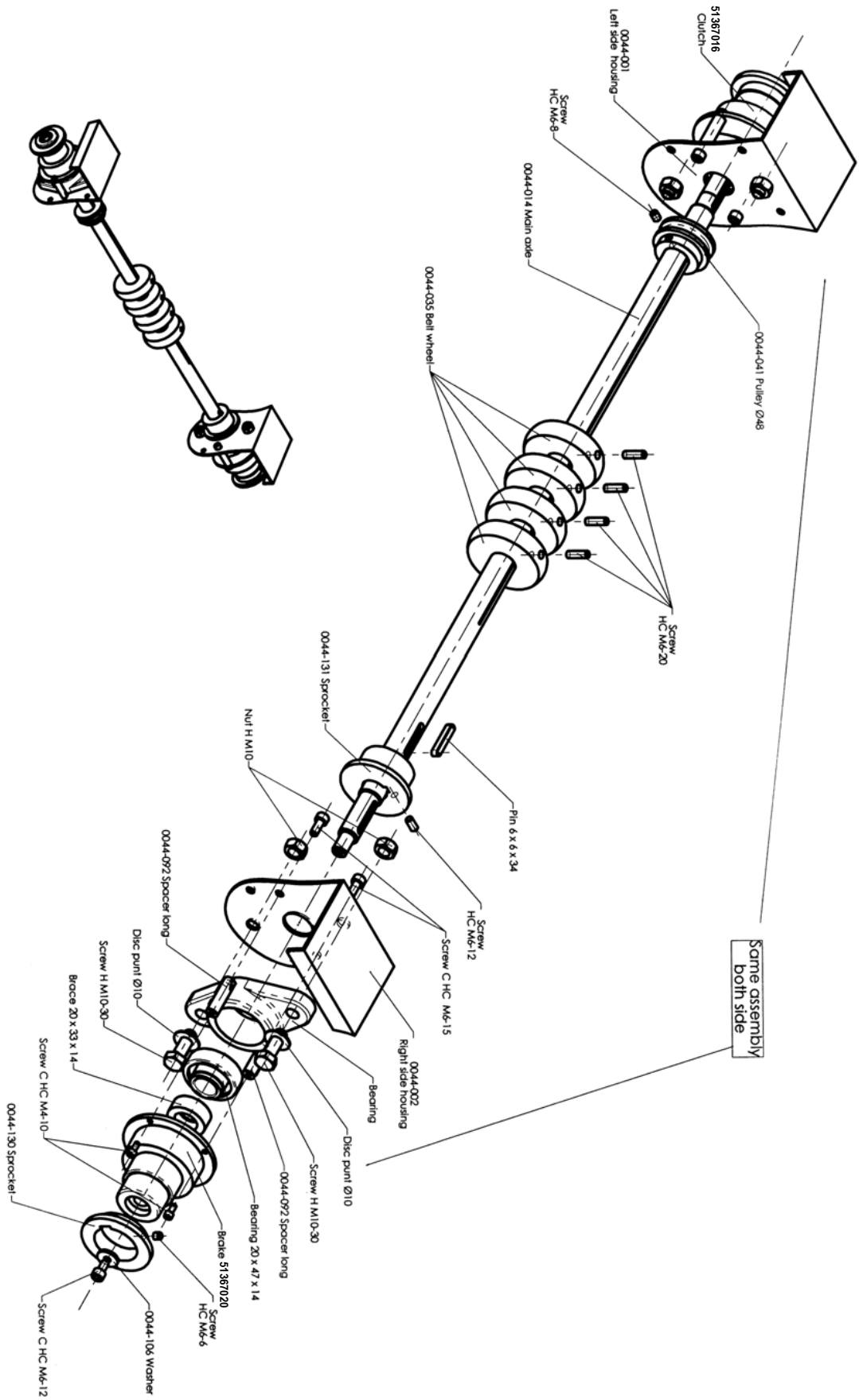

MAIN AXLE 014 ASSEMBLY

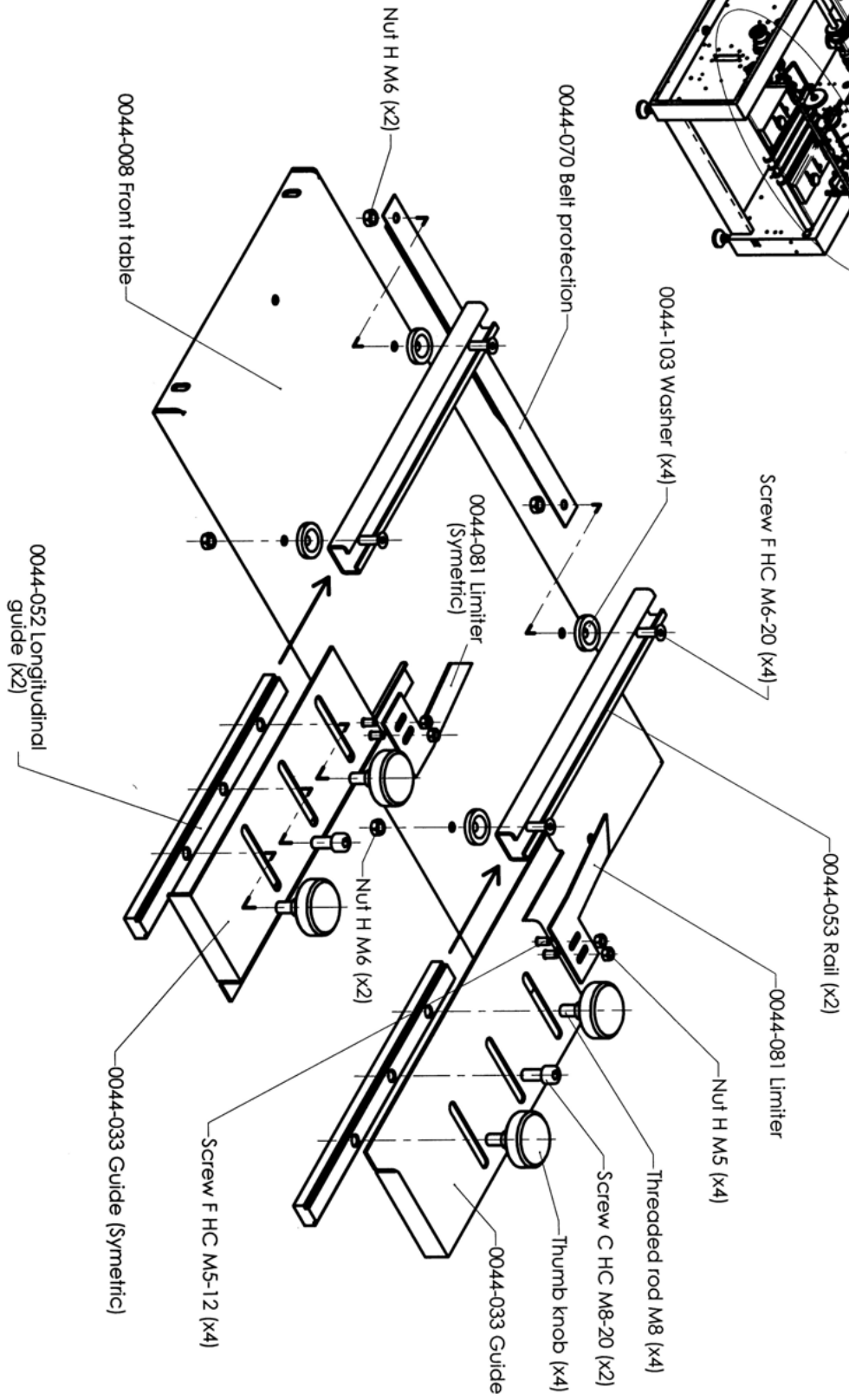
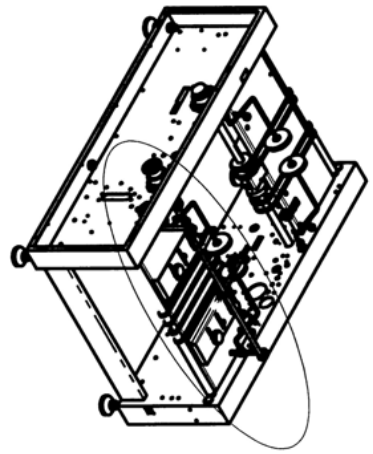

GUIDES ASSEMBLY

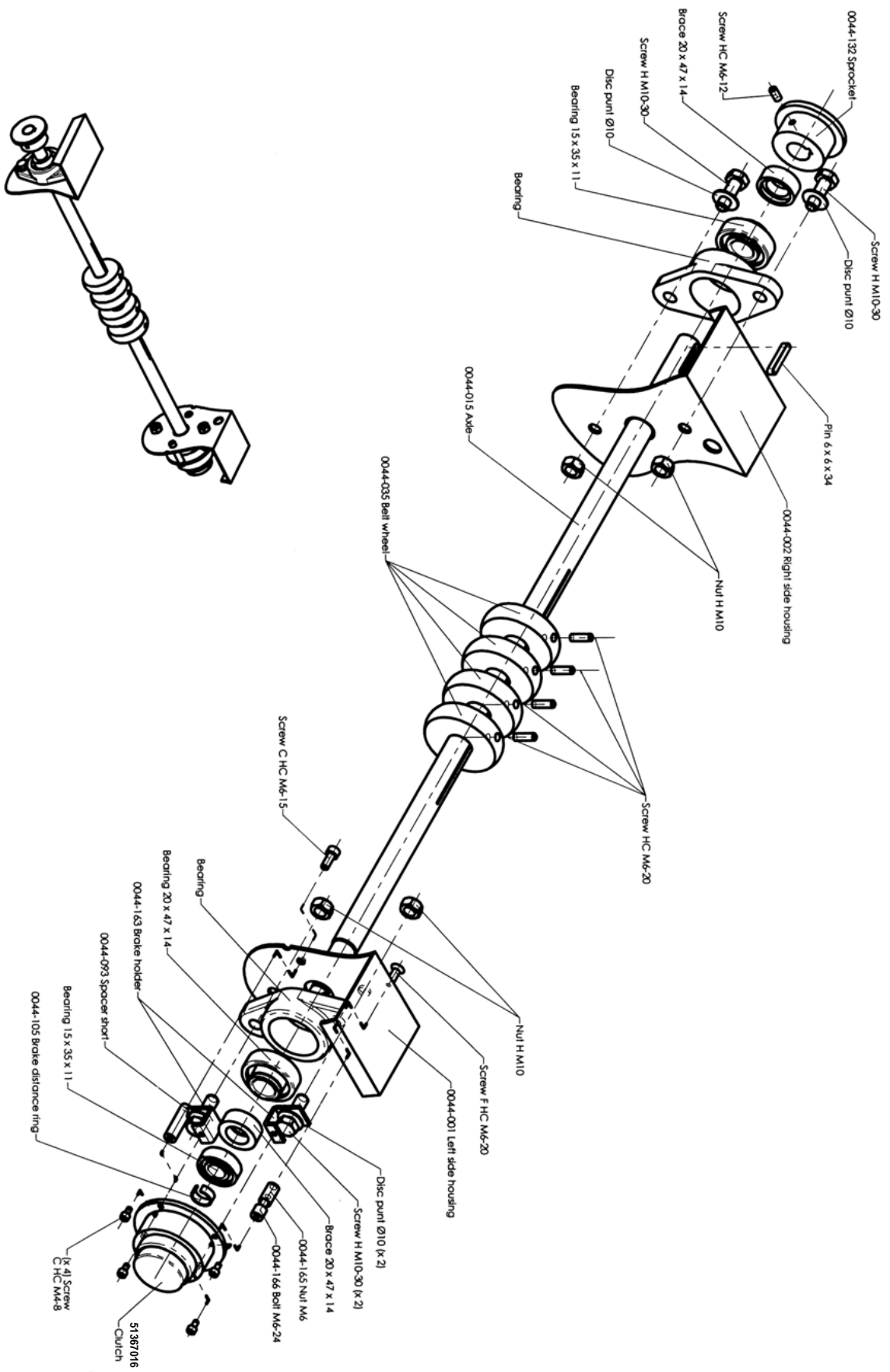

AXLE 015 ASSEMBLY

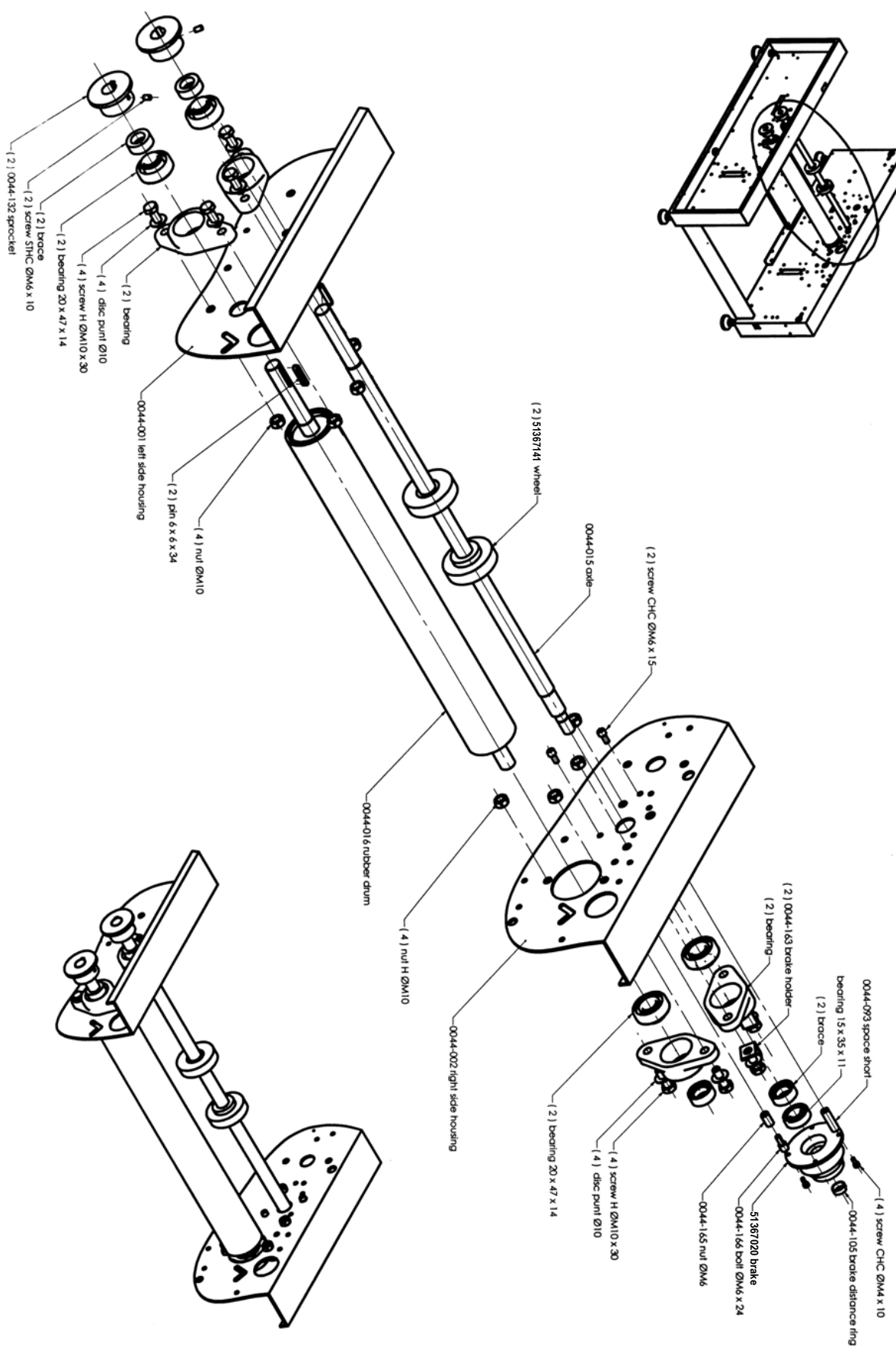
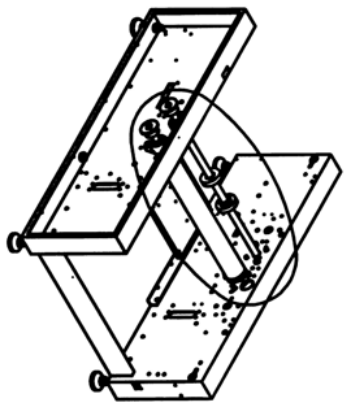

RUBBER DRUM AND AXLE ASSEMBLY

MOVING ROLLER SYSTEM

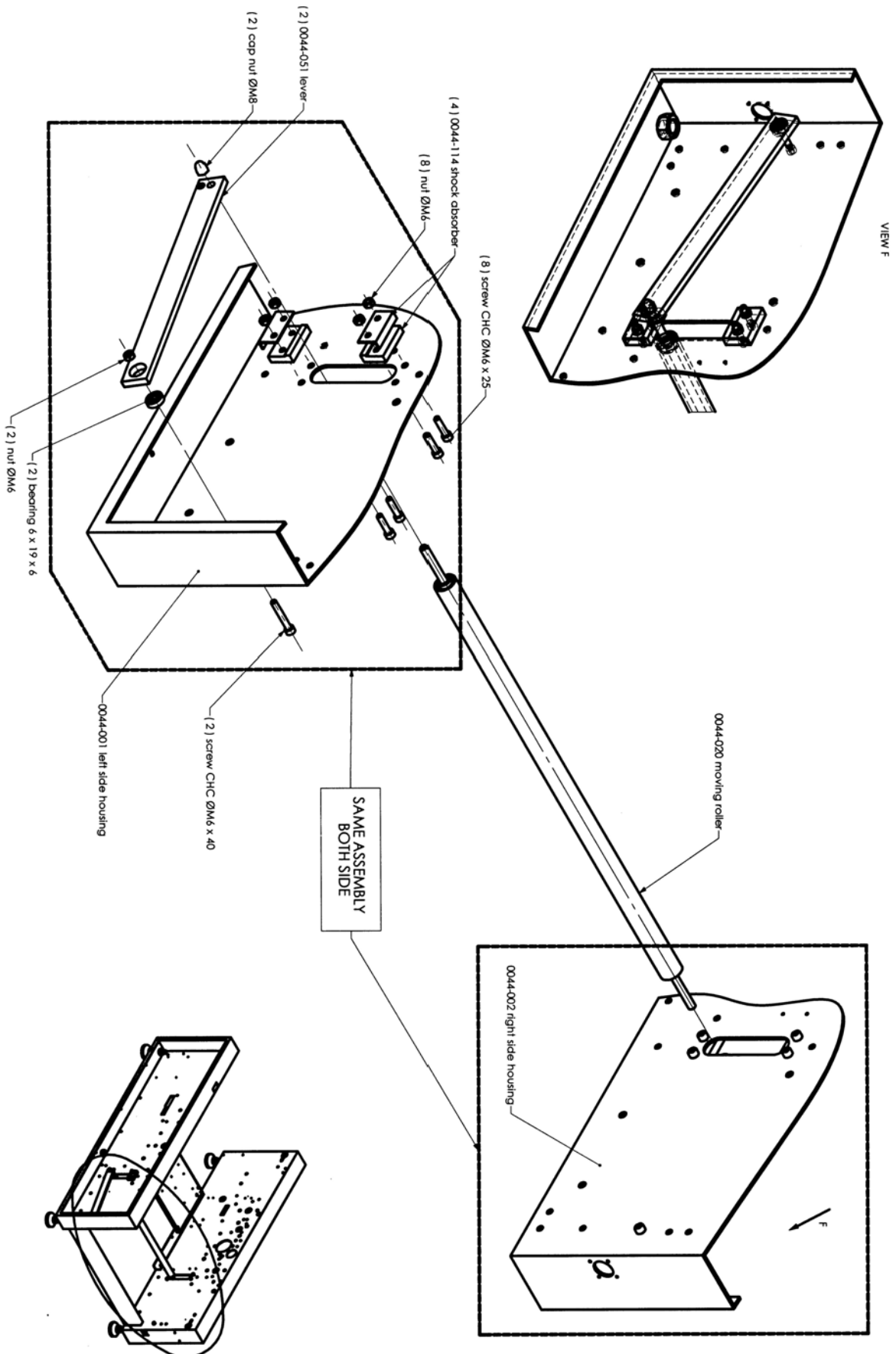

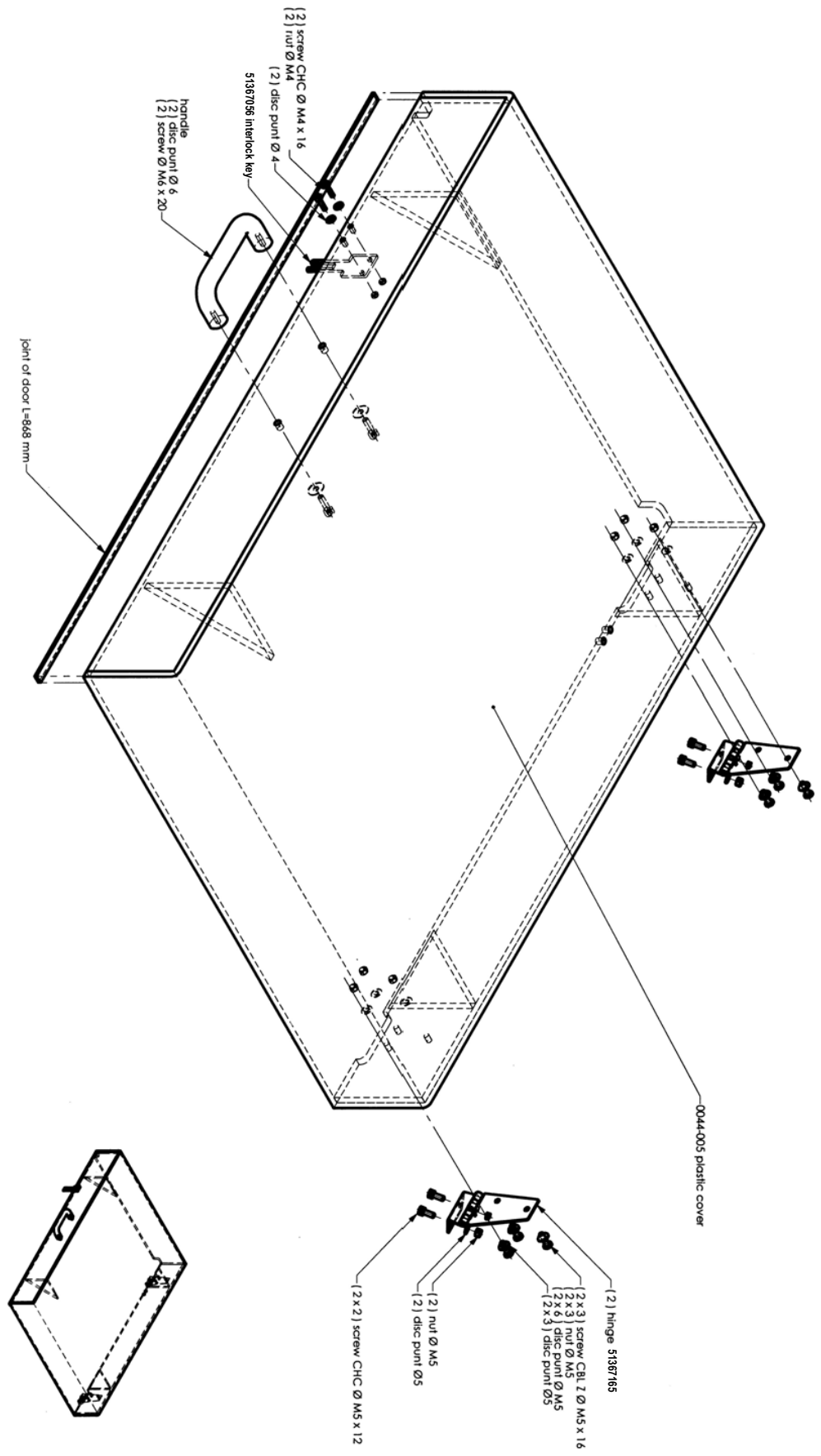

PLASTIC COVER ASSEMBLY

CLUTCH ASSEMBLY

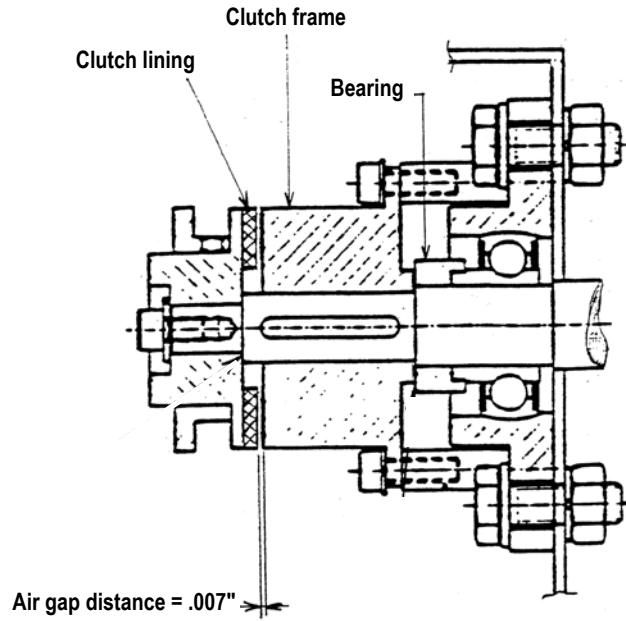

BRAKE ASSEMBLY - 51367020

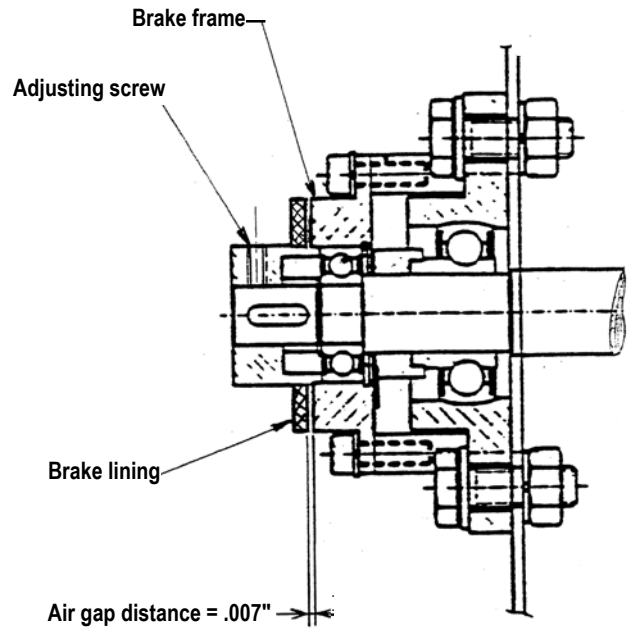
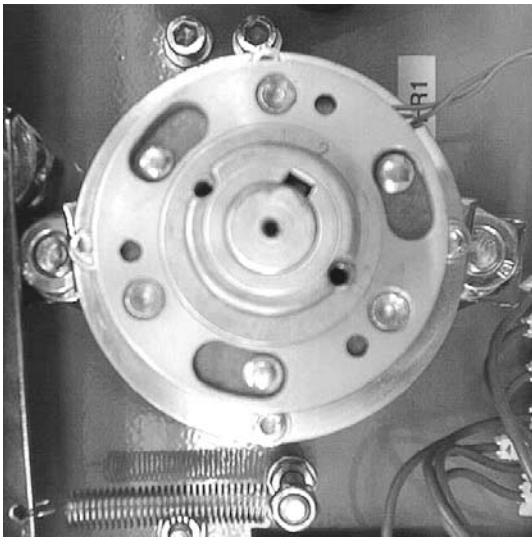

CENTER SEAL ASSEMBLY

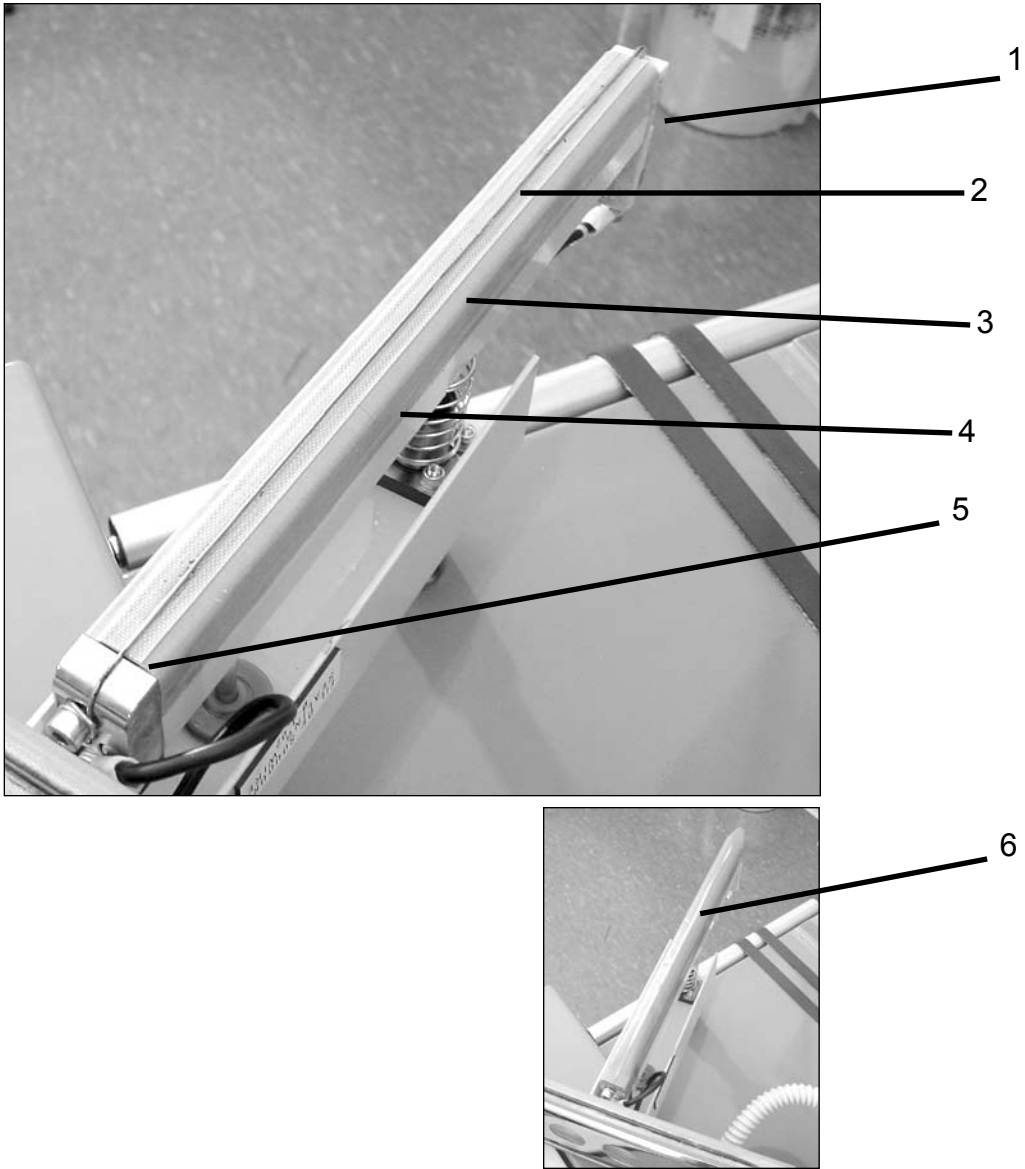

- (1) 51367019 Center Seal Wire Mount (N/S)
- (2) 13671102 1.02 Sealing Wire
- (3) 51367105 Teflon Tape, 10mm x 36 Yard Roll
- (4) 51367104 Teflon Tape, 51mm x 36 Yard Roll
- (5) 13671108 Silicon Insert, Sealing Bar Protective, 10 x 10 (beneath teflon tapes)
- (6) 51367107 Teflon Tape, 50mm x 36 Yard Roll

CROSS SEAL ASSEMBLY

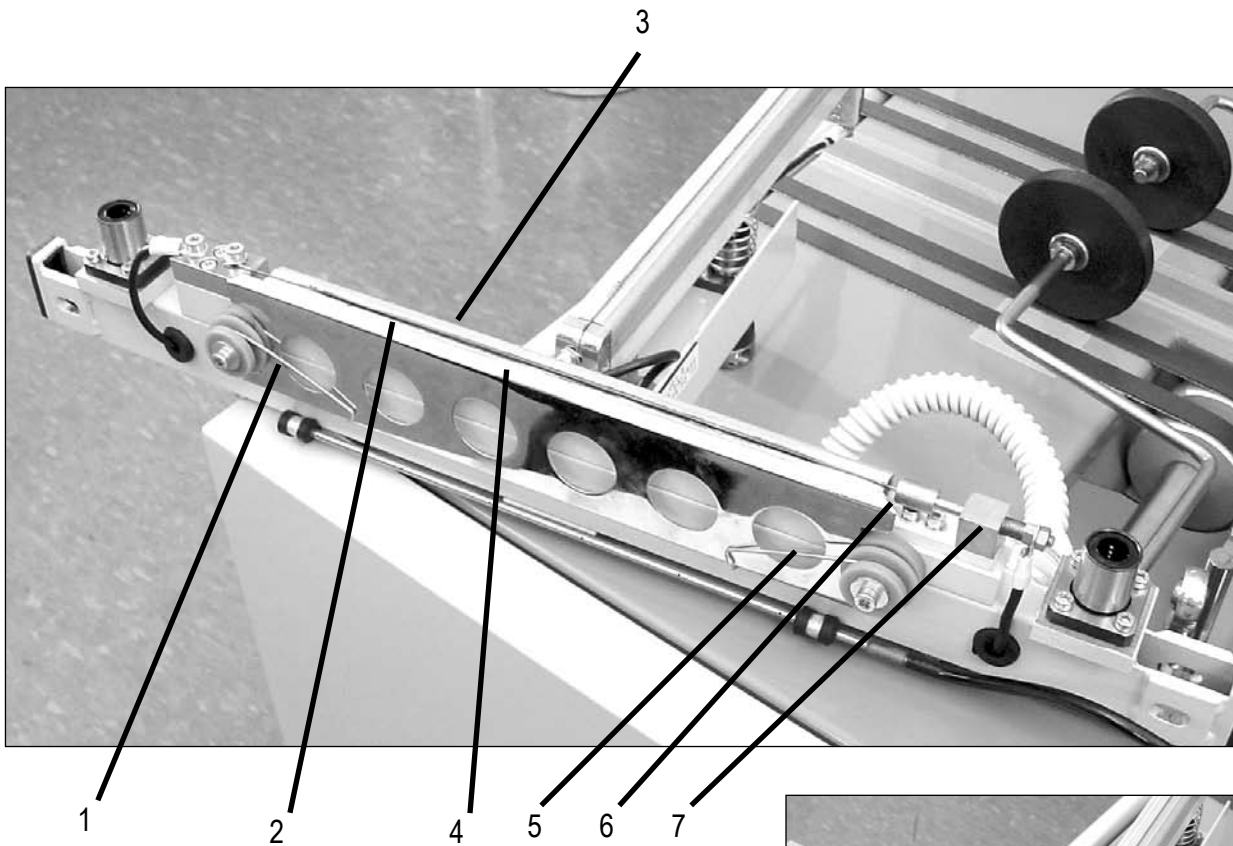

- (1) 51367031 Sealing Plate Spring, Right
- (2) 13671102 1.02 Sealing Wire
- (3) 51367104 Teflon Tape, 51mm x 36 Yard Roll
- (4) 51367105 Teflon Tape, 10mm x 36 Yard Roll
- (5) 51367030 Sealing Plate Spring, Left
- (6) 51367018 Cross Seal Wire Brass Mount
- (7) 13671108 Silicon Insert, Sealing Bar Protective, 10 x 10 (beneath teflon tape)
- (8) 51367107 Teflon Tape, 50mm x 36 Yard Roll

INFEED - TAPES

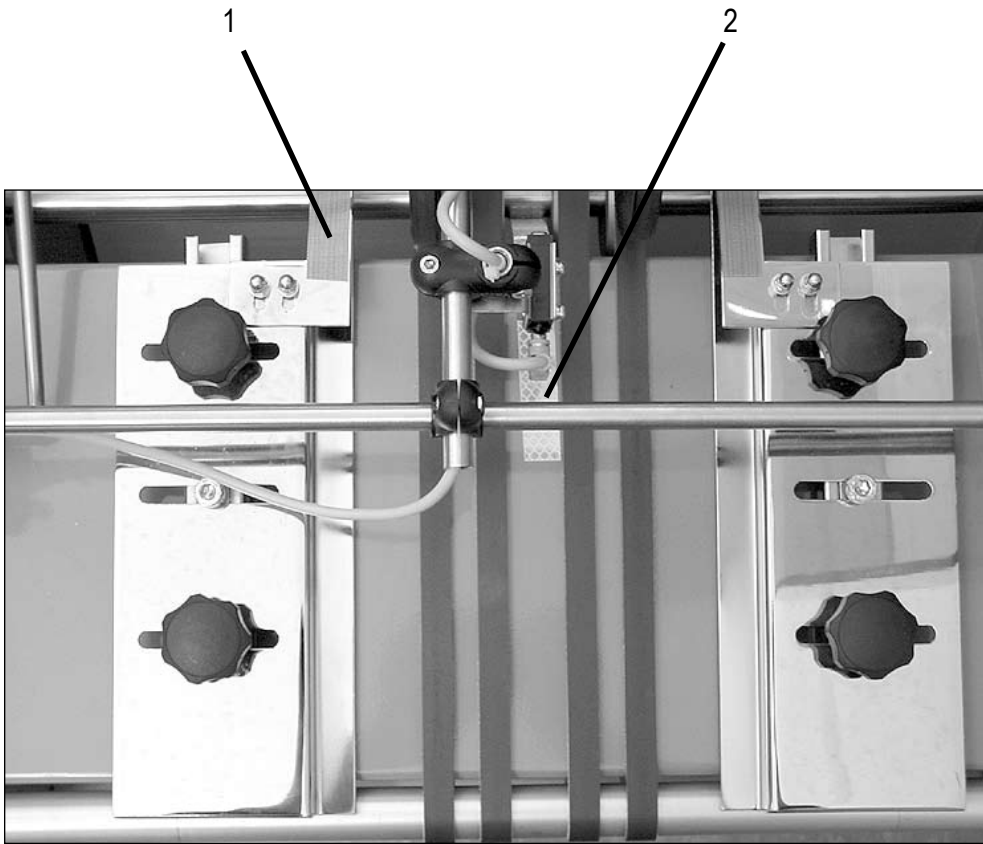

- (1) 51367106 Teflon Tape, 19mm x 36 Yard Roll
(2) 53500150 2 x 3 Retroreflective Tape

UTILITIES (not pictured)

- 44813006..... Air fitting
51367075..... Twist Lock Plug, 220V, 20 amp

DECK TOP: EXIT END

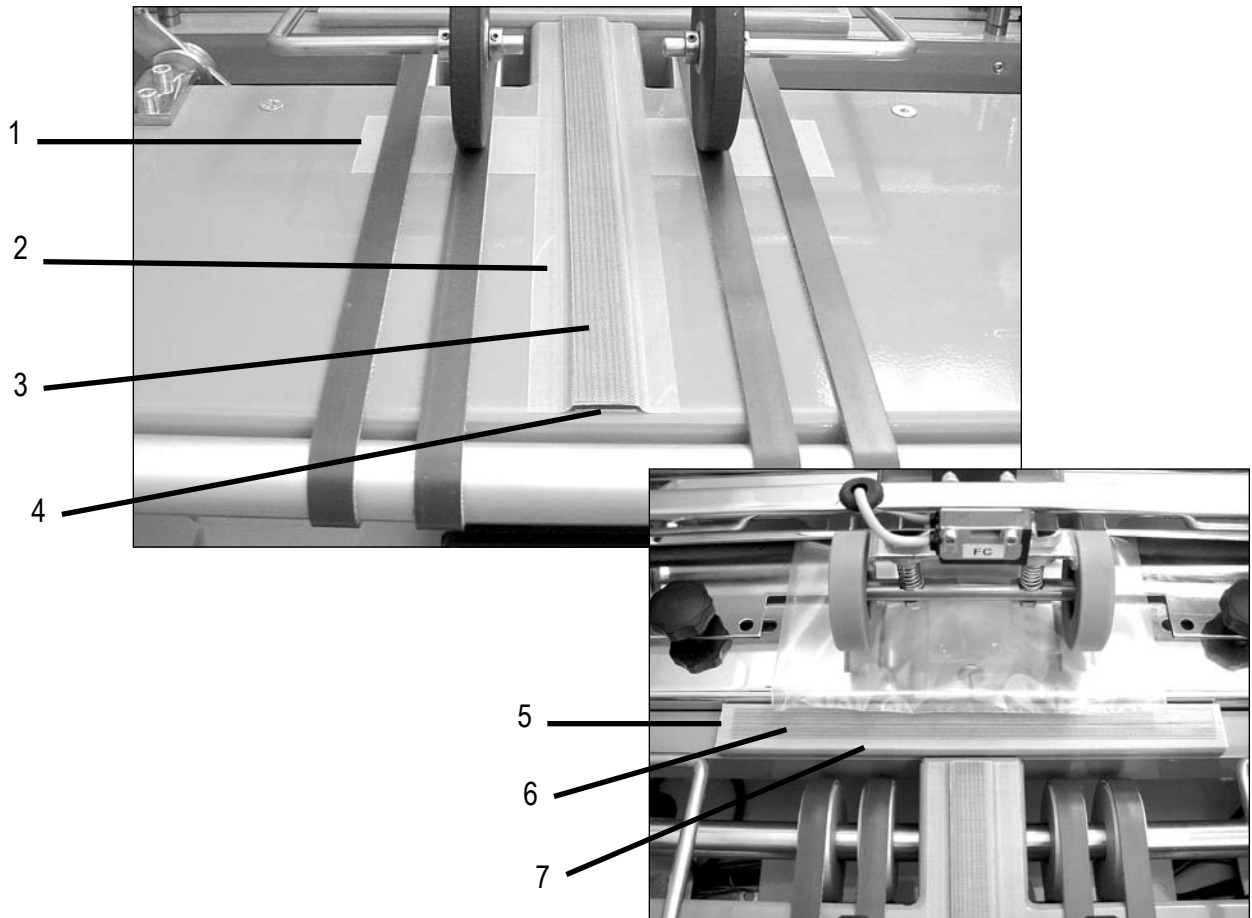

- (1) 51367104 Teflon Tape, 51mm x 36 Yard Roll
- (2) 51367107 Teflon Tape, 50mm x 36 Yard Roll
- (3) 51367106 Teflon Tape, 19mm x 36 Yard Roll
- (4) 13671104 Silicon Insert, Center Seal Deck, 2 x 20-315
- (5) 13671105 Silicon Insert, Cross Seal Deck, 8 x 30-280
- (6) 51367106 Teflon Tape, 19mm x 36 Yard Roll
- (7) 51367107 Teflon Tape, 50mm x 36 Yard Roll

CIRCUIT BREAKER ASSEMBLY

1P C3 06370 CIRCUIT BREAKER
REF: 0110614

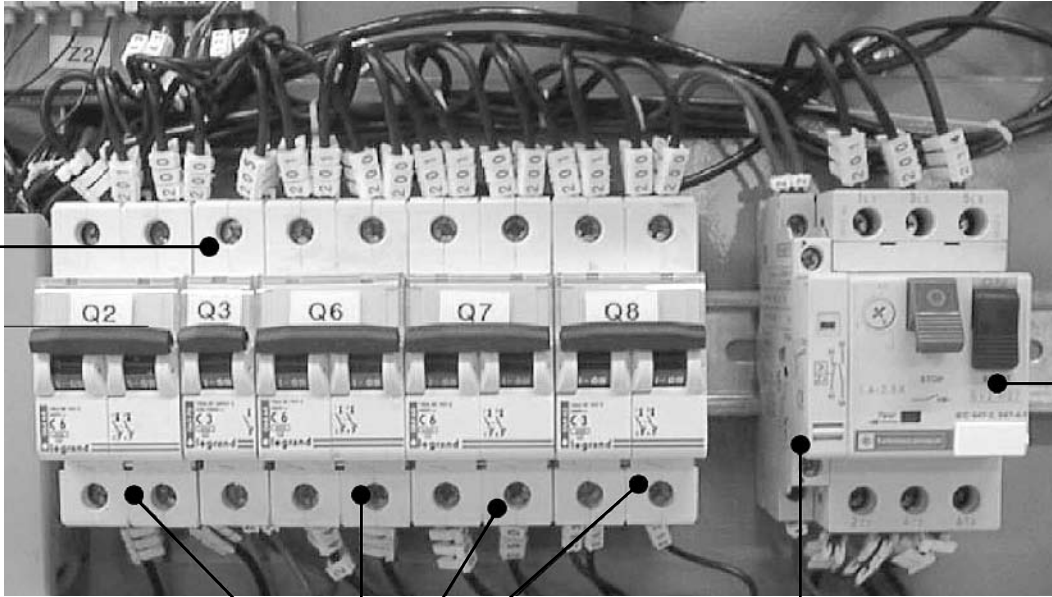

2P C6 06464 CIRCUIT BREAKER
REF: 0110611

CONTACT
REF: 0110611

2P C6 06464
CIRCUIT BREAKER
REF: 0110611

REGULATOR ASSEMBLY - 51367017

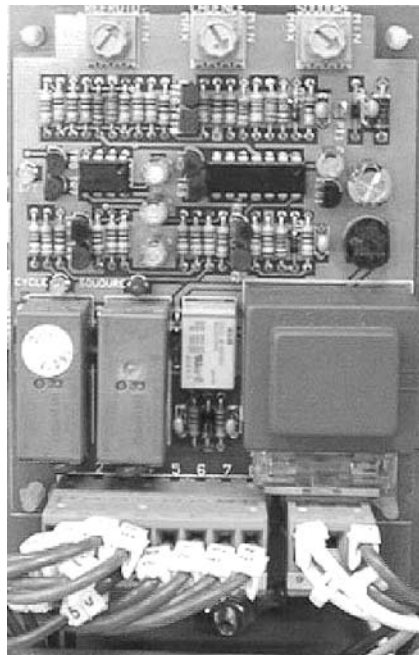

RELAY ASSEMBLY

RELAY 51367098

RELAY 51367021

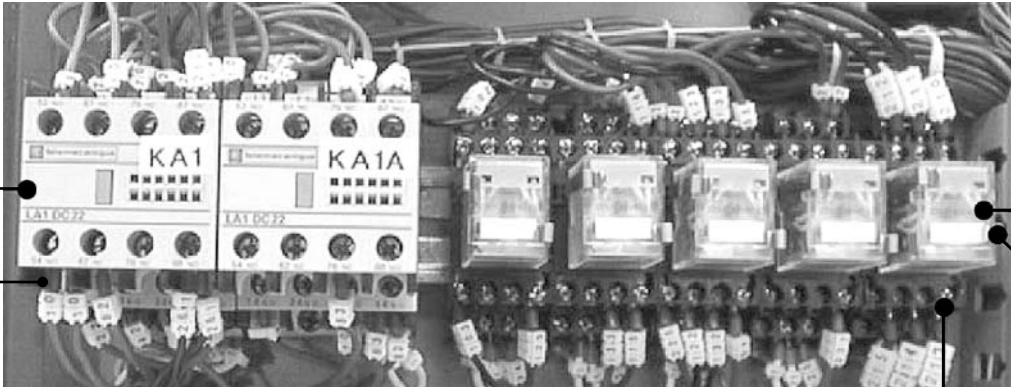

RELAY BLOCK
51367099

RELAY BLOCK
REF: 0110615

CLIP
REF: 0110615

PLC ASSEMBLY

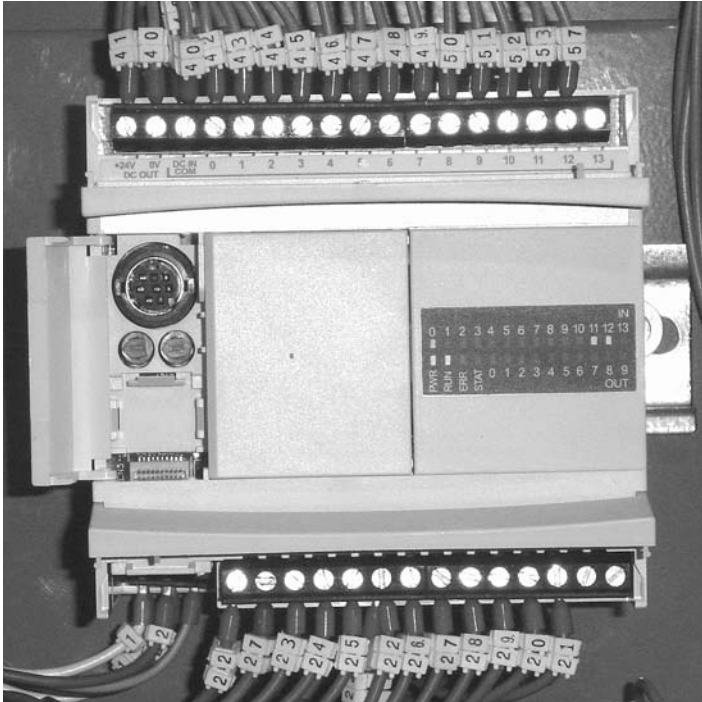

RECTIFIER - 51367015

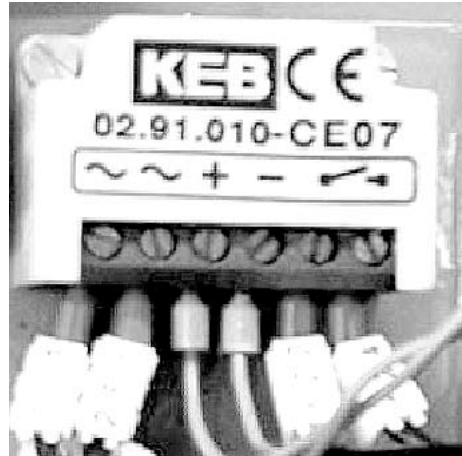

INTERLOCK SWITCH - 51367055

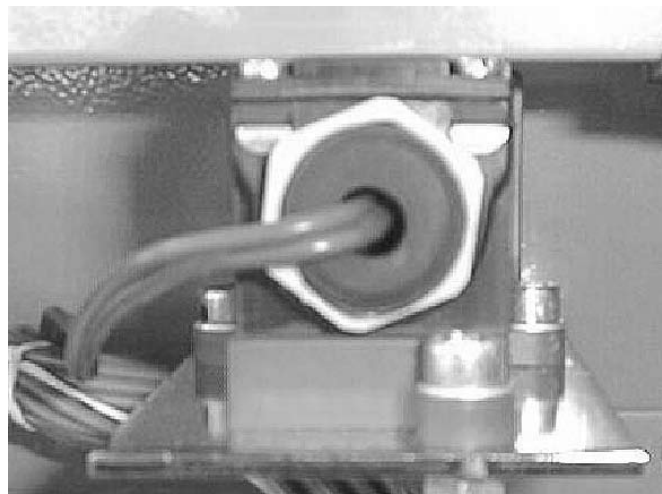

TIMER ASSEMBLY

RELAY
CA2 DN40M7
REF: 0110321

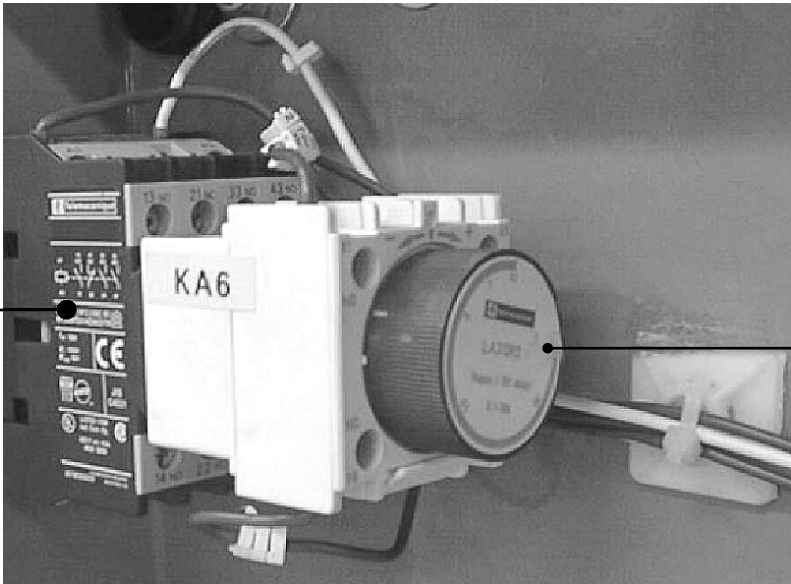

AIR BLAST TIMER
LA3-DR2
REF: 0110212

E-STOP SWITCH ASSEMBLY

E-STOP BUTTON
51367057

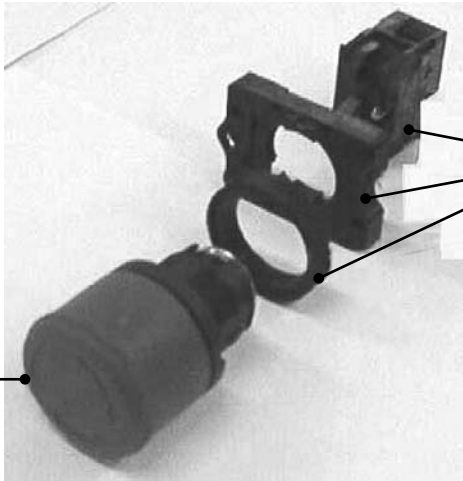

E-STOP CONTACT
51367056

POWER SWITCH ASSEMBLY

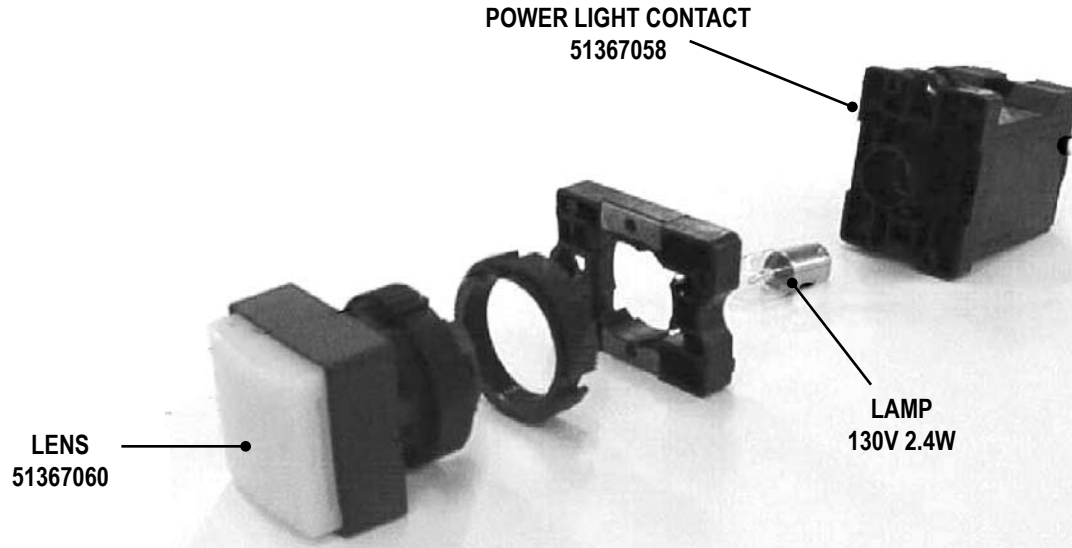

3-POSITION SWITCH ASSEMBLY

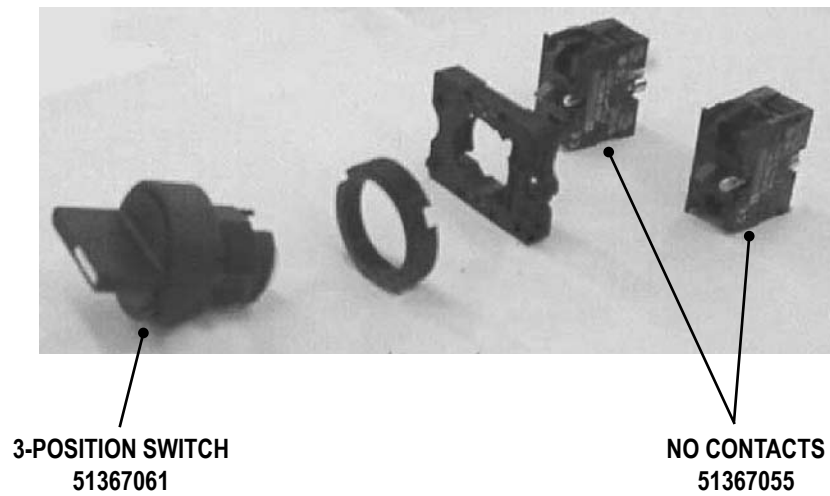

PUSH BUTTON SWITCH ASSEMBLY

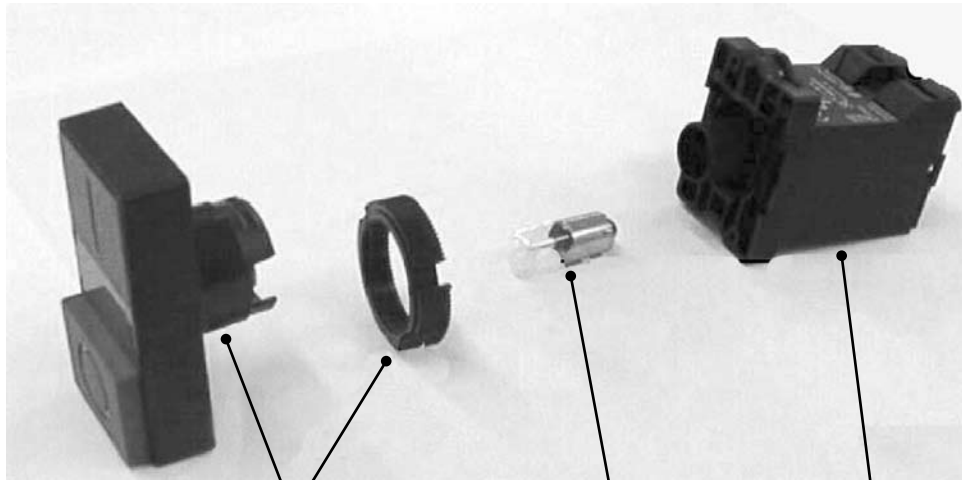

PUSH BUTTON SWITCH
51367063

LAMP
130V 2.4W

SWITCH CONTACT
51367064

POWER SWITCH ASSEMBLY

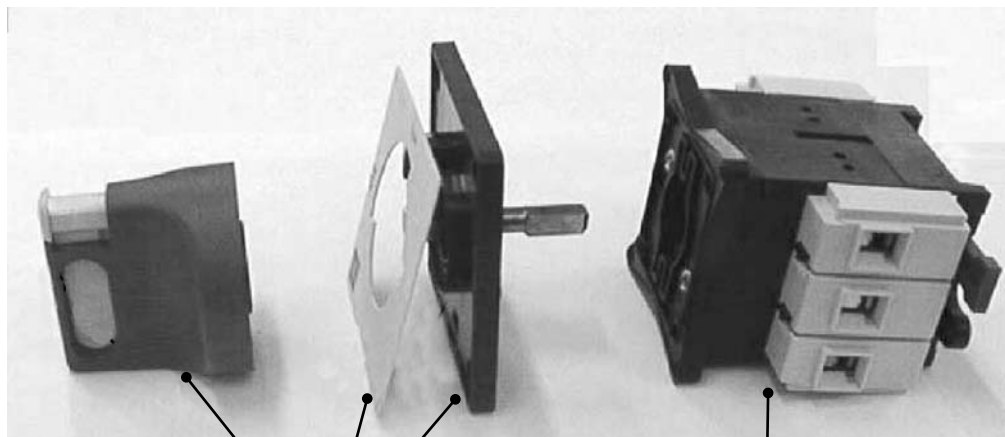

SWITCH
VC1 (VCF1)
REF: 0110536

SWITCH CONTACT
51367065

SEAL TIME POTENTIOMETER ASSEMBLY

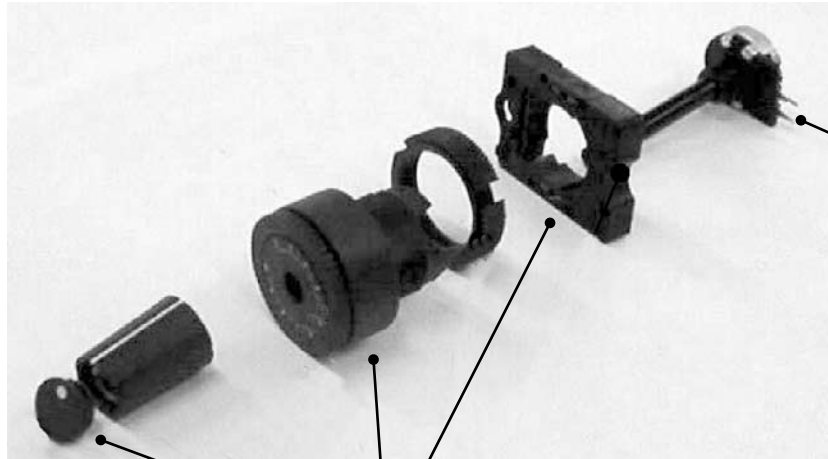

SEAL TIME
POTENTIOMETER
51367067

SEAL TIME HOUSING
51367066

BAG LENGTH SWITCH ASSEMBLY

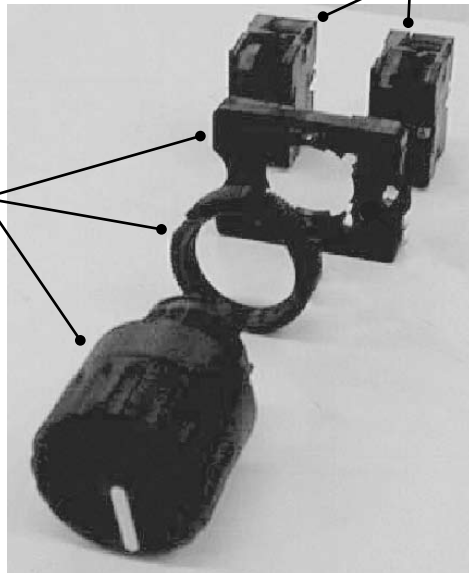

SWITCH CONTACTS
51367062

BAG LENGTH SWITCH
51367068

COUNTER ASSEMBLY

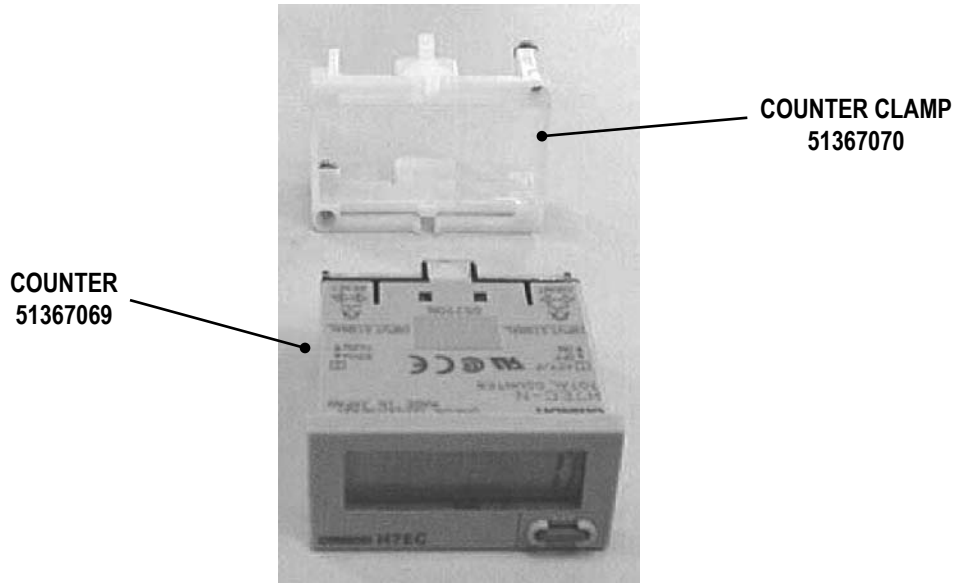

COOLING FAN ASSEMBLY - 0130226



SEALING CONTROL ASSEMBLY



SWITCH
REF: 0110607

KNOB
REF: 0310054

KNOB
REF: 0310054

7 Pneumatic Diagram

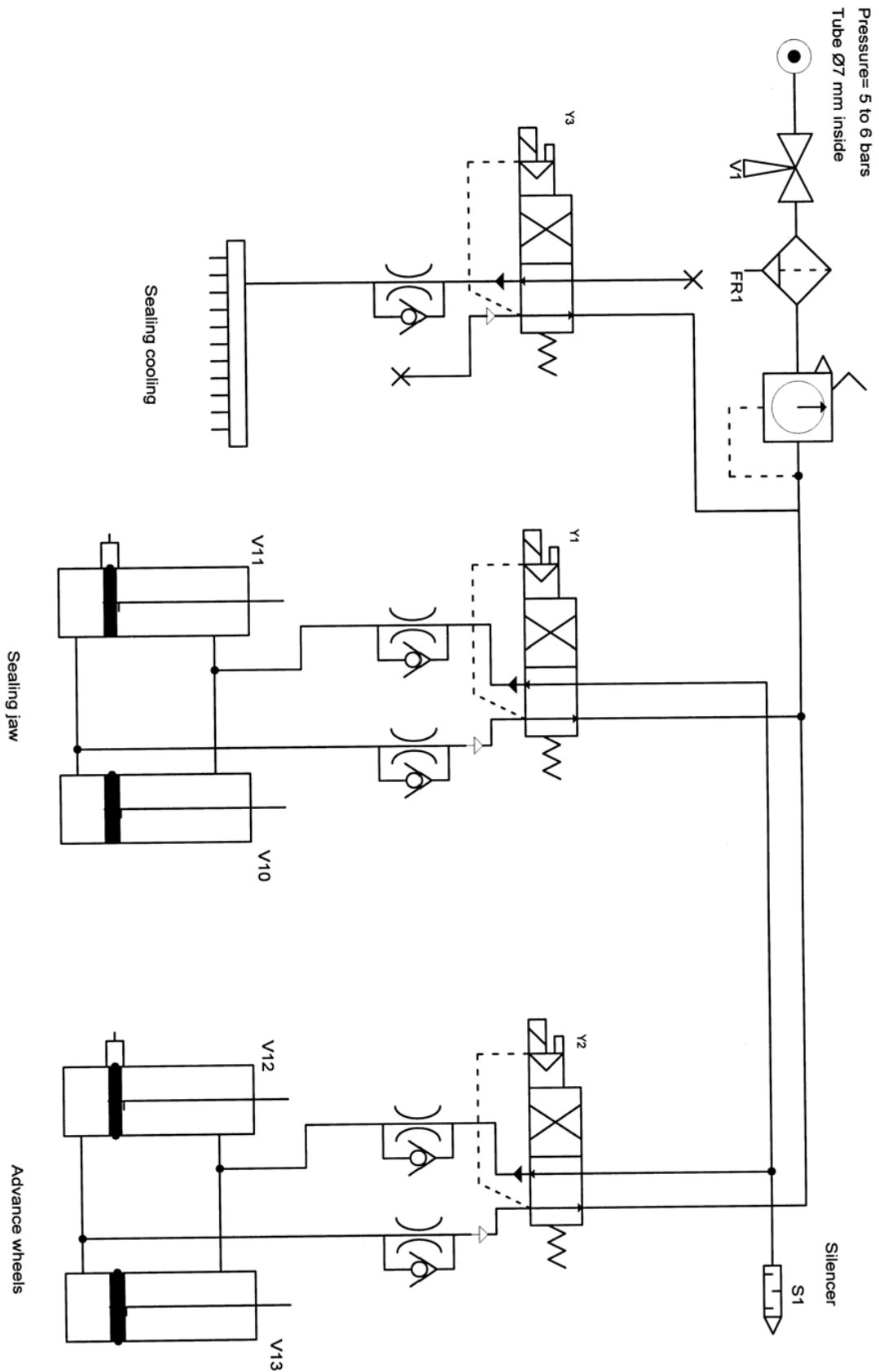

PNEUMATIC NOMENCLATURE

REPRESENTATION	DESIGNATION	REFERENCE CB
V1	Insulation valve	0210146
FR1	Regulator filter	0230045
Y1	Distributor	0210535
	Solenoid valve	0210536
	Flow limitation system	
Y2	Distributor	0210535
	Solenoid valve	0210536
	Flow limitation system	
Y3	Distributor	0210535
	Solenoid valve	0210536
	Flow limitation system	
V10 / V11	Jack jaw dia. 20 stroke 25	0210265
V12 / V13	Jack product passage dia. 16 stroke 10	0210264
D1	Detector diameter 20	0210267
D2	Detector diameter 16	0210266

8 Wiring Diagrams

PNEUMATIC NOMENCLATURE

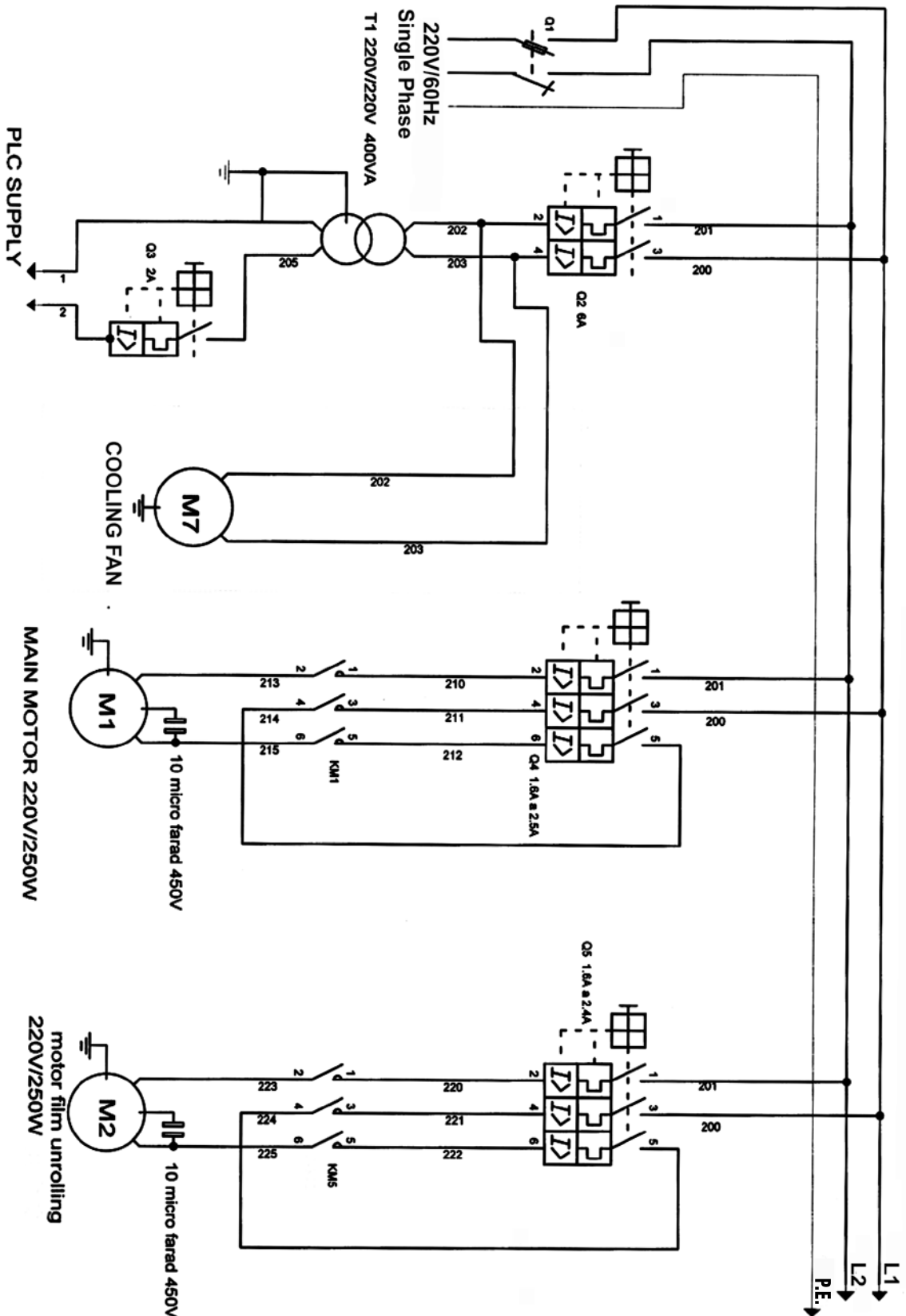

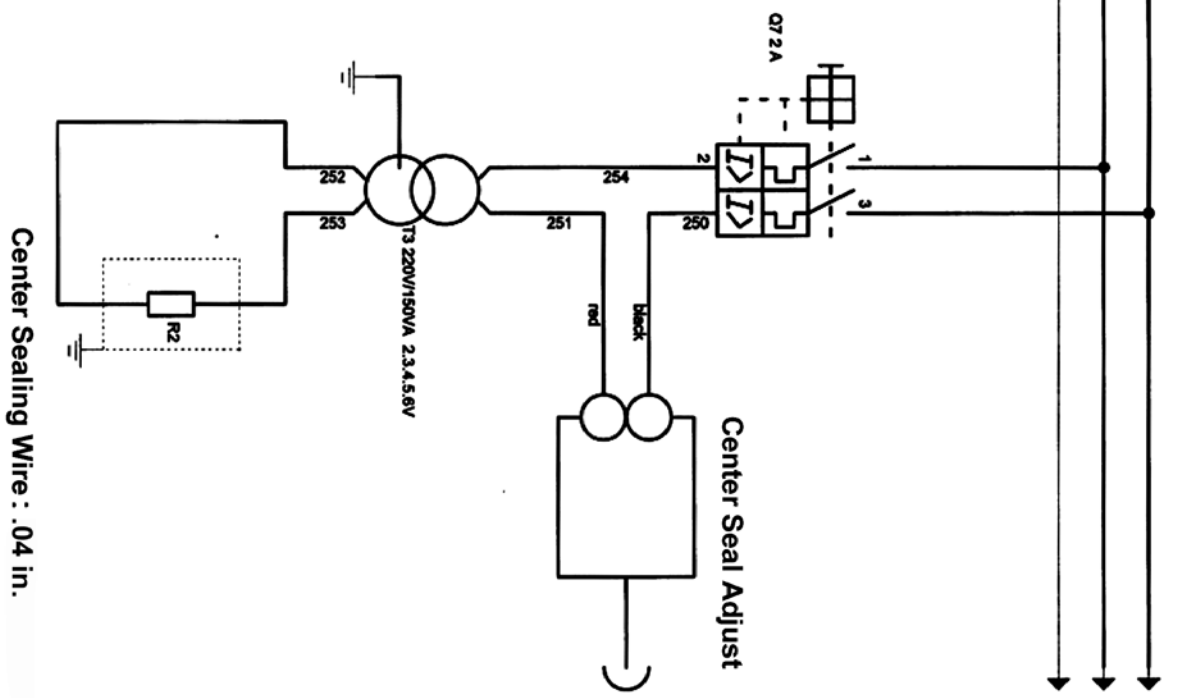
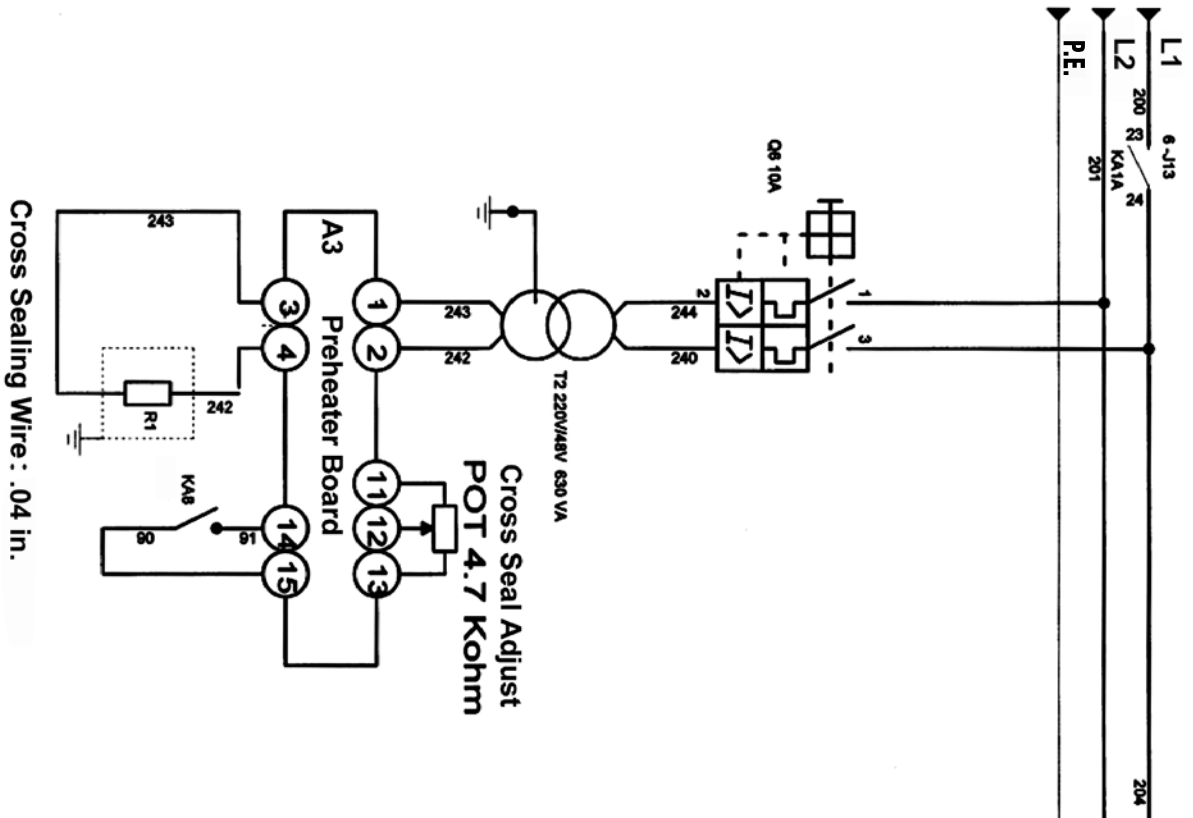

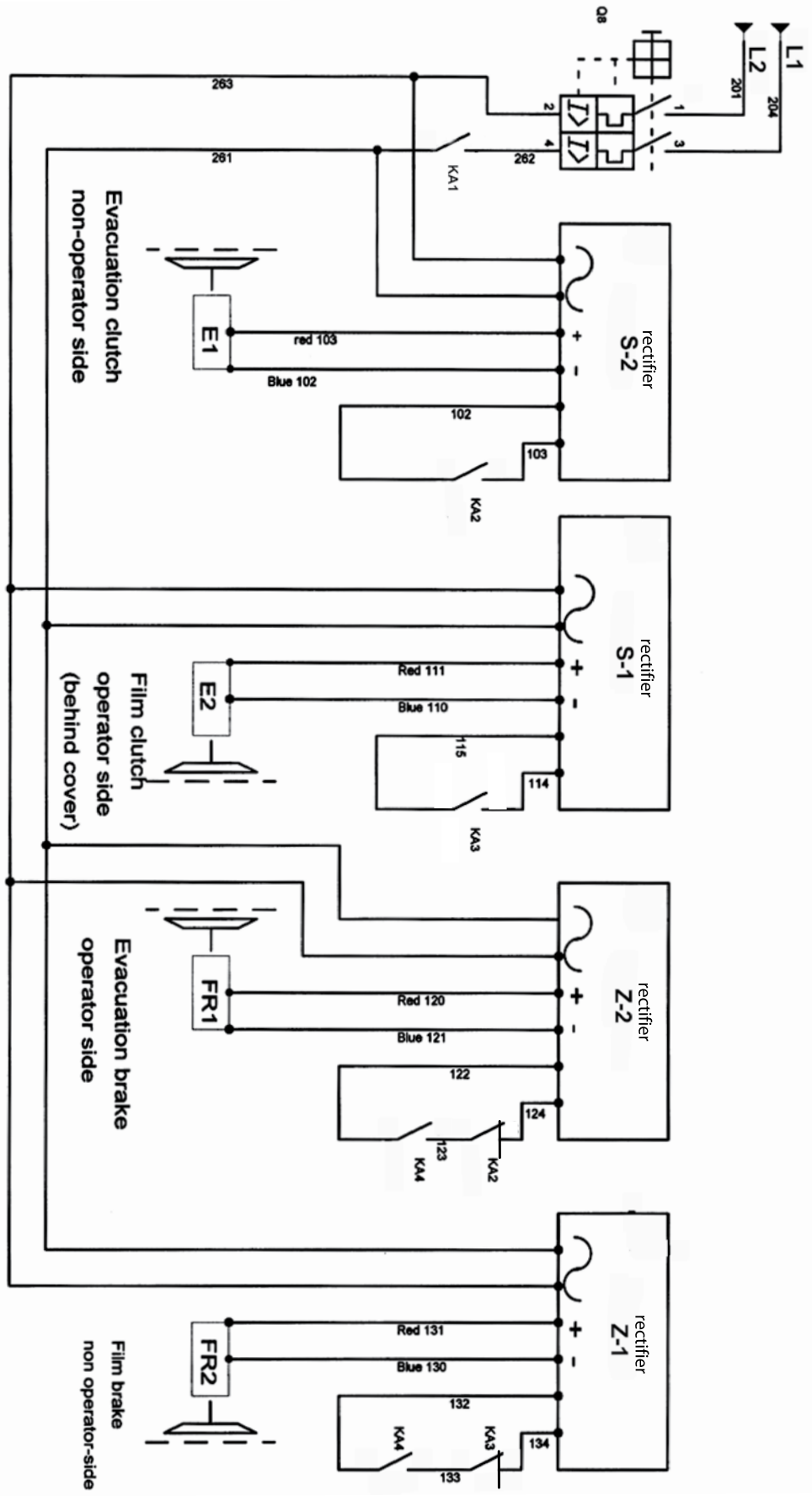

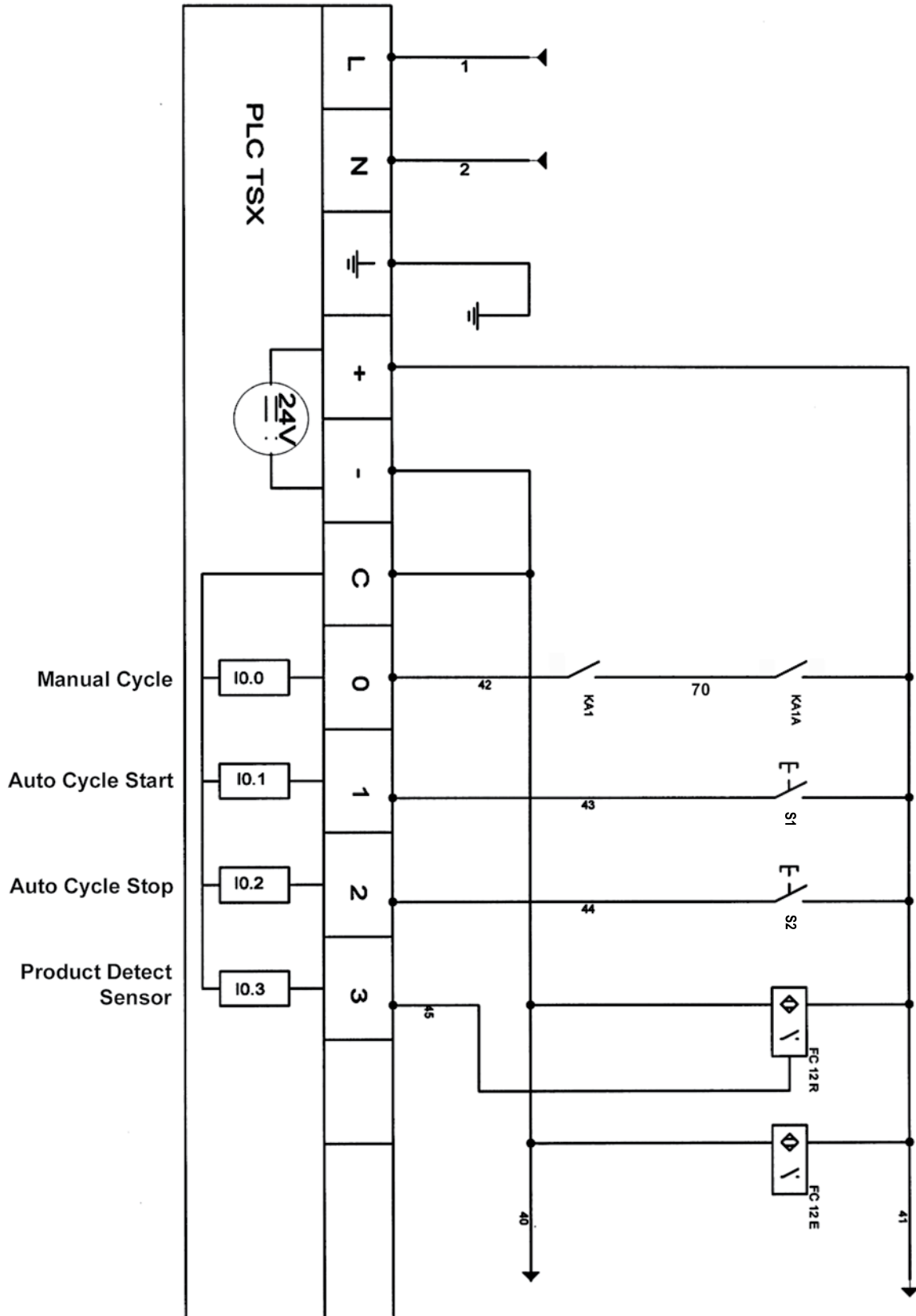

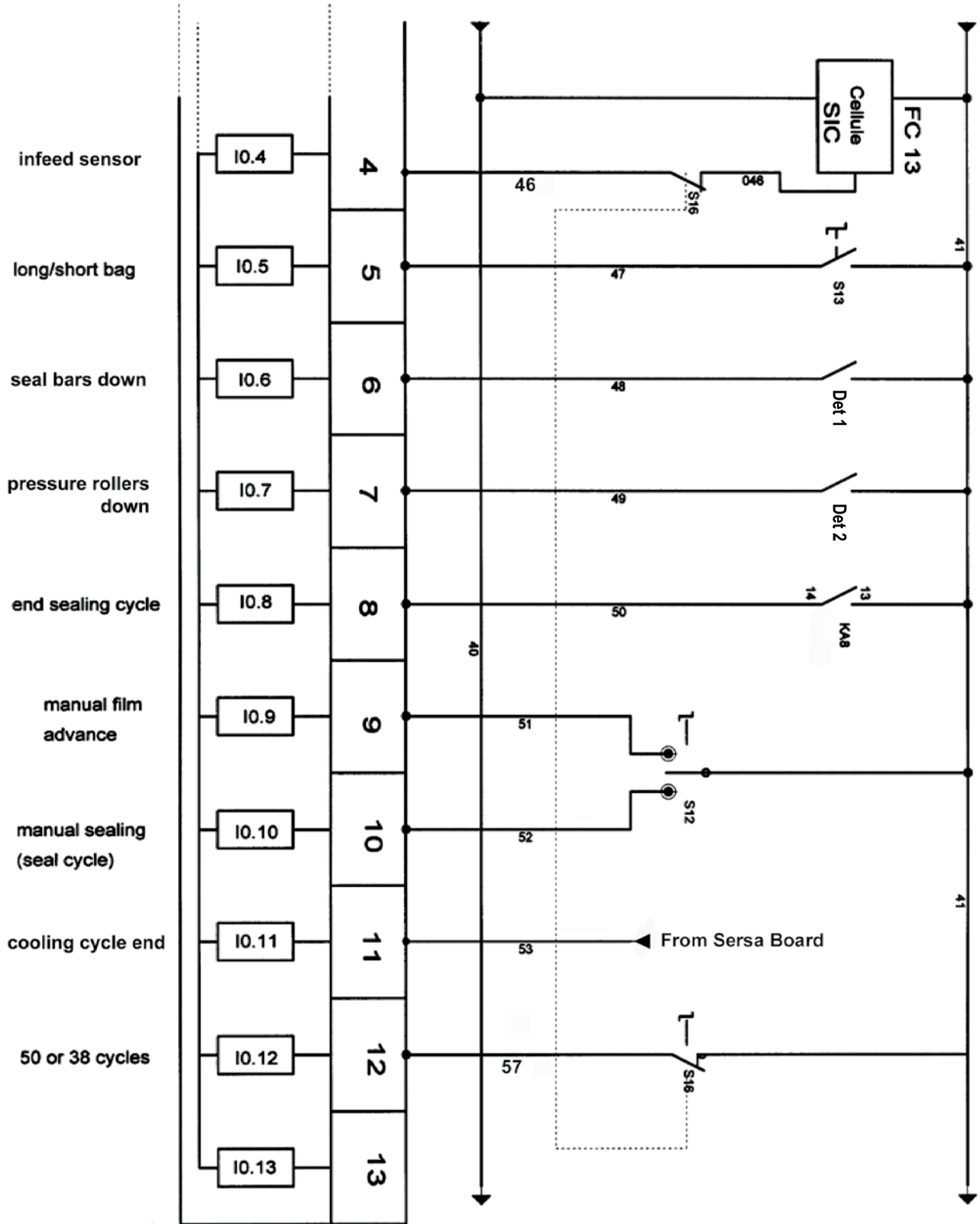

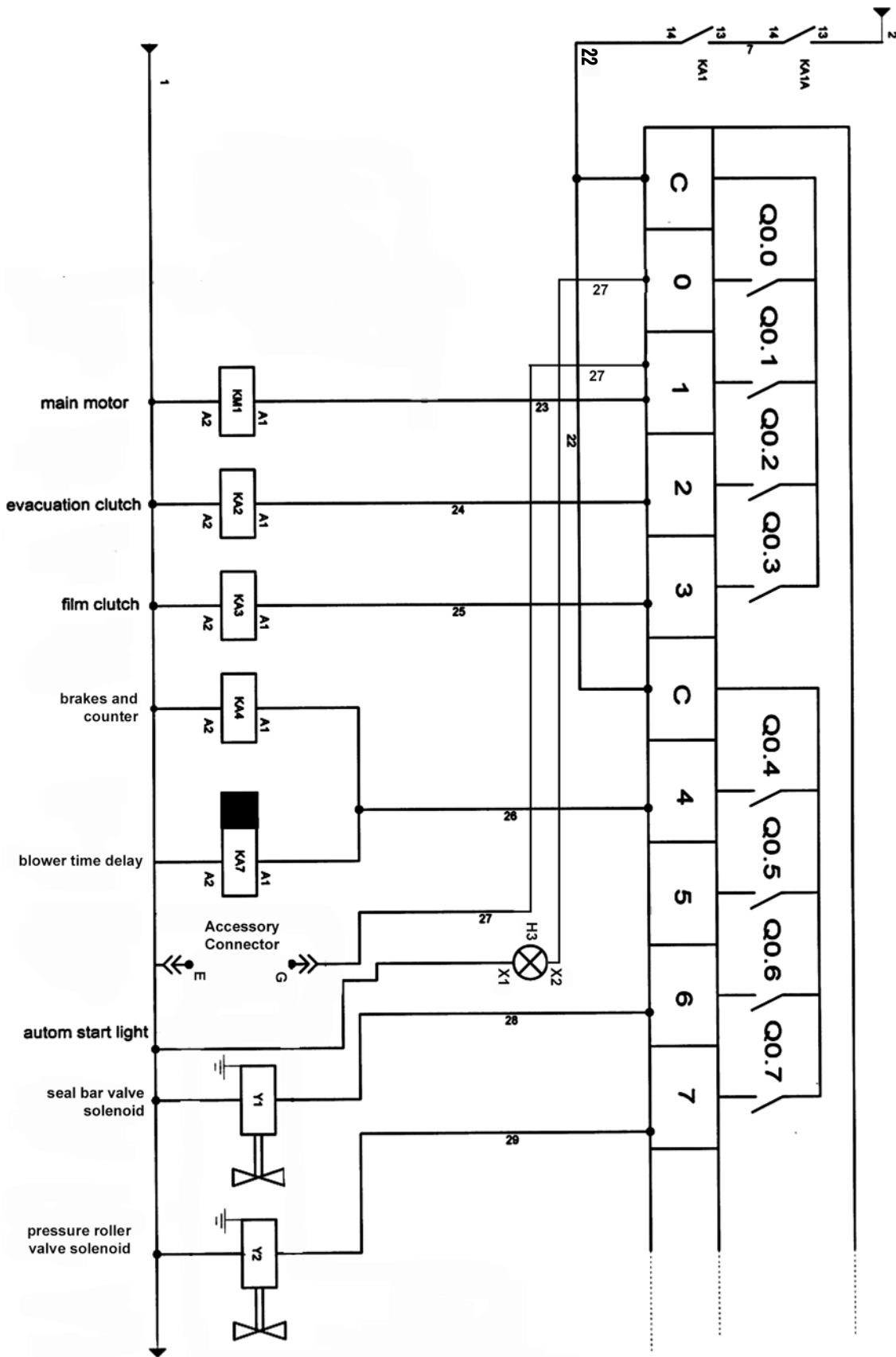

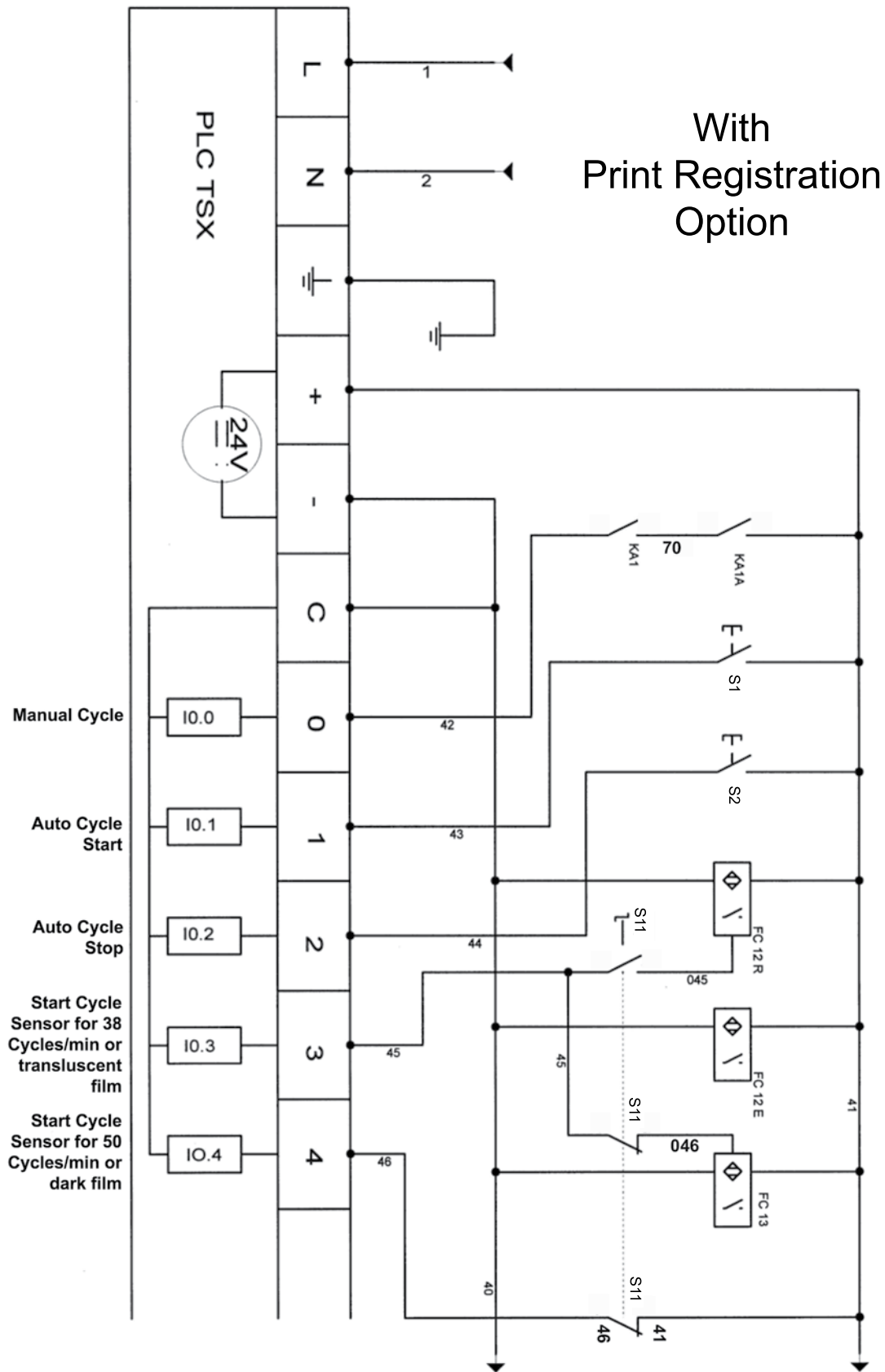

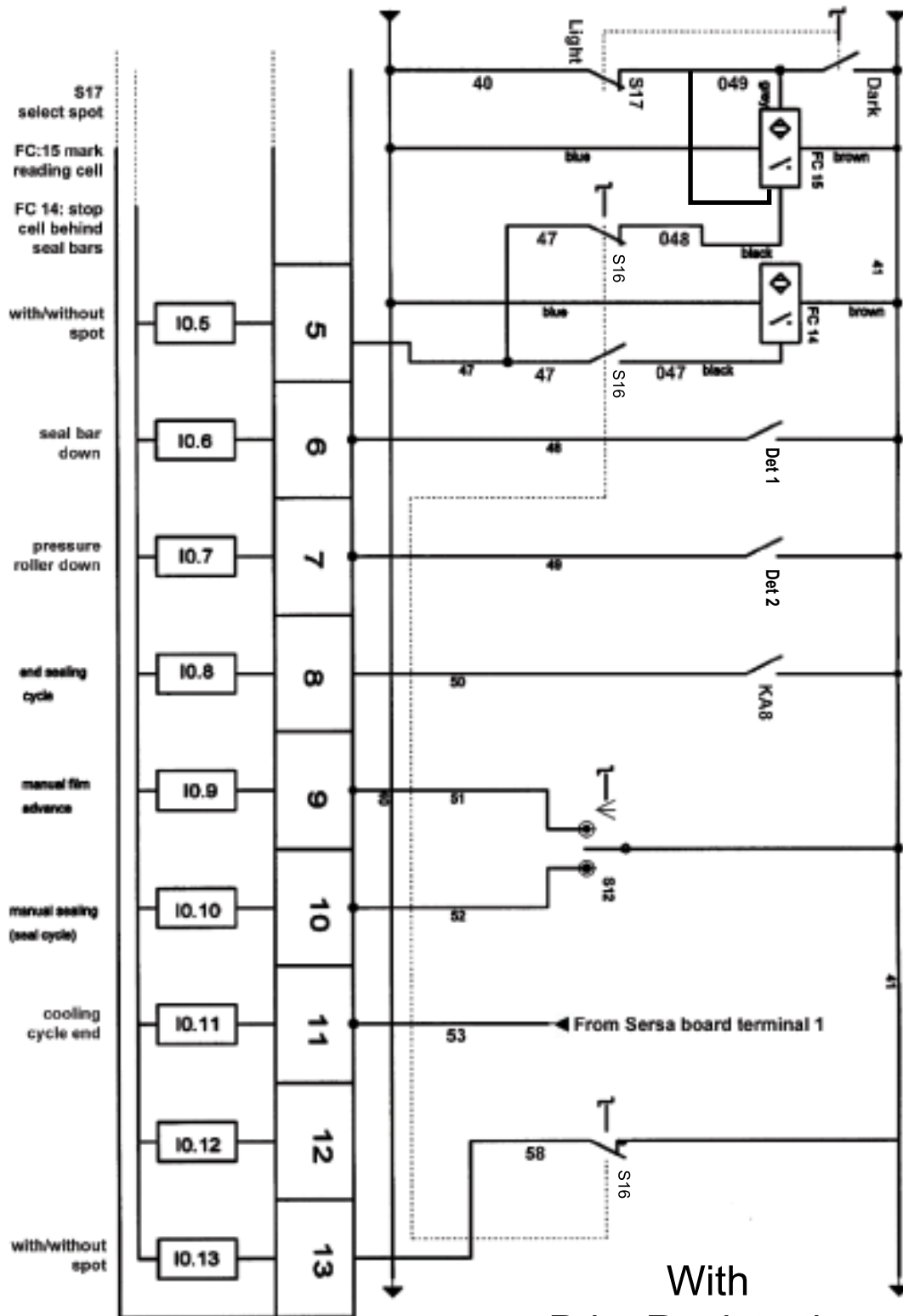

With
Print Registration
Option

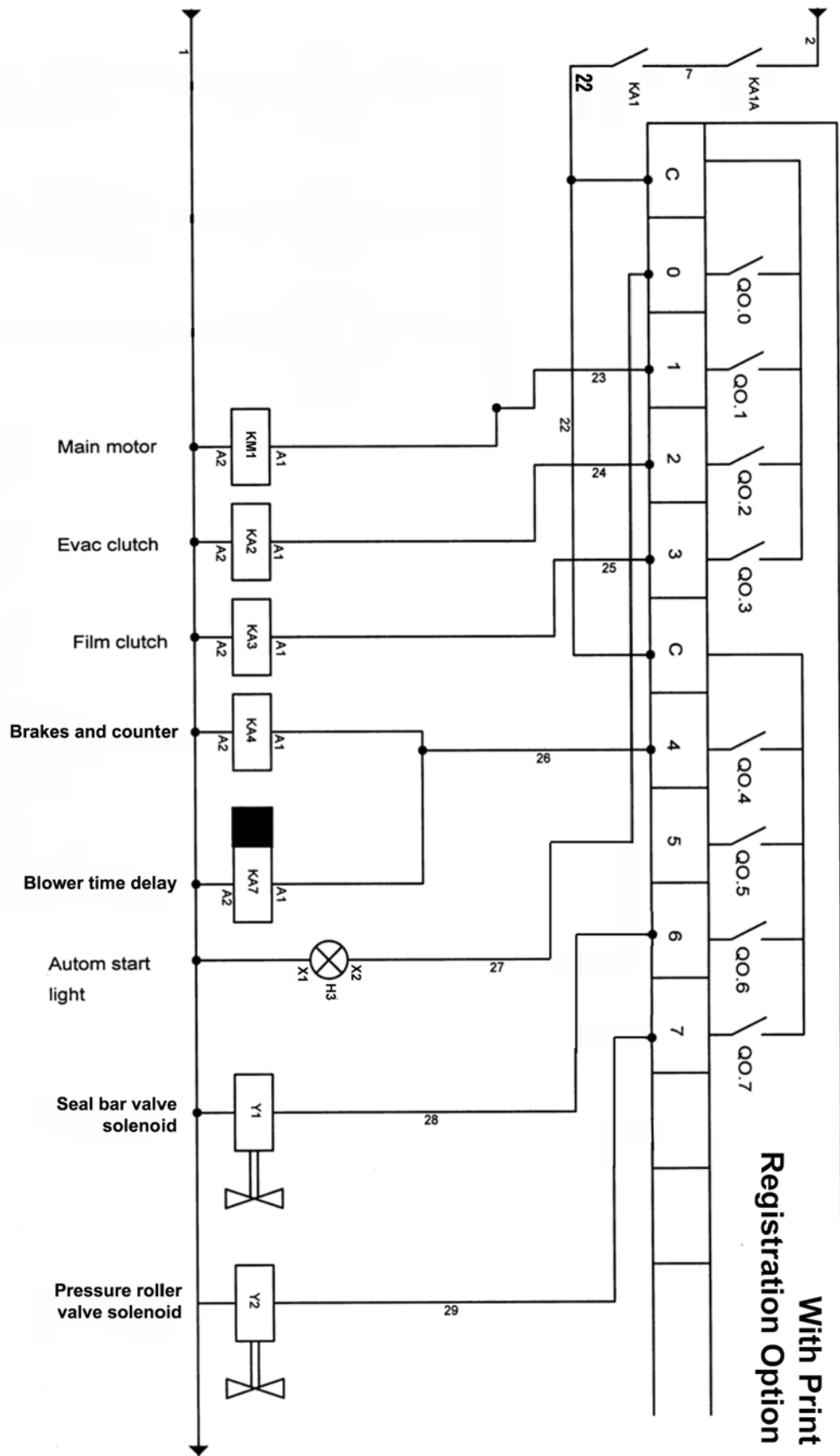

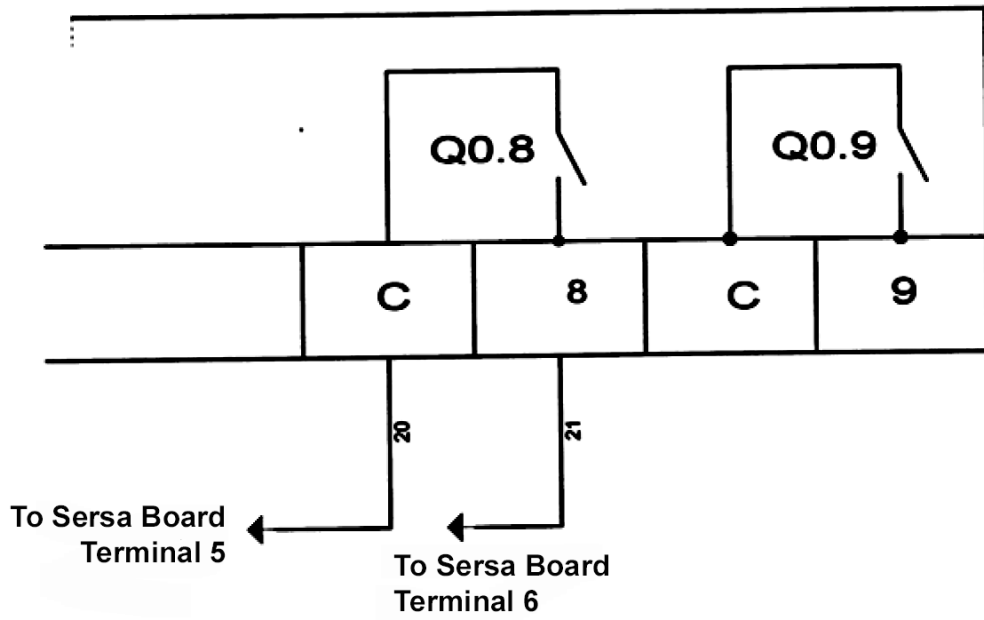

SERSA CONTROL BOARD

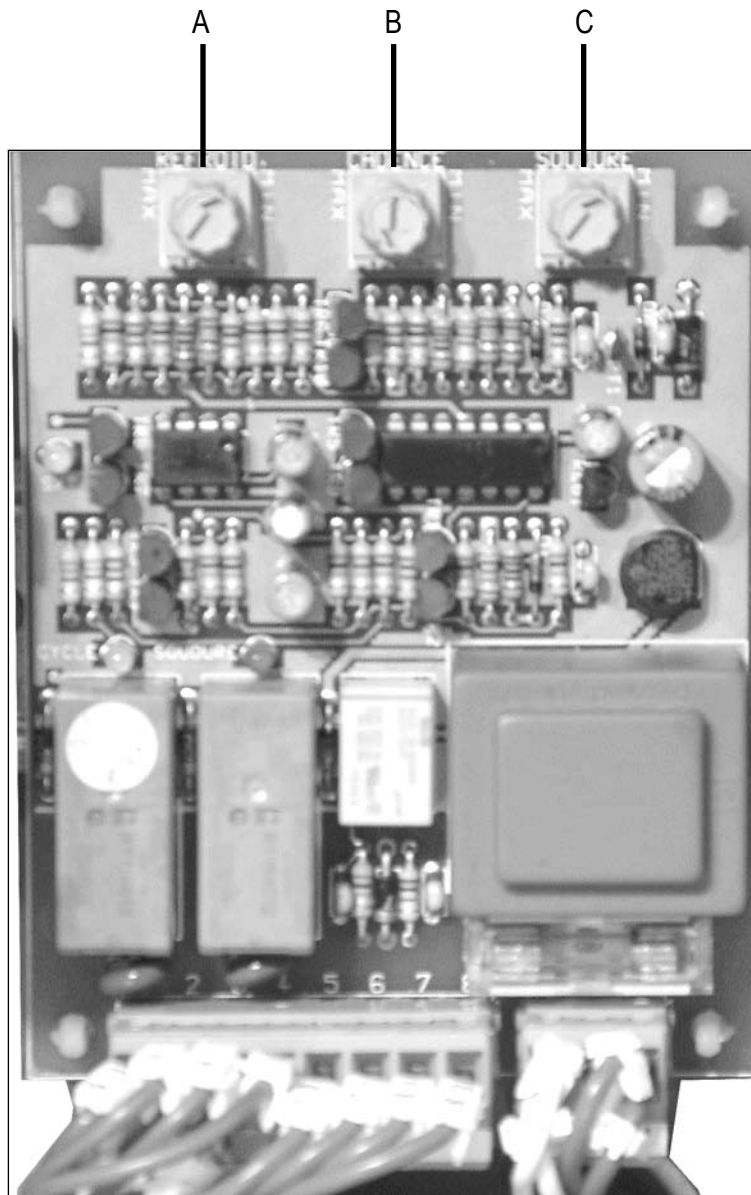

A = COOLING: Factory set to FULL MINIMUM.

B = IMPULSE TIME: Average setting is at 6 o'clock position. This setting can be increased or decreased based on film type. If there is excessive fuming, increase the impulse time by turning the potentiometer clockwise. If the seal is weak, decrease the impulse time by turning the potentiometer counterclockwise. Adjustments should be made in "one-hour" increments.

C = SEALING: Factory set to FULL MINIMUM.

Thiele
Technologies
A Barry-Wehmler Company

Streamfeeder

103 Osborne Road • Minneapolis, MN 55432-3131 USA
TEL: 763.502.0000 • FAX: 763.502.0100
E-MAIL: service@streamfeeder.com
WEB: www.streamfeeder.com

